

Eleiko Powerlifting Squat Stand/Bench Combo

Art.no. 3085245

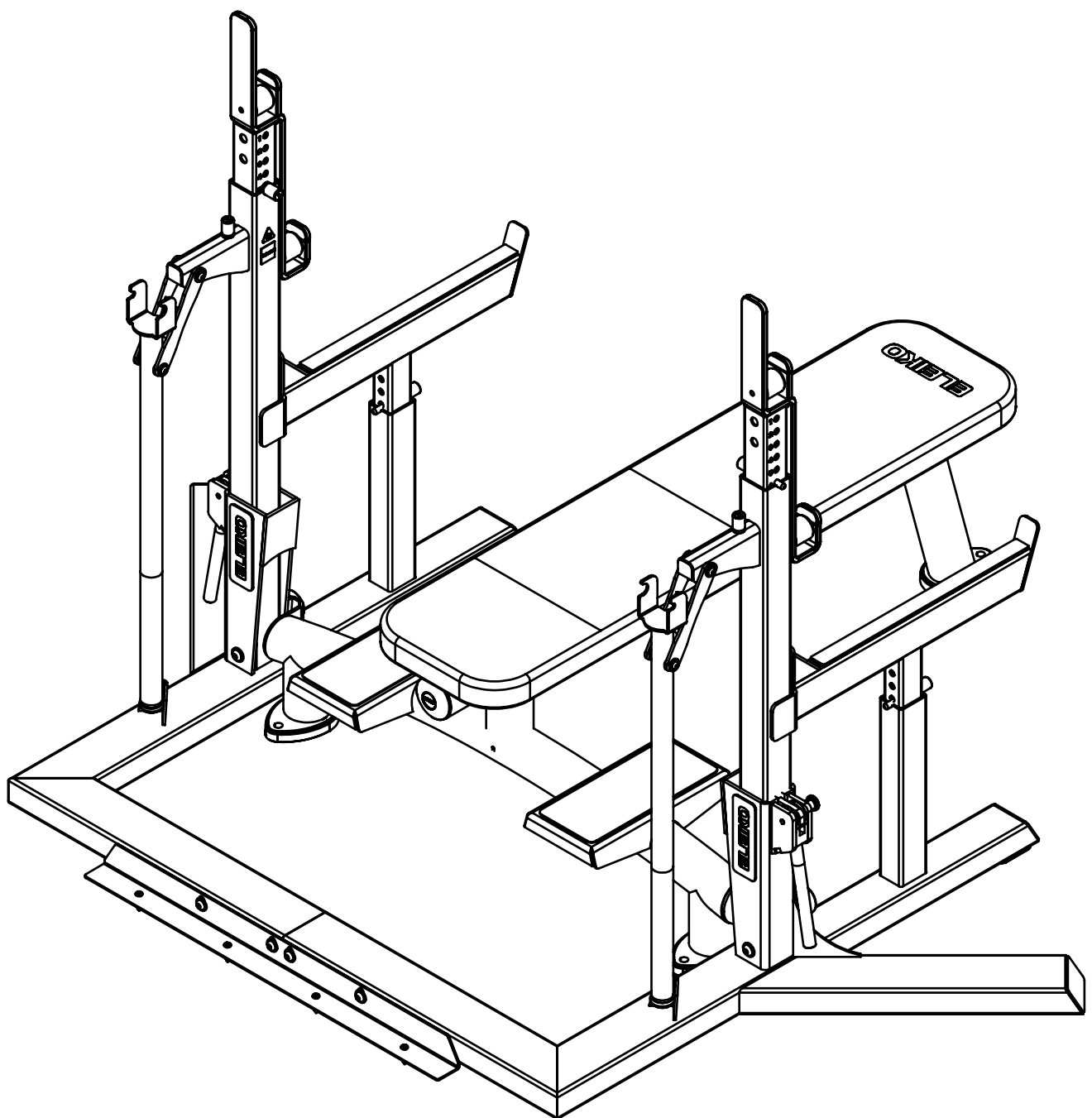

ELEIKO

READ BEFORE INSTALLATION AND USE

CAUTION

The equipment must be installed and used in a place whose access and supervision are specifically controlled by the owner.

Be sure to install the equipment on a stable base and properly level the equipment. ELEIKO recommends that all equipment is secured to floor and installed by a licensed contractor or an ELEIKO-installer.

SAFETY INSTRUCTIONS

It is the responsibility of the purchaser of ELEIKO products to instruct all users and supervising personnel on proper usage of the equipment.

1. All included warnings (labels) and instructions **MUST** be read before the use of any ELEIKO-equipment. Use each equipment as it is intended for.
2. A user **MUST** get a medical examination and proper instructions before the use of any ELEIKO-equipment.
3. **DO NOT** let anyone, under any circumstances, use equipment that appears to be damaged. Do not try to repair any equipment before consulting an ELEIKO technician.
4. **DO NOT** replace the components of ELEIKO-equipment with other none ELEIKO-equipment (magnetic safety pin, frames, bars), do not improvise. If there are any doubts consult an ELEIKO representative prior to any intervention.
5. **DO NOT** overload the equipment and **DO NOT** try to exceed personal strength levels.
6. Children under the age of 14 must be supervised by an adult.
7. **DO NOT** remove any safety labels from the ELEIKO-equipment. ELEIKO is not responsible if a label is removed. Replace damaged labels immediately.
8. Eleiko package for products can be made of wood, be aware of splinters, **MUST** use gloves and proper work wear.
9. Eleiko package material could be a risk when handling, be aware of crushing, **MUST** use work wear including gloves and hard shoes.
10. Eleiko products and packing material is heavy, **MUST** use proper lifting technique, work wear and hard shoes.

PREVENTITIVE MAINTENANCE & INSPECTIONS

DAILY:

Cleaning of upholstery.

REGULARLY:

Clean the surfaces on frames and tubes from dust and dirt.

Check that all bolts between parts, walls, floors are properly tightened, according to recommendations. Check equipment for sharp edges, replace parts with sharp edges.

WARRANTY

All products manufactured by ELEIKO are warranted to the original purchaser to be free from defects in workmanship and / or materials under normal use or service as follows:

10 years on welds on structural frame (NOT on moving parts)

1 year on upholstery

Normal wear and tear does not fall under the warranty of 10 years.

ADDITIONAL INFORMATION

This equipment is for indoor use only.

The logo for ELEIKO, consisting of the word "ELEIKO" in a bold, uppercase, sans-serif font.

PRODUCT SPECIFICATIONS

Eleiko Powerlifting Squat Stand/Bench Combo is used for IPF powerlifting competitions and training. Bench press and squat are the two exercises it is made for.

To change height of uprights and safety arms, make sure no person is under or close to the bar, lift the upright or safety arm up and place the pin in correct hole, make sure to insert the pin properly. Lower the uprights or safety arms slowly until pin is in contact.

| | |
|------------------------|--------------------------------------|
| Product weight | 115 kg 253 lbs |
| Max user weight | 300 kg 661 lbs |
| Max training weight | 750 kg 1650 lbs |
| Dimensions (L x W x H) | 2010x1650x1875 mm 80" x 65" x 74" |

FOOTPRINT AREA

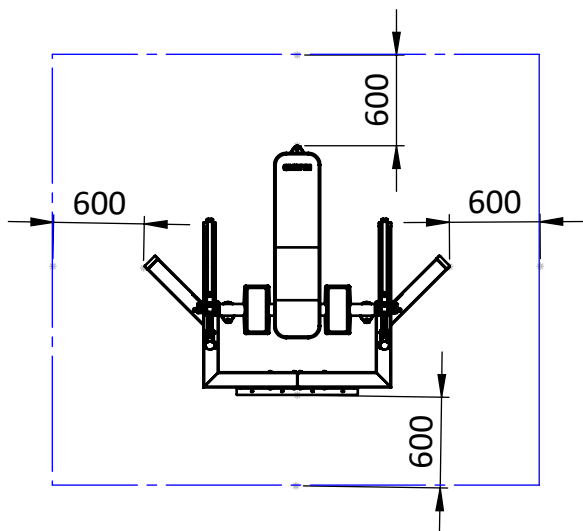

Add sufficient clearance, not less than 0,6 m, on all sides. Taking in account the accessibility to remove and replace bar and weights

CONTENTS

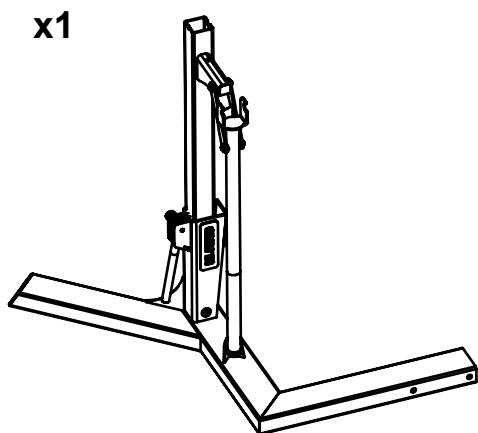

Right side base
3085120A56

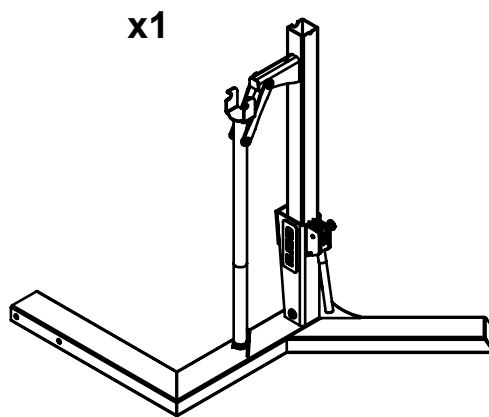

Left side base
3085120A55

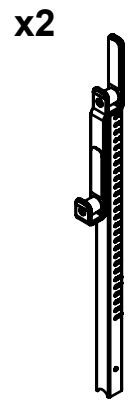

Barbell support
3085221

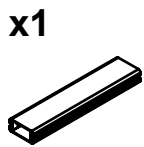

Assembly section
3085120A31

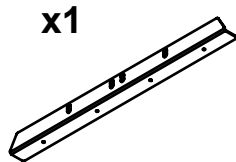

Sheet metal
3085120p162

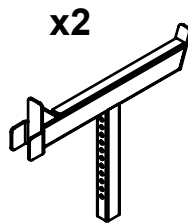

Safety arm
3085120A07

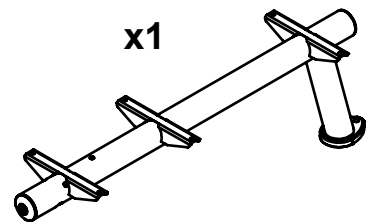

Base for upholstery
3085120A57

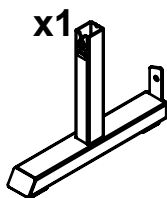

Left side safety base
3085120A27

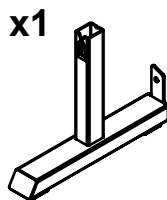

Right side safety base
3085120A34

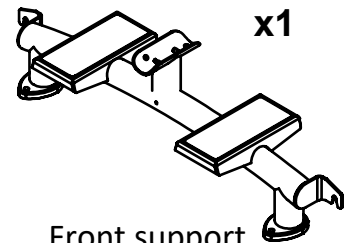

Front support
3085120A258

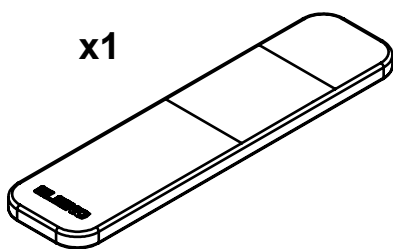

Upholstry
2000839

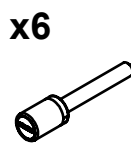

Insert pin Magnetic
2001152



Stainless steel knob D=49,5, M12
2001539



Screw M8x16
2000747-L16

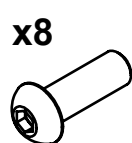

Screw M10x30
2000675-L30



Screw M12x25
2000743-L25



Washer
2000719

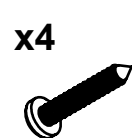

RXS 5,5x32
2000855-L32

REQUIRED TOOLS



Hex key
5 mm



Hex key
6 mm

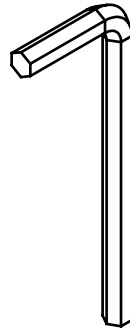

Hex key
8 mm



Screw driver
Philips

Would **not** recommend electric power tools for assembly.

GENERAL

The table below is general torque to use for different threads. Use these torques, if nothing else is set. Below numbers are for screw/nut of quality 8.8.

| THREAD | TORQUE (Nm / ftlb) Quality 8.8 |
|--------|-----------------------------------|
| M8 | 24 / 17,7 |
| M10 | 47 / 34,7 |
| M12 | 81 / 59,7 |

ASSEMBLY INSTRUCTIONS

1.

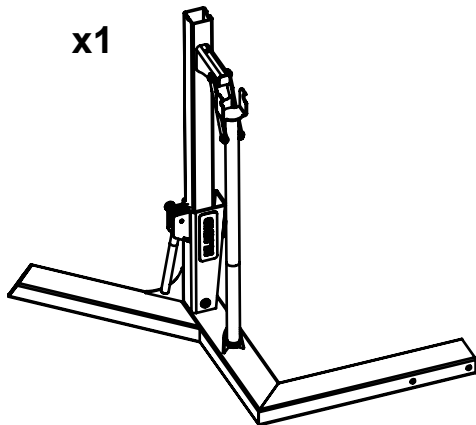

x1

Right side base
3085120A56

x1

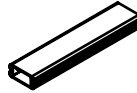

Assembly section
3085120A31

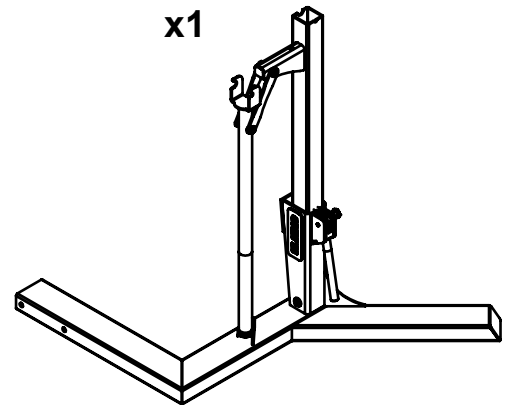

x1

Left side base
3085120A55

x8

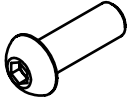

Screw M10x30
2000675-L30

x8



Washer
2000719

x1

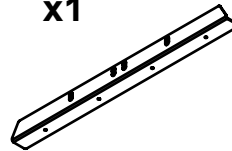

Sheet metal
3085120p162



Do not tighten the screws,
Loose fit

2.

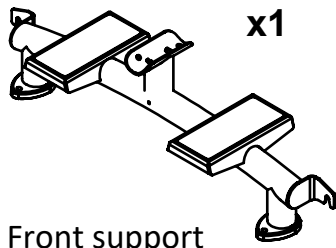

Front support
3085120A258

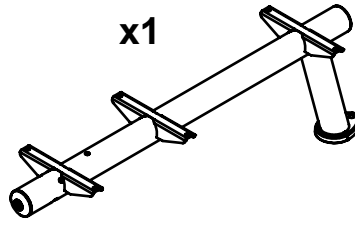

Base for upholstery
3085120A57

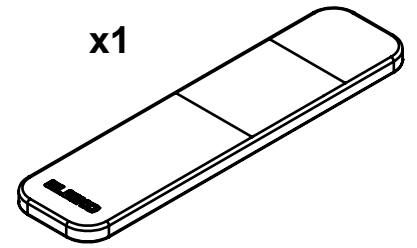

Upholstry
2000839

x6



Screw M8x16
2000747-L16

x3

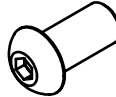

Screw M12x25
2000743-L25

Use your fingers to fit the M8
Screws and no power tool to tighten
Make sure to level the padding with flooring.

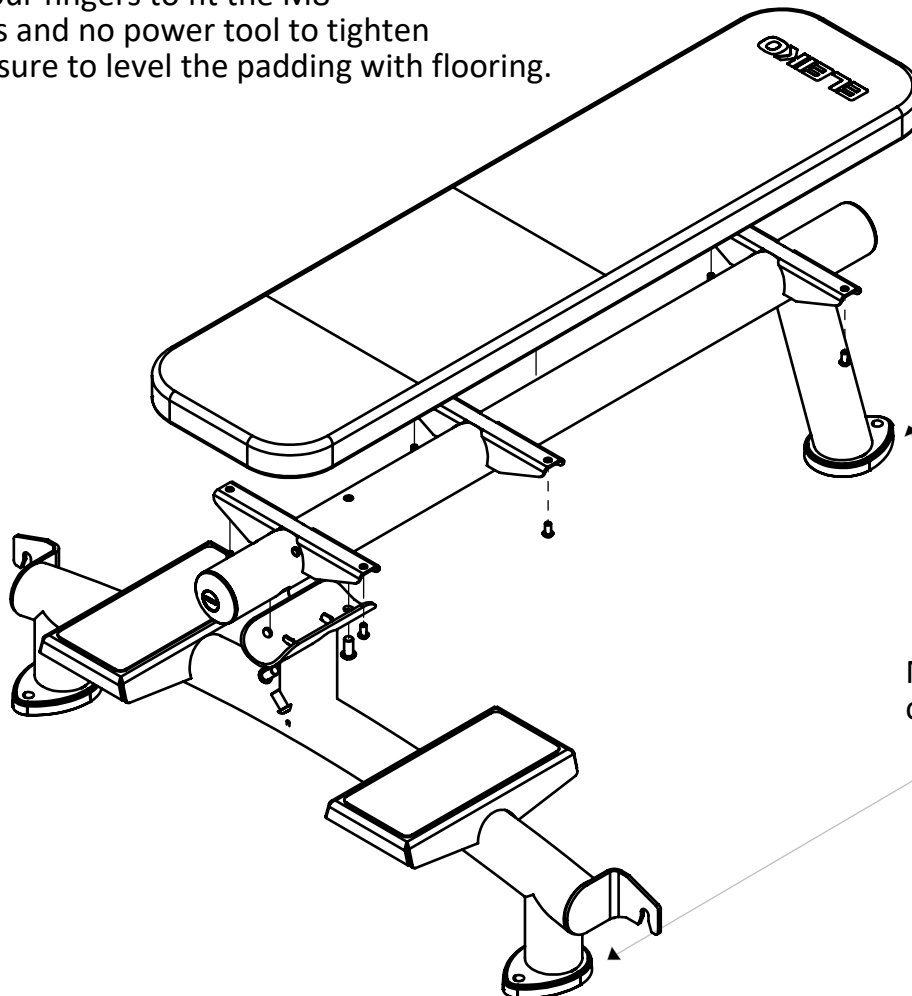

Make sure feet are in
opposite direction!

3.

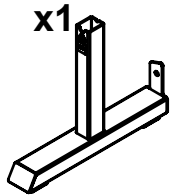
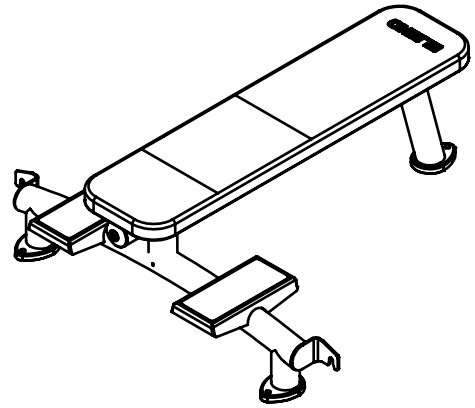
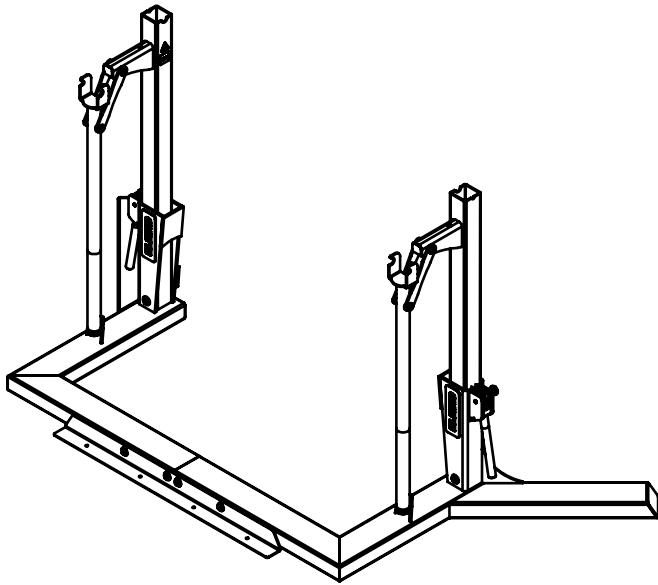

Left side safety base
3085120A27

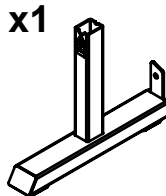

Right side safety base
3085120A34



x2

Eleiko Handle D=50 M12 Chromed
3085316

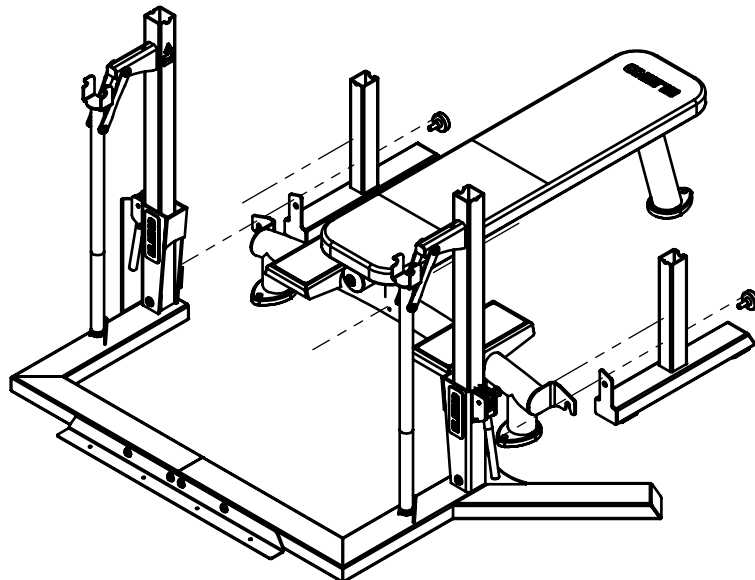

4.

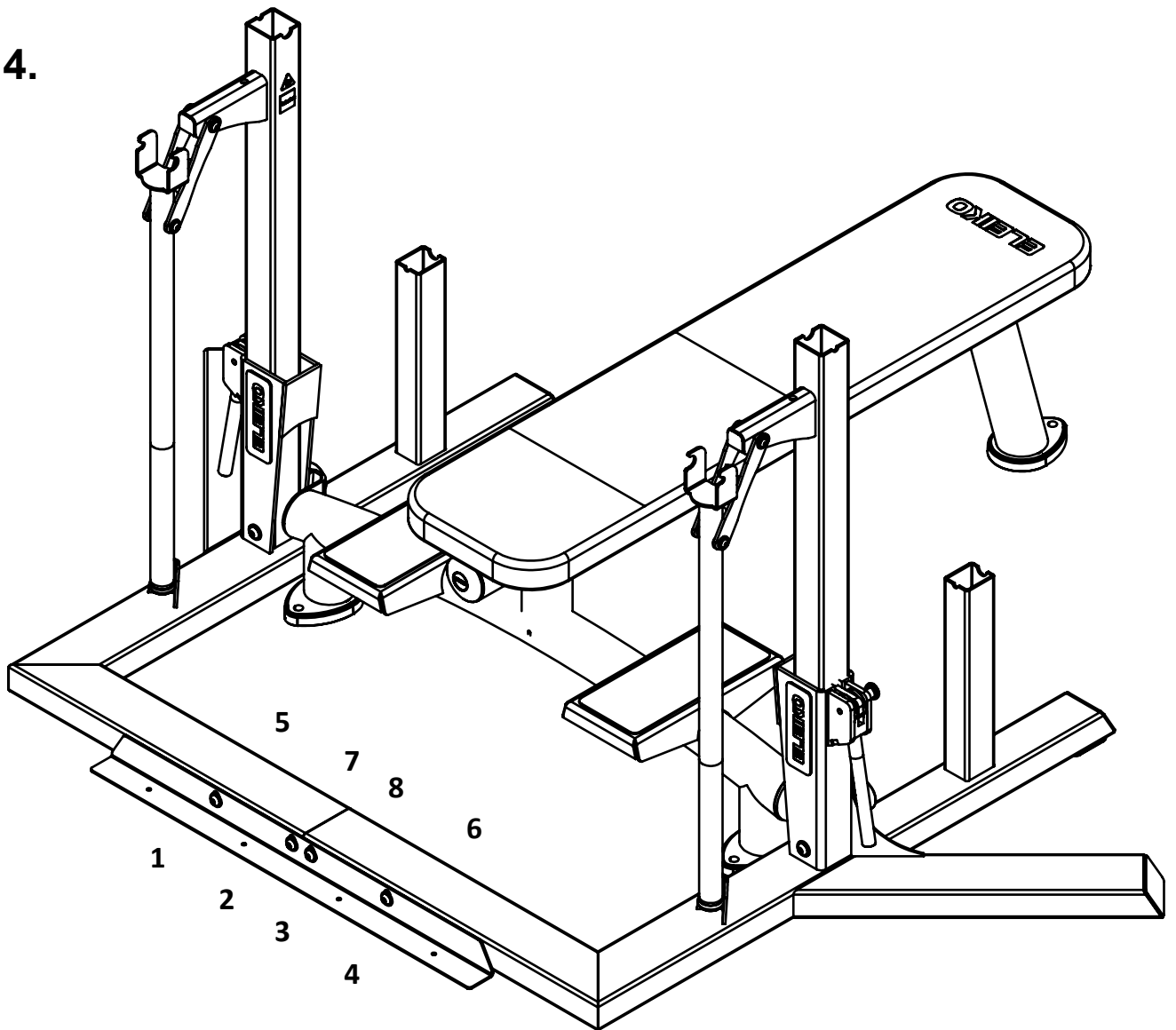

Tighten the screws in order 1-8

5.

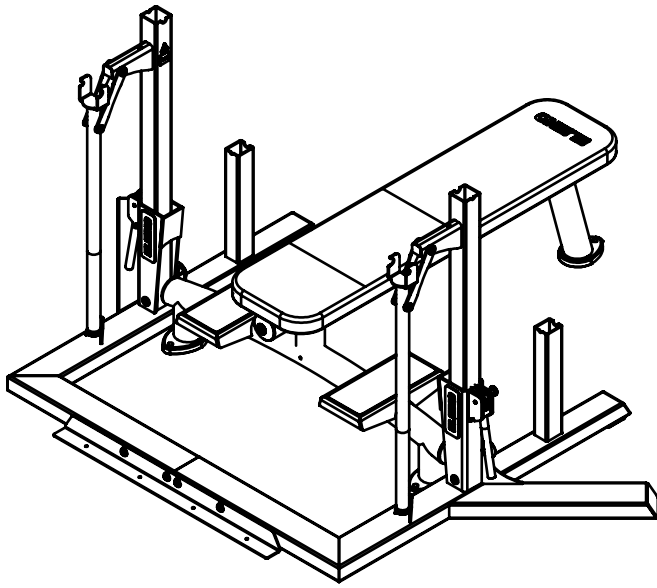

x2



Barbell support
3085221

x2

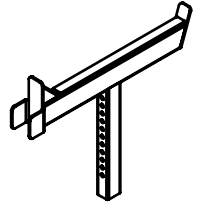

Safety arm
3085120A07

x6



Insert pin Magnetic
2001152

x4



RXS 5,5x32
2000855-L32

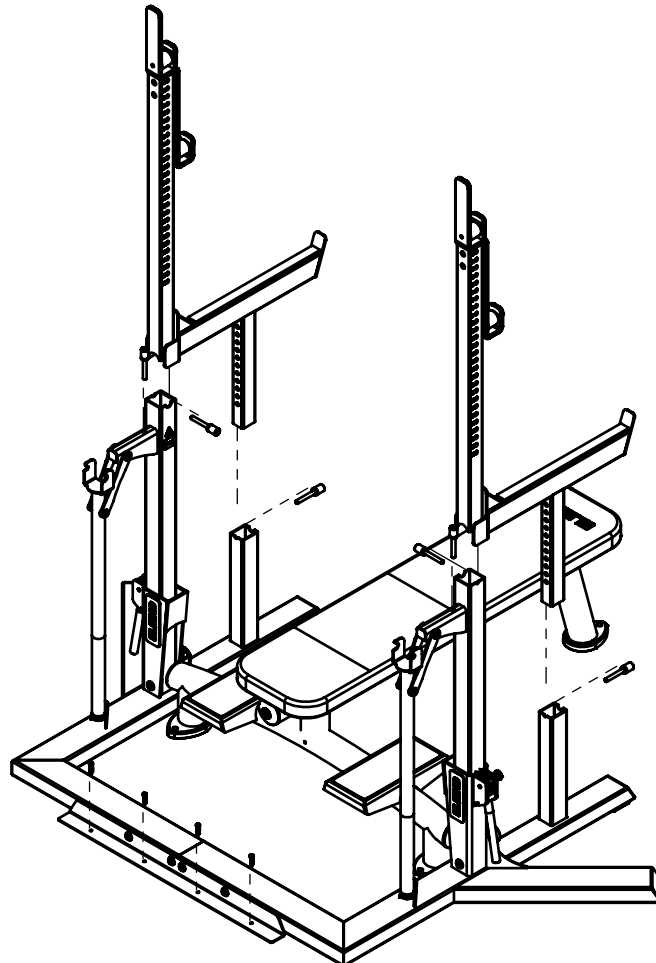

ELEIKO

6.

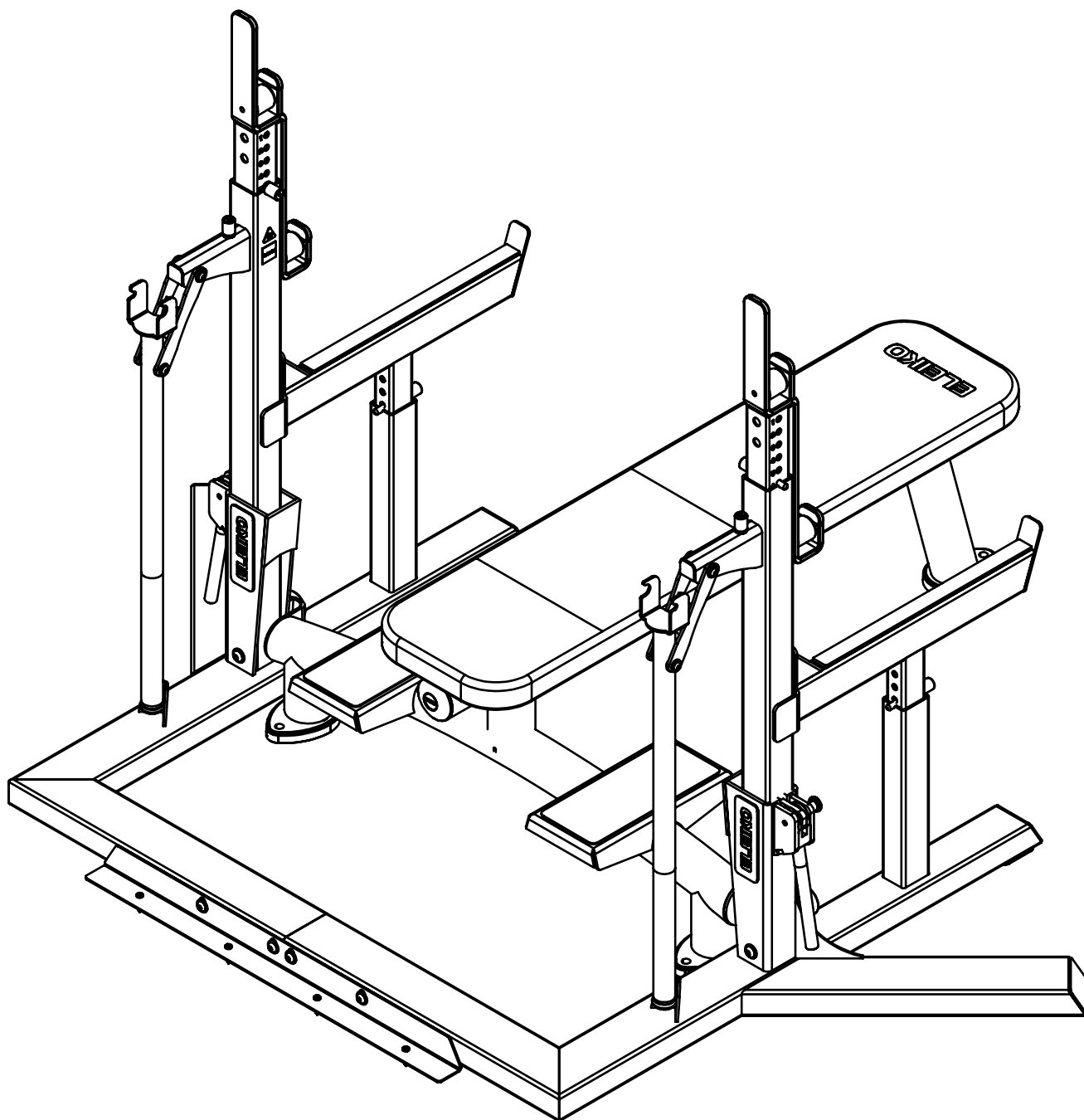

Tighten all screws properly
For safe use, be certain pins are properly inserted
before load bar on bench.

ELEIKO

- 6.** Eleiko Powerlifting Squat Stand/Bench Combo is used for IPF powerlifting competitions and training. Bench press and squat are the two exercises it is intended for.

User Manual

Set up according to below:

Bench press

-Set safety arms 3 or higher

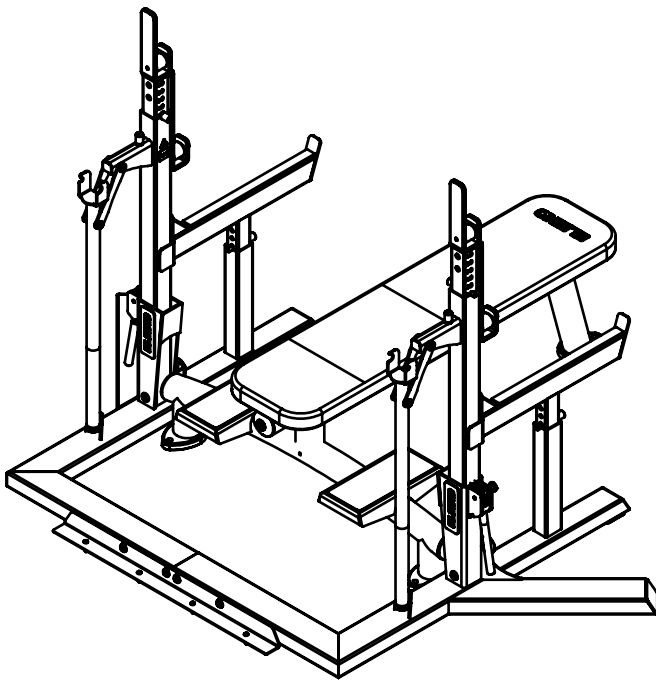

Squat

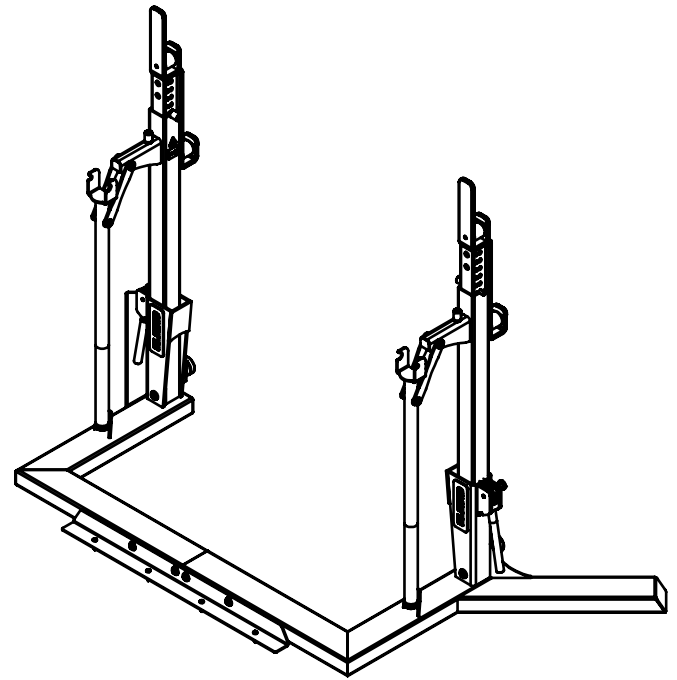

ELEIKO

RAISE THE BAR

Eleiko Group AB | Klastorpsvägen 18 | SE-302 62 HALMSTAD | Sweden
E-mail: info@eleiko.com | Phone: +46 35 17 70 70

www.eleiko.com