

# ELEIKO PRESTERA STORAGE LEG

Art.no. BD-1-528, BD-1-529

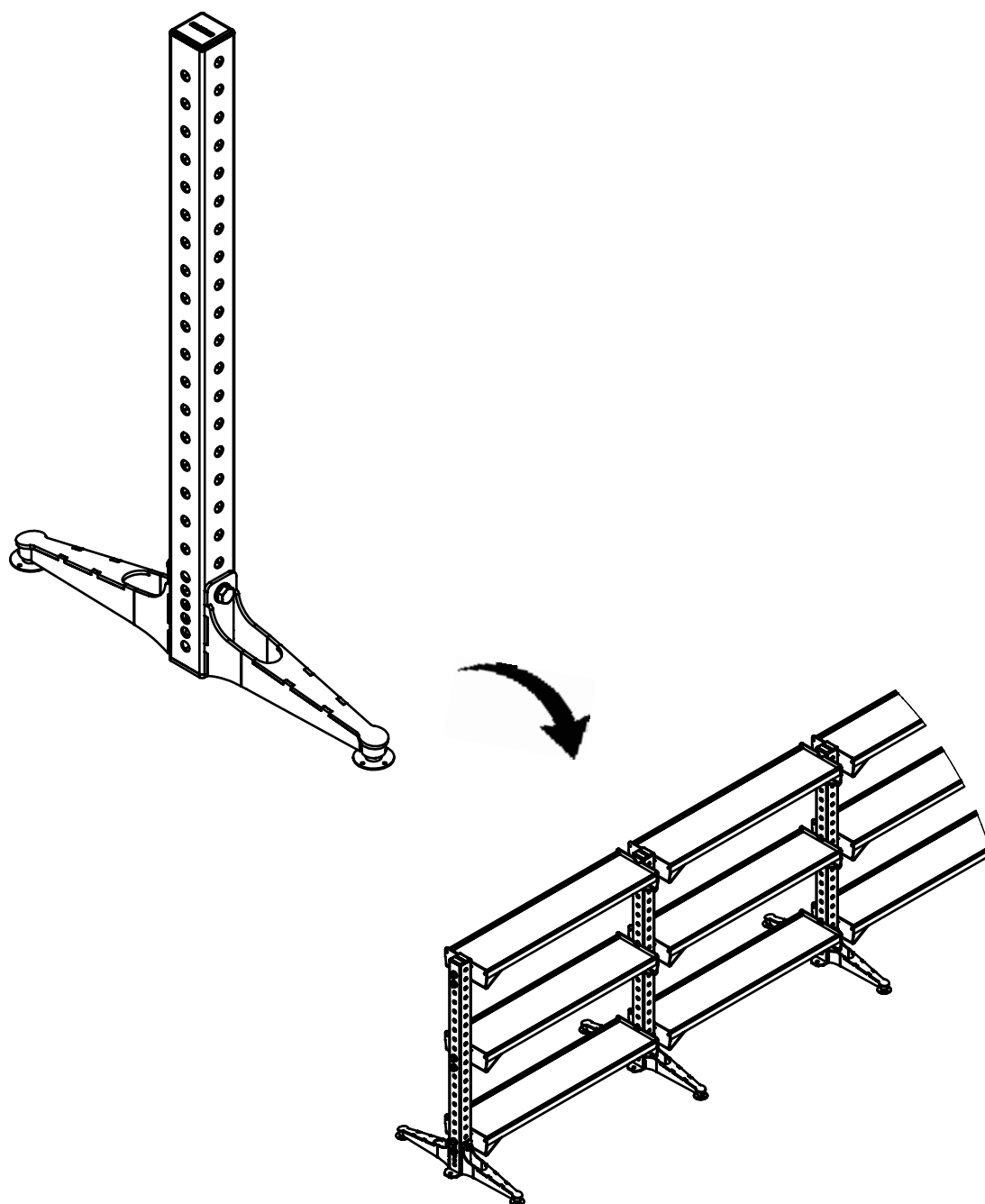

**ELEIKO**



# CONTENTS

Read before installation and use	3
Safety instructions	3
Warning labels	4
List of components	5
Assembly instructions	6
Tools needed	6
User guide	13
Purpose	13
General instructions for use	13
Product specifications	13
Care and maintenance	14
Preventive maintenance and inspections	14
Spare parts and service	14
Warranty	14

# READ BEFORE INSTALLATION AND USE

Install and use this equipment in a place where access and supervision are specifically controlled by the owner.

Be sure to install the equipment on a stable base and level the equipment properly. Eleiko recommends that all equipment is installed by a licensed contractor or an Eleiko installer.

This equipment is intended for indoor use only.

## SAFETY INSTRUCTIONS

It is the responsibility of the purchaser of ELEIKO products to instruct all users and supervising personnel on proper usage of the equipment. It is also the responsibility of the purchaser of ELEIKO products to assess the suitability of the floor, and to choose appropriate fasteners depending on floor type when using ELEIKO products that needs to be bolted to the ground.

1. All included warnings (labels) and instructions **MUST** be read before the use of any Eleiko equipment. Only use the equipment as it is intended.
2. A user **MUST** get a medical examination and proper instructions before using any Eleiko equipment.
3. **DO NOT** let anyone, under any circumstances, use equipment that appears to be damaged. Do not try to repair any equipment before consulting an Eleiko technician.
4. **DO NOT** replace components of Eleiko equipment with other, none Eleiko, equipment (magnetic safety pin, frames, bars etc.). Do not improvise! If there are any doubts, consult an Eleiko representative prior to any intervention.
5. **DO NOT** overload the equipment and **DO NOT** try to exceed personal strength levels.
6. Children under the age of 14 must be supervised by an adult.
7. **DO NOT** remove any safety labels from the Eleiko equipment. Eleiko is not responsible if a label is removed. Replace damaged labels immediately.
8. Eleiko packaging for products can be made of wood. Be aware of splinters! You **MUST** use protective gloves and proper work wear.
9. Eleiko packaging material could be a risk when handling. Be aware of crushing! You **MUST** use work wear including protective gloves and hard shoes.
10. Eleiko products and packing material are heavy, You **MUST** use proper lifting techniques, work wear and hard shoes.

# WARNING LABELS

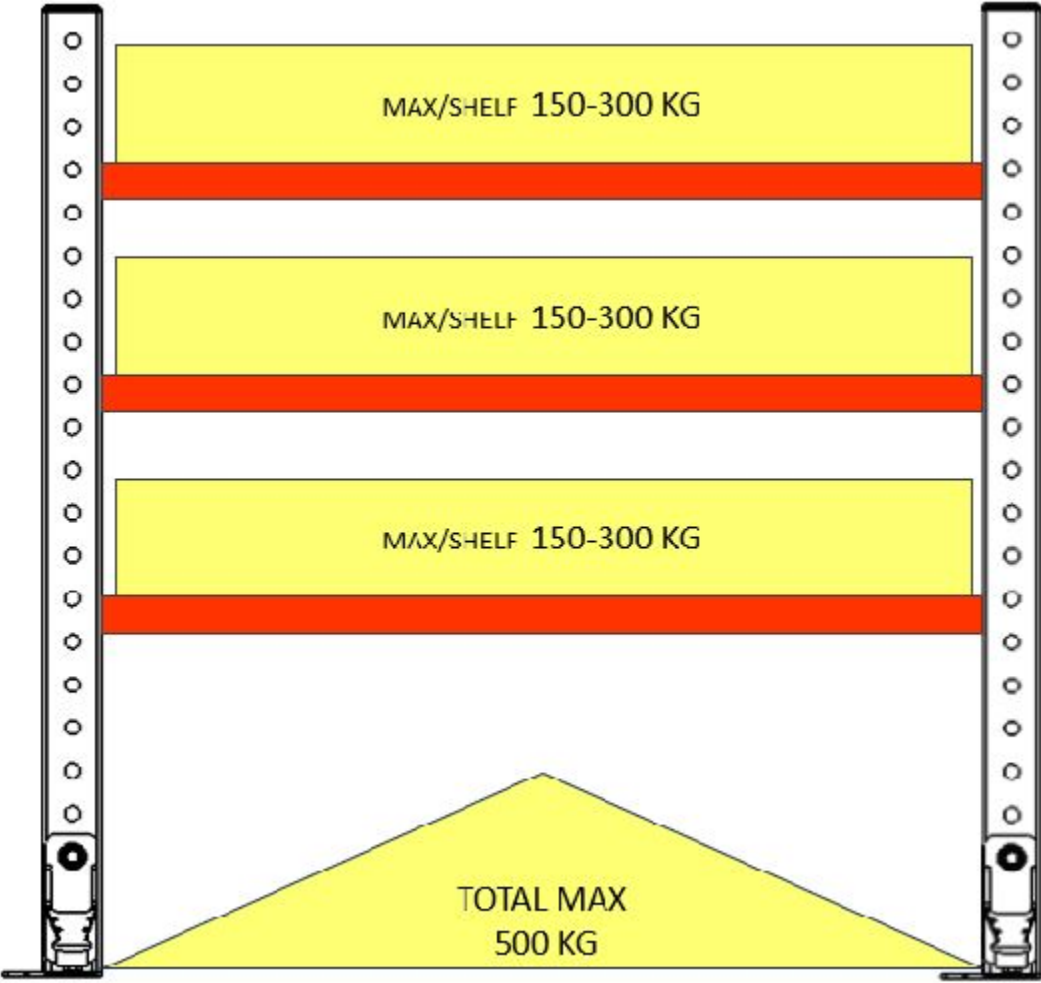

# LIST OF COMPONENTS

1x

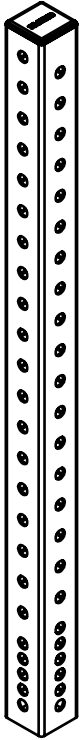

2001790  
2001792

2x

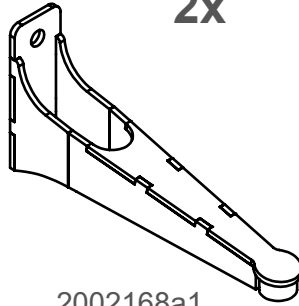

2002168a1

1x

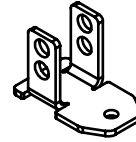

2001373

2x

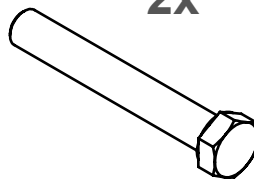

2001385-L110

2x



2001379

4x



2001421

2x

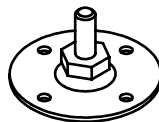

2002018

# ASSEMBLY INSTRUCTIONS

Before assembly, make sure you have enough clearance on all sides of the equipment. Take in account the accessibility to remove and replace equipment.

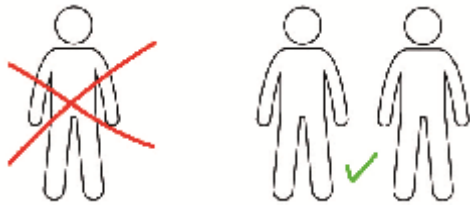

## TOOLS NEEDED

You need the following tools to assemble the equipment.



2x spanner  
size 24



spanner  
size 13

**NOTE:** Do not use electric power tools for assembly.

# SOLID AND LEVEL GROUND

Make sure the ground is solid and level. Take into account the heavy loads that will affect the flooring.

It is recommended to bolt this product to ground. Consult a licensed contractor to choose the appropriate anchoring fasteners for your facility.

See last page of assembly instructions for the anchoring points positions.

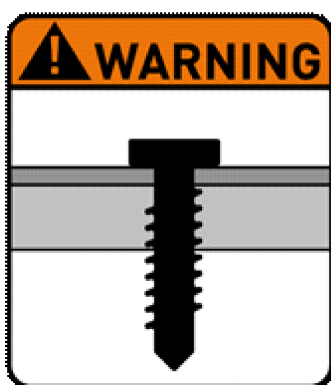

1.

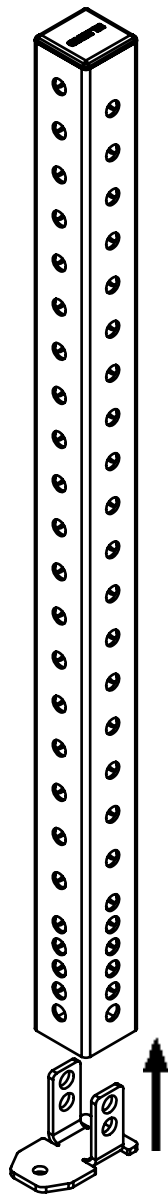
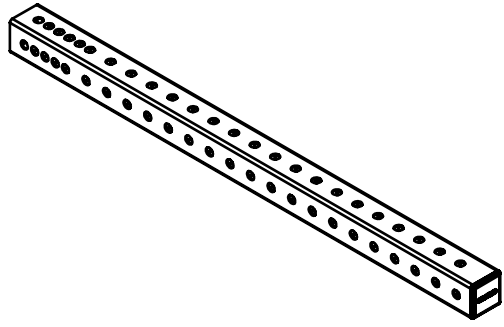
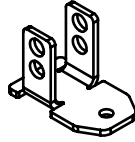

2.

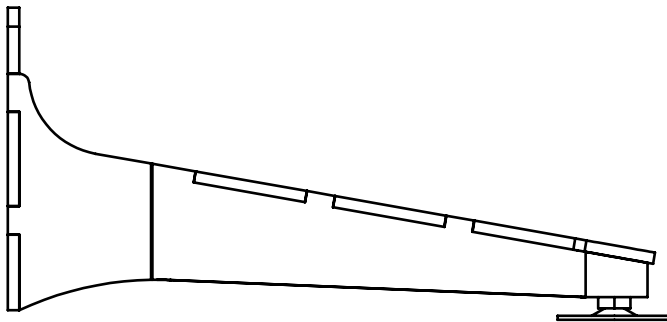
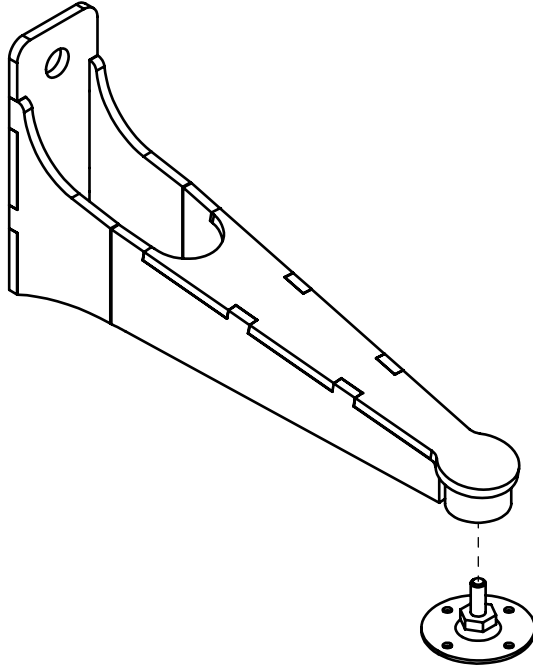
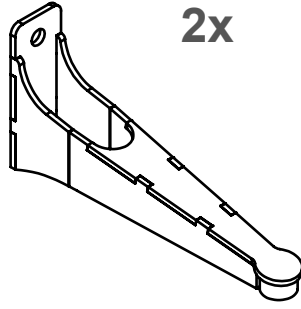
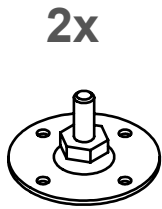

3.

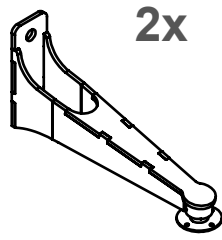

2x

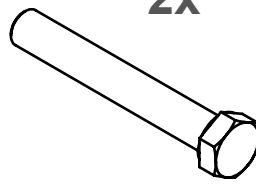

2x



2x



4x

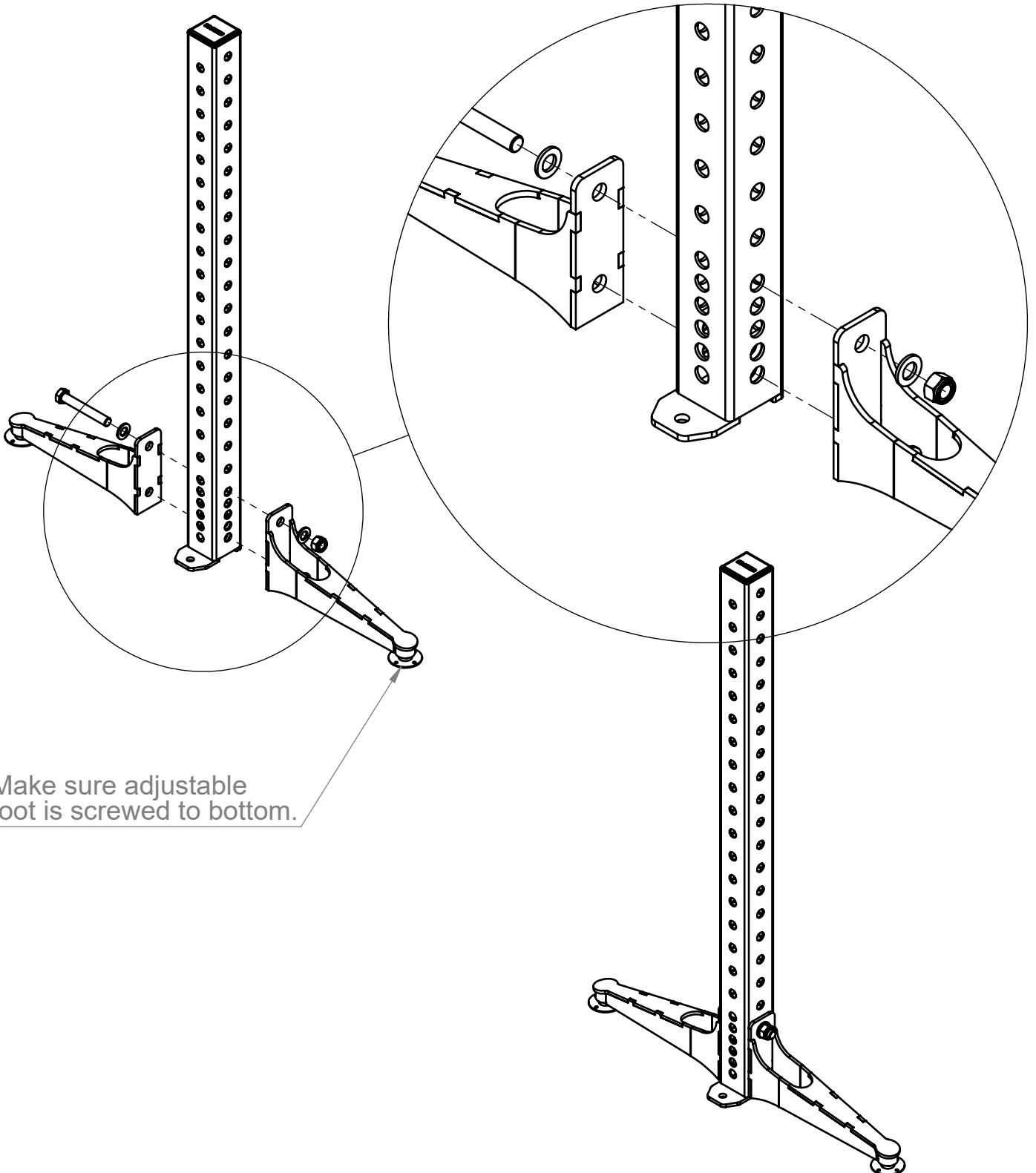

Make sure adjustable foot is screwed to bottom.

# 4. Add shelves of your choice.

---

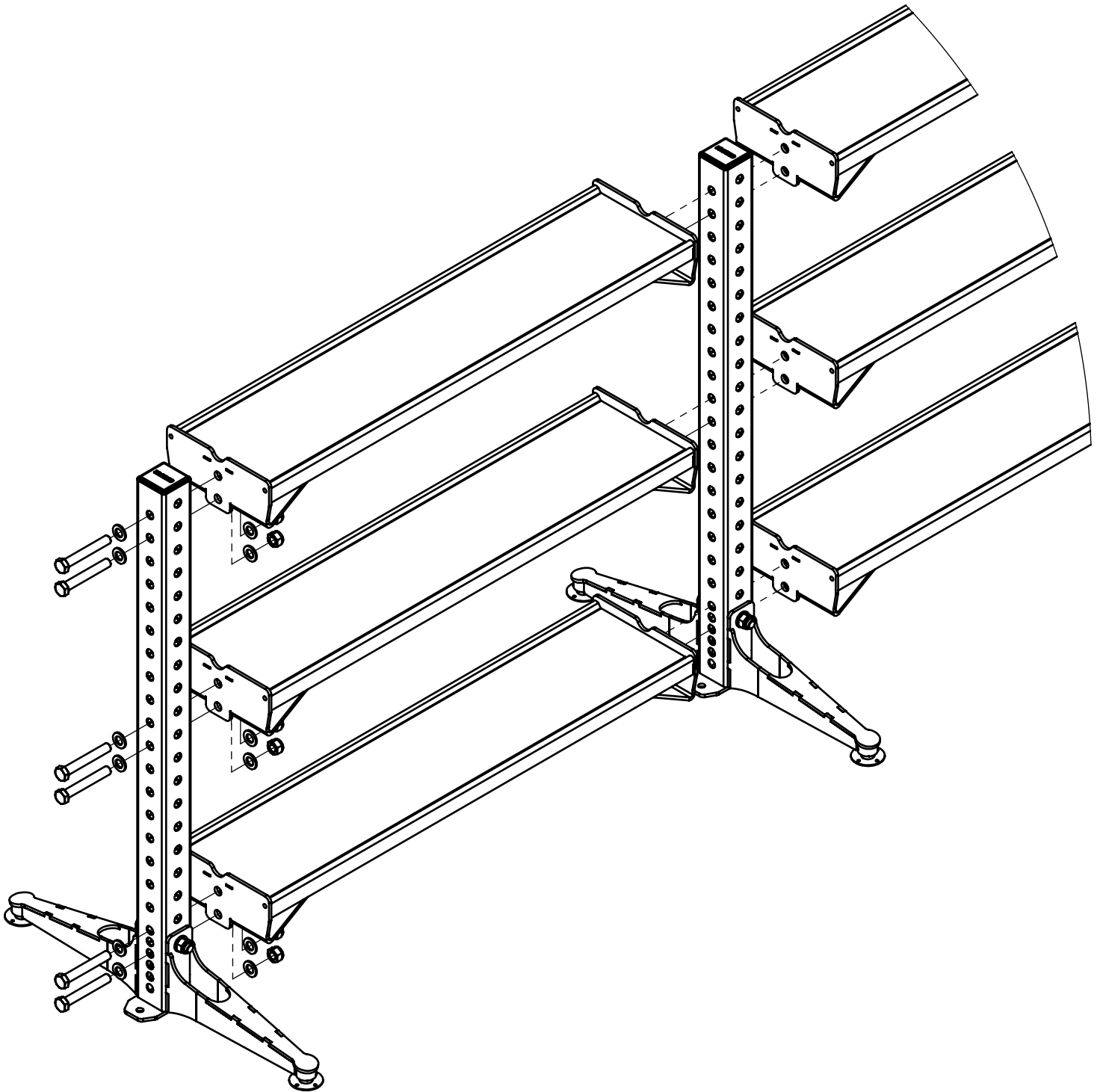

5. Load with equipment. Adjust feet to make sections stable.

---

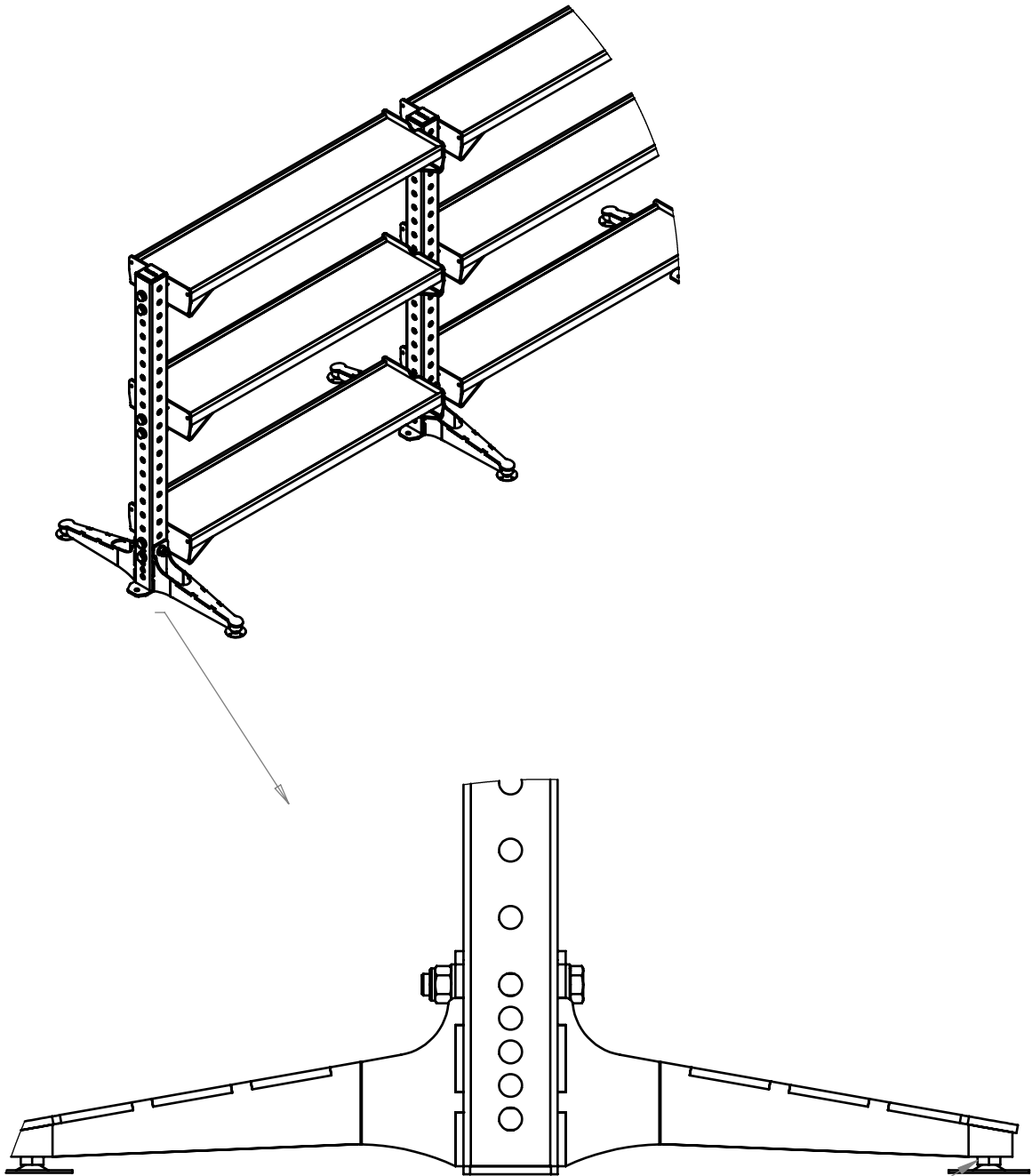

Adjust with  
spanner to make  
the section stable.



spanner  
size 13

# USER GUIDE

## PURPOSE

A storage solution for training equipment, like dumbbells, kettlebells etc. Storage legs can be combined with different types and numbers of shelves, and different heights of storage legs. See web page for more examples.

Please note that maximum total weight per section, between two legs, are 500 kg.

## GENERAL INSTRUCTIONS FOR USE

1. Make sure the floor is solid and level. Take into account the heavy loads that will affect the flooring.
2. Assemble the type of shelves of your choice and need.
3. Store the equipment

## PRODUCT SPECIFICATION

Max weight/shelf	150-300 kg / 330-660 lbs
Max weight/section	500 kg / 1102 lbs
Dimensions Storage leg S (L x W x H)	772 x 115 x 1132 mm 30.4 x 4.5 x 44.6"
Dimensions Storage leg L (L x W x H)	772 x 115 x 1582 mm 30.4 x 4.5 x 62.3"

# CARE AND MAINTENANCE

## PREVENTIVE MAINTENANCE AND INSPECTIONS

**NOTE:** The safety level of the equipment can only be maintained if it is examined regularly for damage and wear.

### Regularly:

- Clean surfaces on the frames and tubes from dust and dirt.
- Check that all bolts between parts, walls and floors are properly tightened, according to recommendations.
- Check equipment for sharp edges. Replace parts with sharp edges.
- Check equipment structural frames and welds to ensure they are free from cracks, irregularities or any other abnormalities. If in doubt, consult an Eleiko representative before product use.

### Cleaning and Care:

- Apply a mild soap detergent to a lint free cloth, then wipe down product surface.
- While it is safe to use an alcohol-based neutral pH7 solution on surface-treated steel elements of the benches and racks, take care to avoid pads and cushions.
- We recommend alcohol-free, bleach-free, and o-phenylphenol (OPP) ammonia-free wipes.

See also [www.eleiko.com](http://www.eleiko.com).

## SPARE PARTS AND SERVICE

Contact Eleiko for spare parts and service:

Eleiko Group AB | Klastorpsvägen 18 | SE-302 62 HALMSTAD | Sweden  
E-mail: [info@eleiko.com](mailto:info@eleiko.com) | Phone: +46 35 17 70 70  
[www.eleiko.com](http://www.eleiko.com)

## WARRANTY

All products manufactured by ELEIKO are warranted to the original purchaser to be free from defects in workmanship and / or materials under normal use or service as follows:

- 10 years on structural frame welds (NOT on moving parts).
- 1 year on wear and tear parts.

Normal wear and tear do not fall under the warranty.

# ELEIKO

Eleiko Group AB | Klastorpsvägen 18 | SE-302 62 HALMSTAD | Sweden  
E-mail: [info@eleiko.com](mailto:info@eleiko.com) | Phone: +46 35 17 70 70

[www.eleiko.com](http://www.eleiko.com)