

ELEIKO IPF Powerlifting Competition Platform

Art.no. 3085920

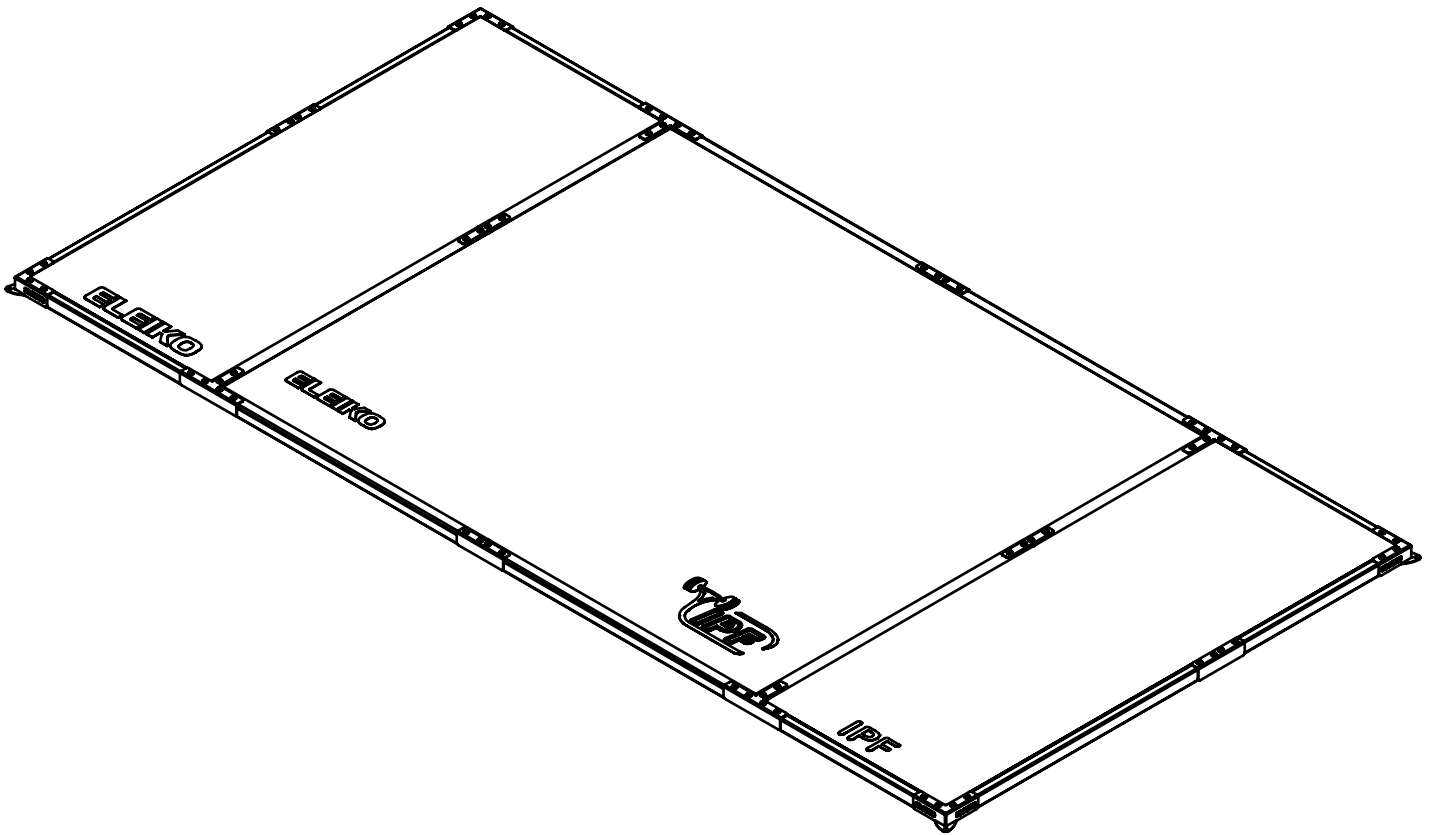

ELEIKO

CONTENTS

Read before installation and use	3
Safety instructions	3
List of components	4-5
Assembly instructions	6-15
Tools needed	6
User guide	16
Purpose	16
General instructions for use	16
Product specifications	16
Care and maintenance	17
Preventive maintenance and inspections	17
Spare parts and service	17
Warranty	17

READ BEFORE INSTALLATION AND USE

Install and use this equipment in a place where access and supervision are specifically controlled by the owner.

Be sure to install the equipment on a stable base and level the equipment properly. Eleiko recommends that all equipment is installed by a licensed contractor or an Eleiko installer.

This equipment is intended for indoor use only.

SAFETY INSTRUCTIONS

It is the responsibility of the purchaser of ELEIKO products to instruct all users and supervising personnel on proper usage of the equipment. It is also the responsibility of the purchaser of ELEIKO products to assess the suitability of the floor, and to choose appropriate fasteners depending on floor type when using ELEIKO products that needs to be bolted to the ground.

1. All included warnings (labels) and instructions **MUST** be read before the use of any Eleiko equipment. Only use the equipment as it is intended.
2. A user **MUST** get a medical examination and proper instructions before using any Eleiko equipment.
3. **DO NOT** let anyone, under any circumstances, use equipment that appears to be damaged. Do not try to repair any equipment before consulting an Eleiko technician.
4. **DO NOT** replace components of Eleiko equipment with other, none Eleiko, equipment (magnetic safety pin, frames, bars etc.). Do not improvise! If there are any doubts, consult an Eleiko representative prior to any intervention.
5. **DO NOT** overload the equipment and **DO NOT** try to exceed personal strength levels.
6. Children under the age of 14 must be supervised by an adult.
7. **DO NOT** remove any safety labels from the Eleiko equipment. Eleiko is not responsible if a label is removed. Replace damaged labels immediately.
8. Eleiko packaging for products can be made of wood. Be aware of splinters! You **MUST** use protective gloves and proper work wear.
9. Eleiko packaging material could be a risk when handling. Be aware of crushing! You **MUST** use work wear including protective gloves and hard shoes.
10. Eleiko products and packing material are heavy, You **MUST** use proper lifting techniques, work wear and hard shoes.

LIST OF COMPONENTS

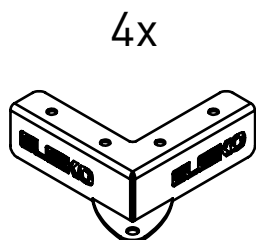

2001702a1
Corners for h=60

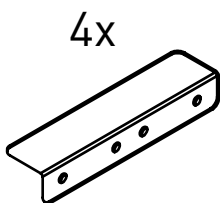

2001896p4
Extension for h=60 mm

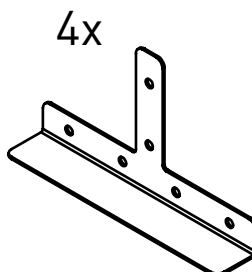

2001897p1
Corner straight
for h=60 mm

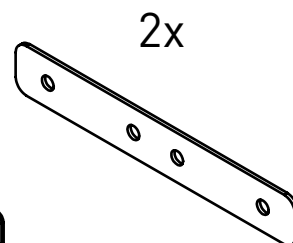

2002199
Extension

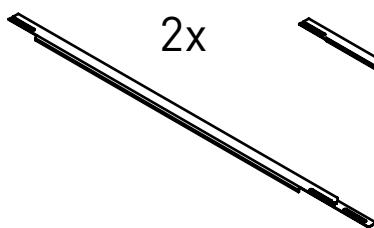

2002193p4
Plate 63x2 L=1682,5

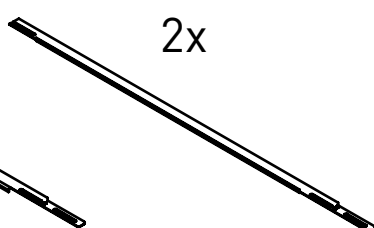

2002193p10
Plate 62x2 L=1682,5

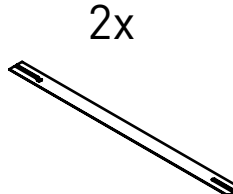

2002193p3
Plate 60x2 L=1024,5

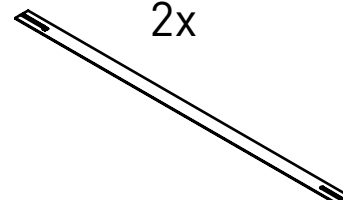

2002193p2
Cover Plate 60x2 L=1504,5

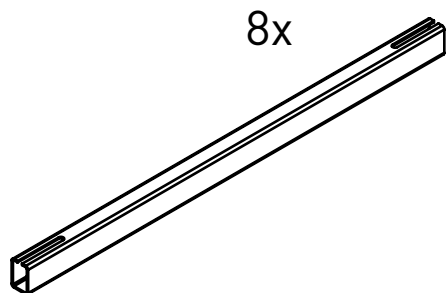

2001896p2
Rectangular tube 40x60x3, L=1012

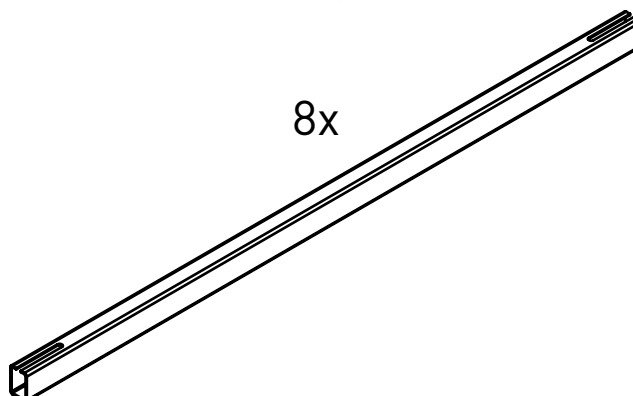

2001896p1
Rectangular tube 40x60x3, L=1492

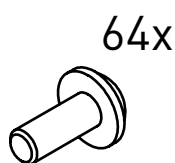

2001124-L25

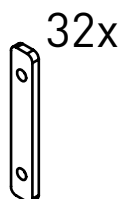

2000520 p5

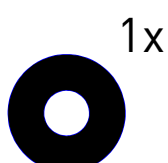

3001973
Tape double sided

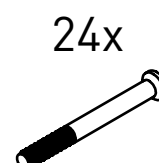

2001815-L50
Csk Chipb.screw-BZP
5x50/42 T25 Drill Sh

LIST OF COMPONENTS

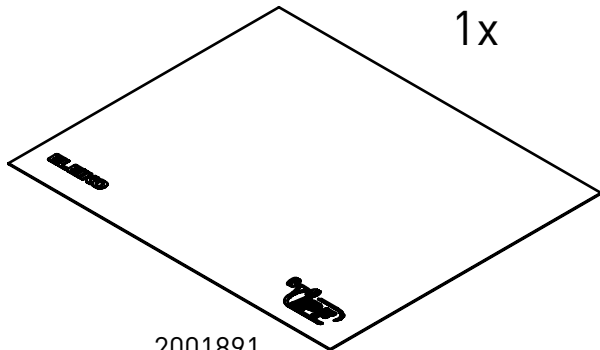

1x

2001891
Carpet 2530x3010 grey

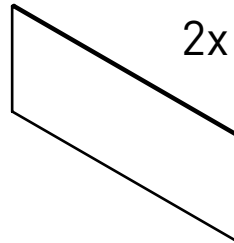

2x

2002194
Plywood 1025x2530x21

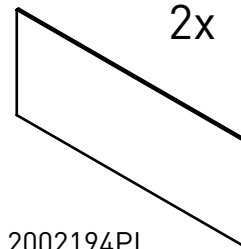

2x

2002194PL
Plywood 1025x2530x21
with decal

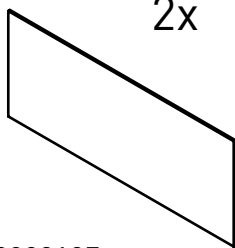

2x

2002197
Plywood 1025x2530x18

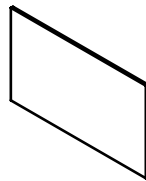

8x

2001865
Plywood 750x1260x18

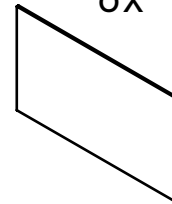

6x

2001867
Plywood 840x1500x15

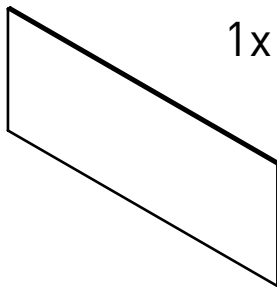

1x

3085157
Plywood 984x2520x21

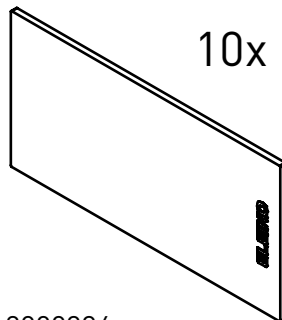

10x

2000336
Rubber Mat for PL Platform
1008x504x20,5mm

ASSEMBLY INSTRUCTIONS

Before assembly, make sure you have enough clearance on all sides of the equipment, not less than 0,6 meters. Take in account the accessibility to remove and replace bar and weights.

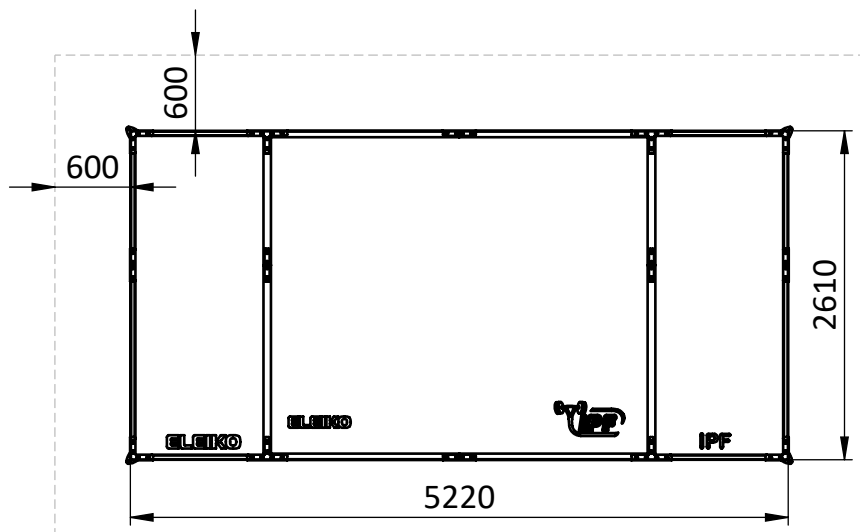

TOOLS NEEDED

You need the following tools to assemble the equipment.



Torx T50

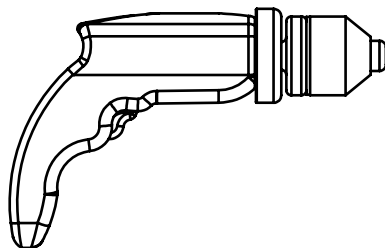

Electric screw driver



Torx bit T20

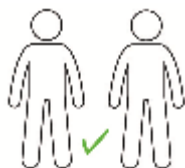

NOTE: Do not use electric power tools for assembly.

1.

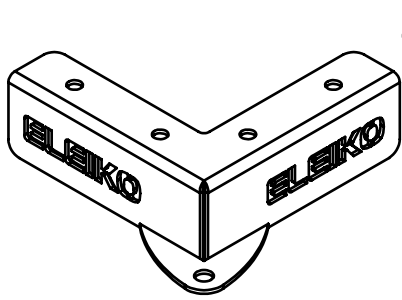

4x

2001702a1
Corners for h=60



16x

2001124-L25
Screw M10x25 BN 219
Black Zink



8x

2000520 p5
Flat iron 20x6 L=120

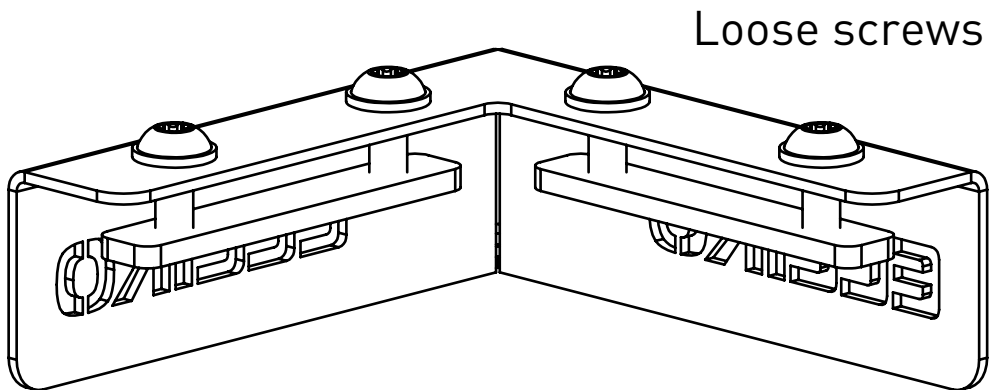
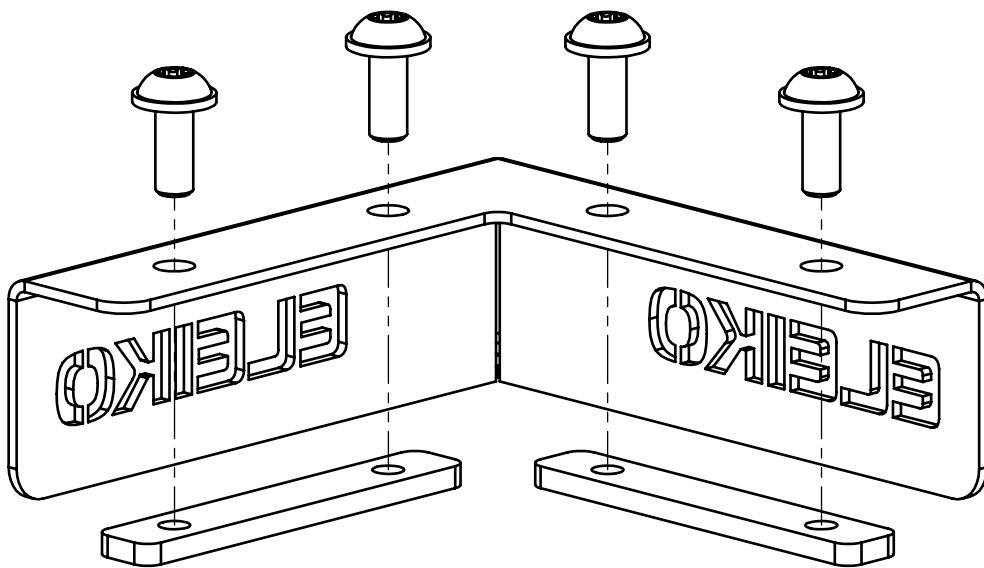

Loose screws

2.

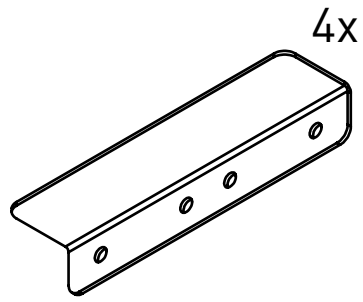

2001896p4
Extension for h=60 mm

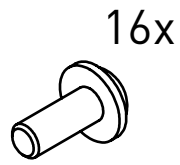

2001124-L25
Screw M10x25 BN 219
Black Zink

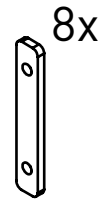

2000520 p5
Flat iron 20x6 L=120

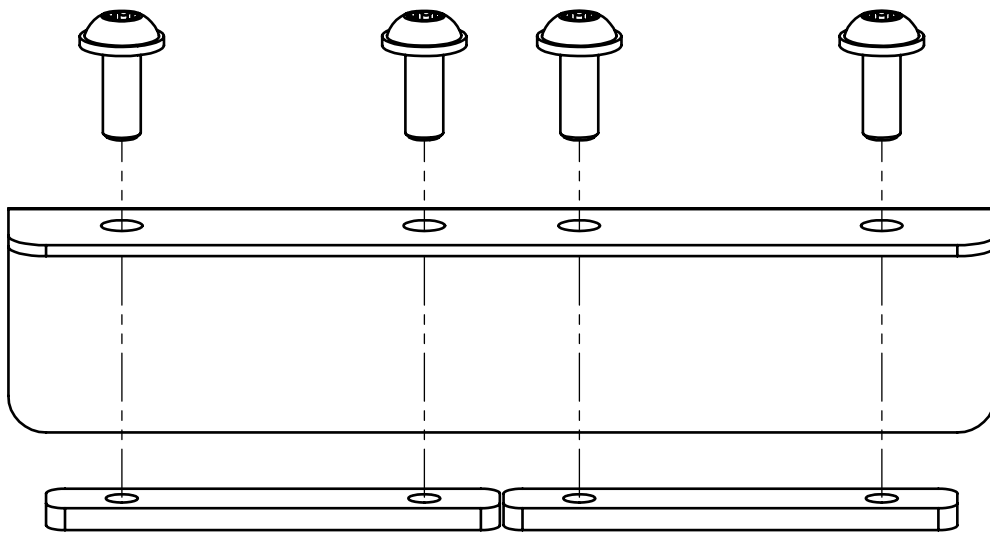

Loose screws

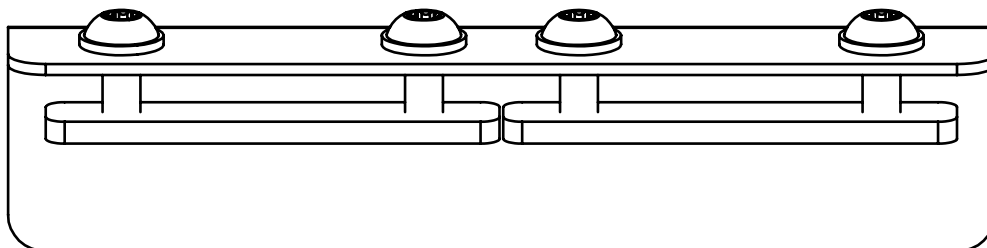

2.

2x

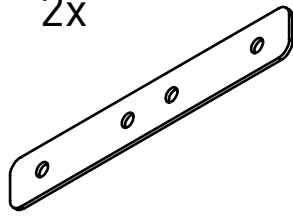

2002199
Extension

8x



2001124-L25
Screw M10x25 BN 219
Black Zink

4x



2000520 p5
Flat iron 20x6 L=120

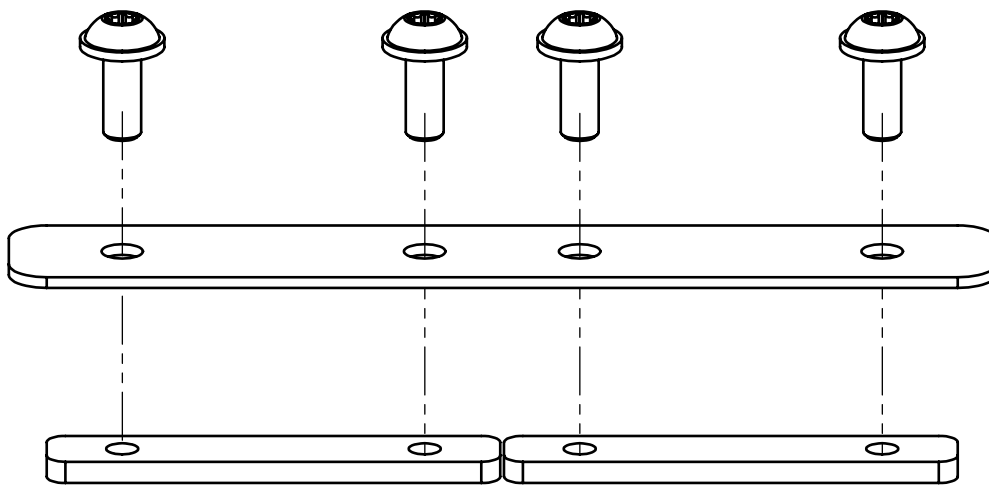

Loose screws

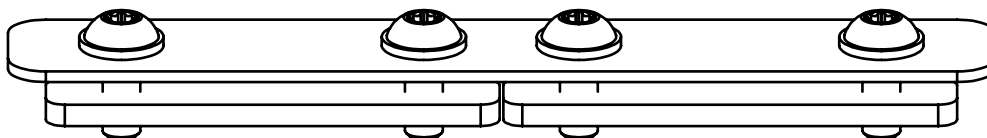

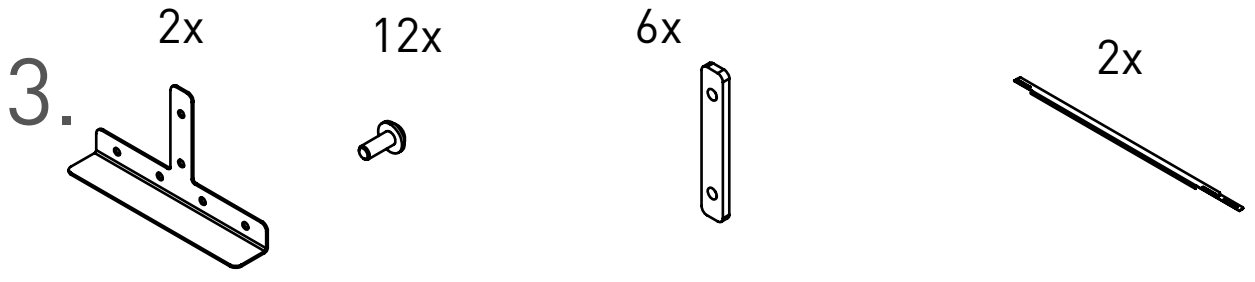

2001897p1 2001124-L25 2000520 p5 2002193p4
 Corner straight Screw M10x25 BN 219 Flat iron 20x6 L=120 Plate 63x2 L=1682,5
 for h=60 mm Black Zink

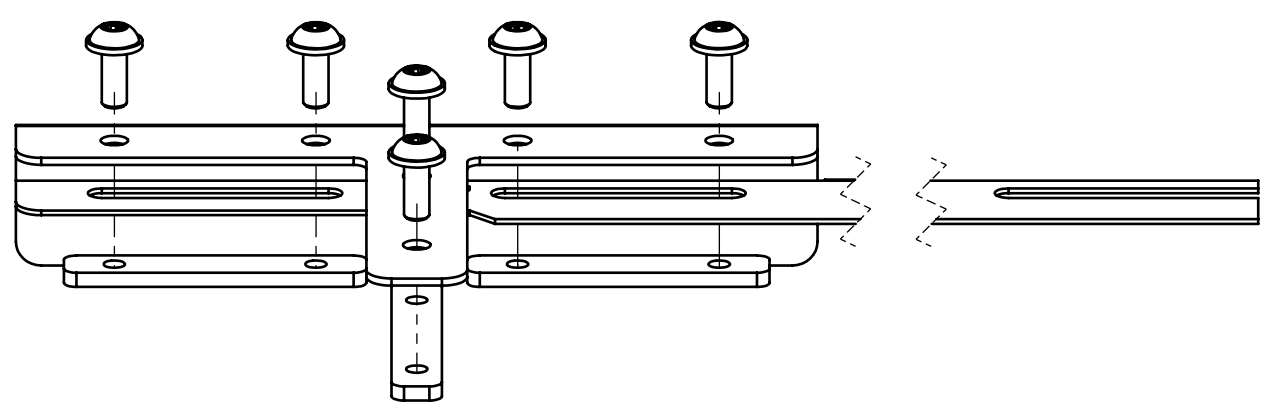

Loose screws

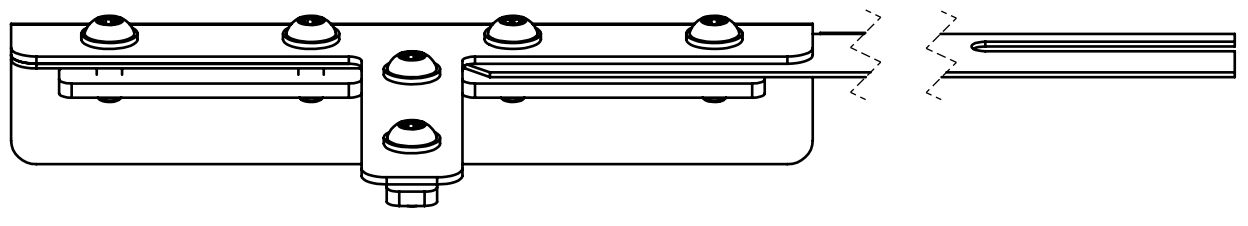

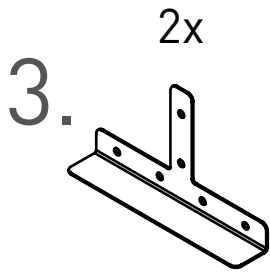

2001897p1
Corner straight
for h=60 mm

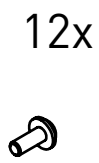

2001124-L25
Screw M10x25 BN 219
Black Zink

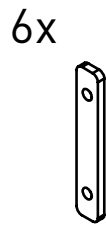

2000520 p5
Flat iron 20x6 L=120

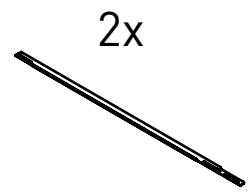

2002193p10
Plate 62x2 L=1682,5

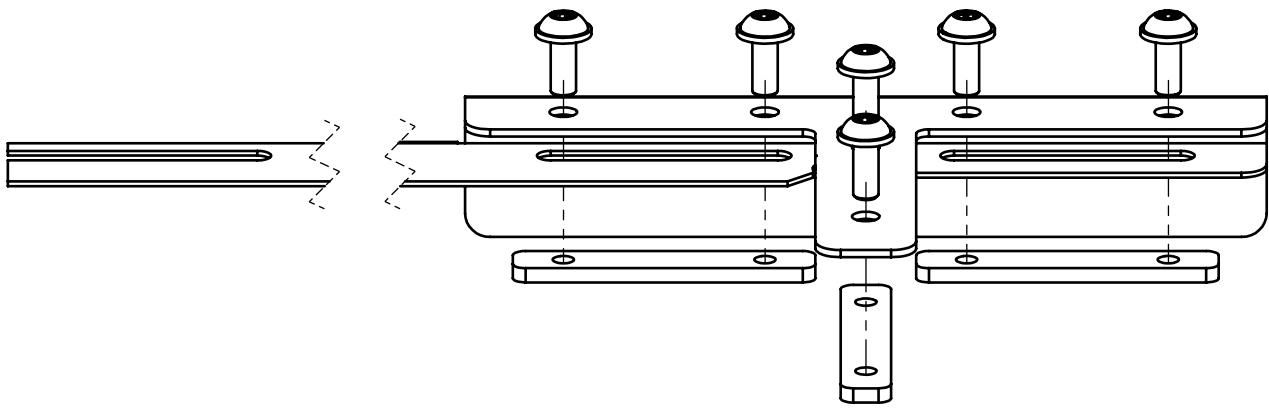

Loose screws

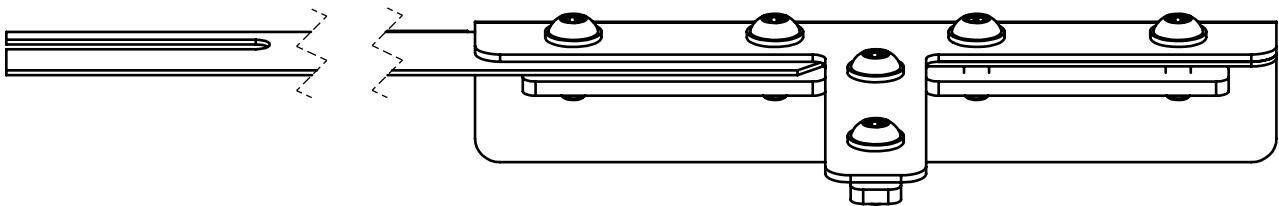

6.

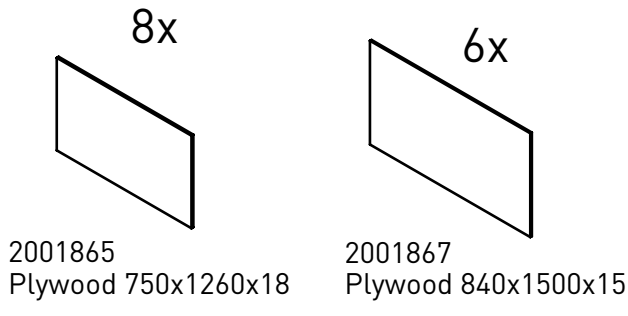

Layer 1

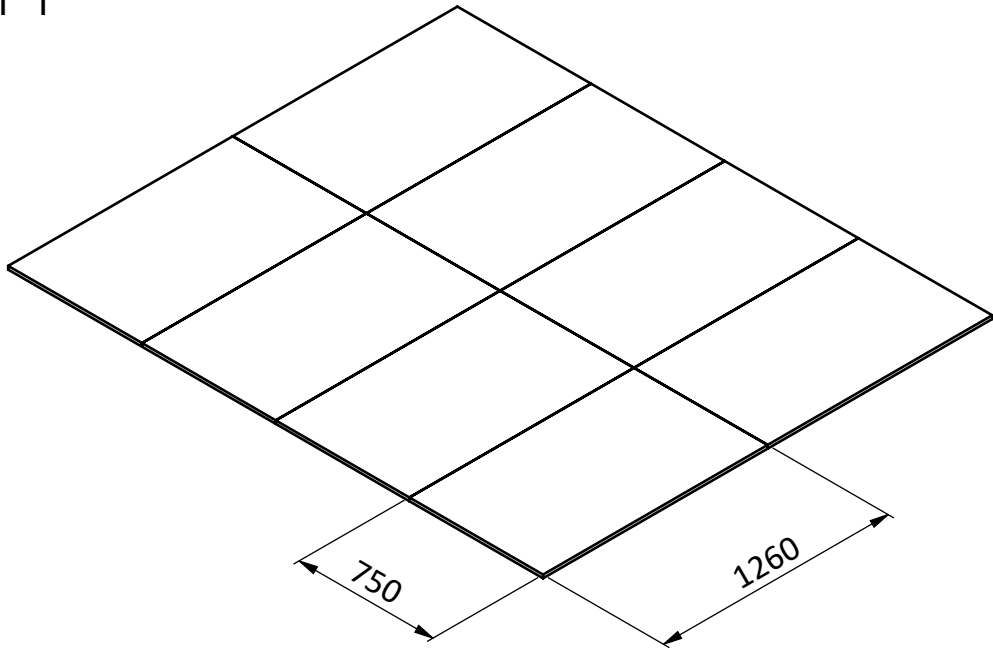

Layer 2

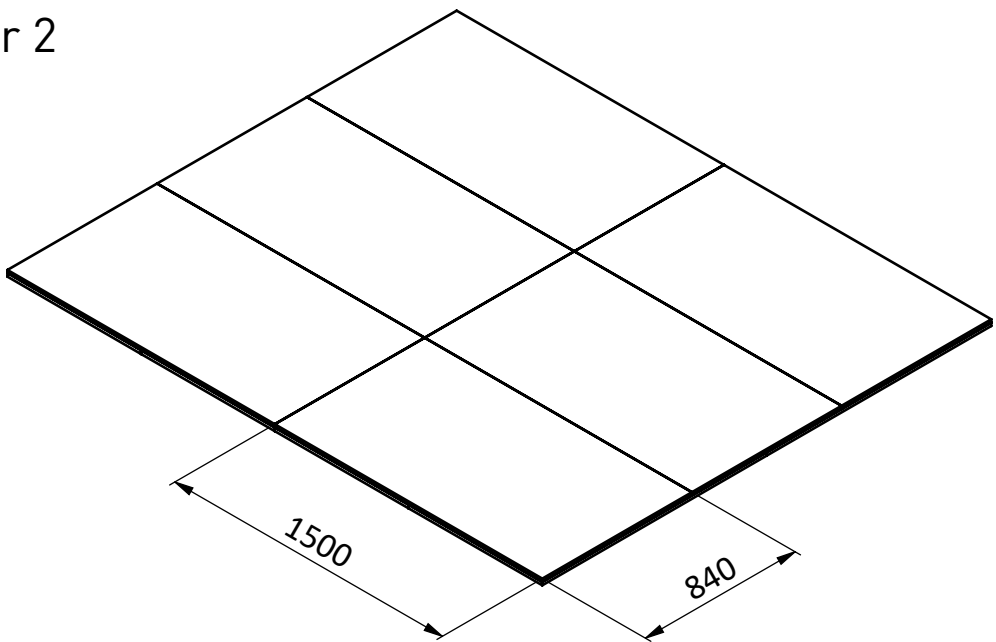

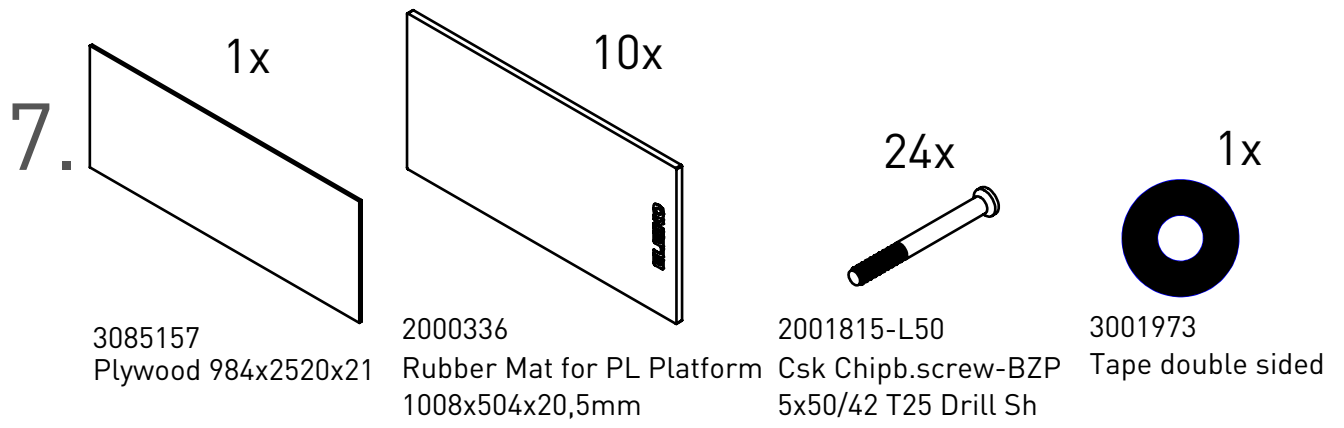

Layer 3

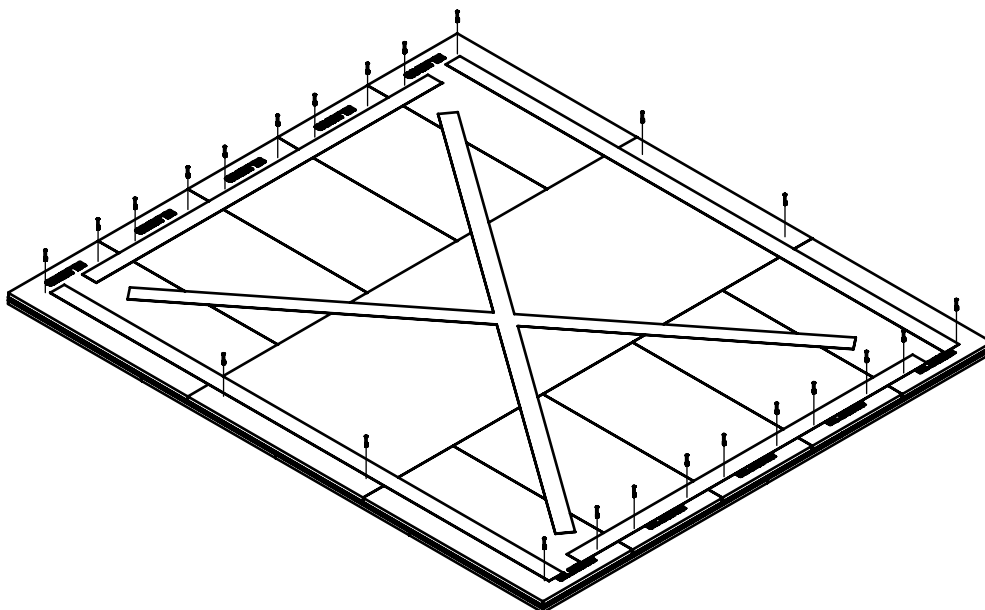
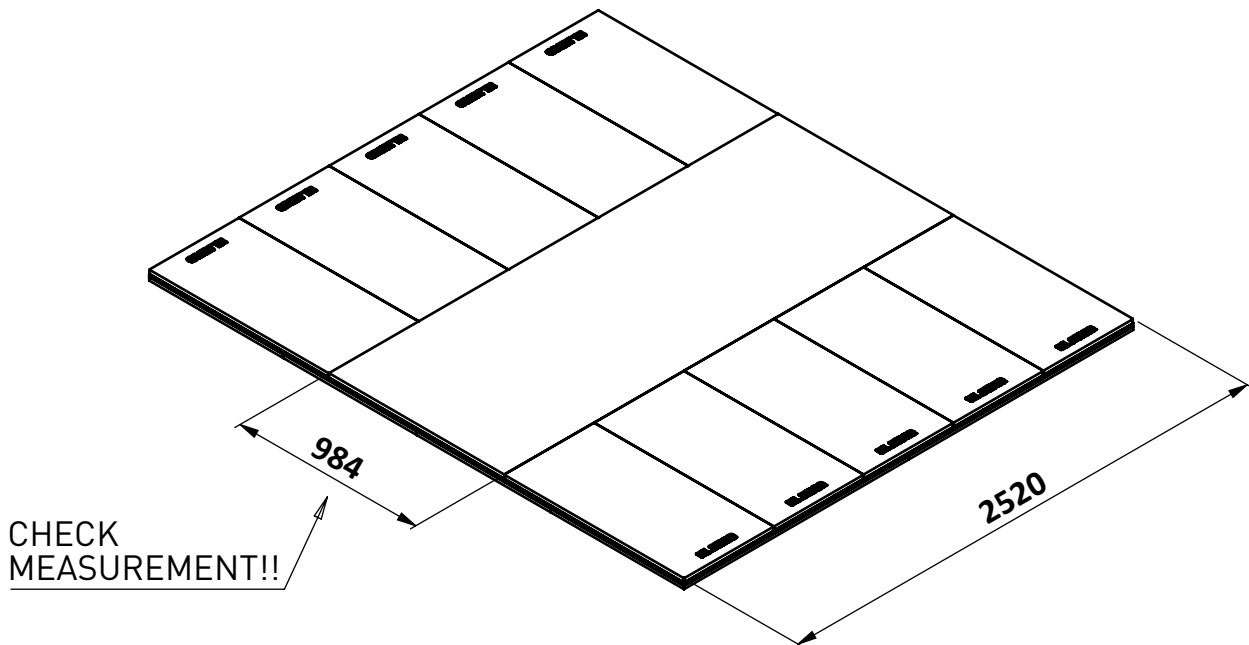

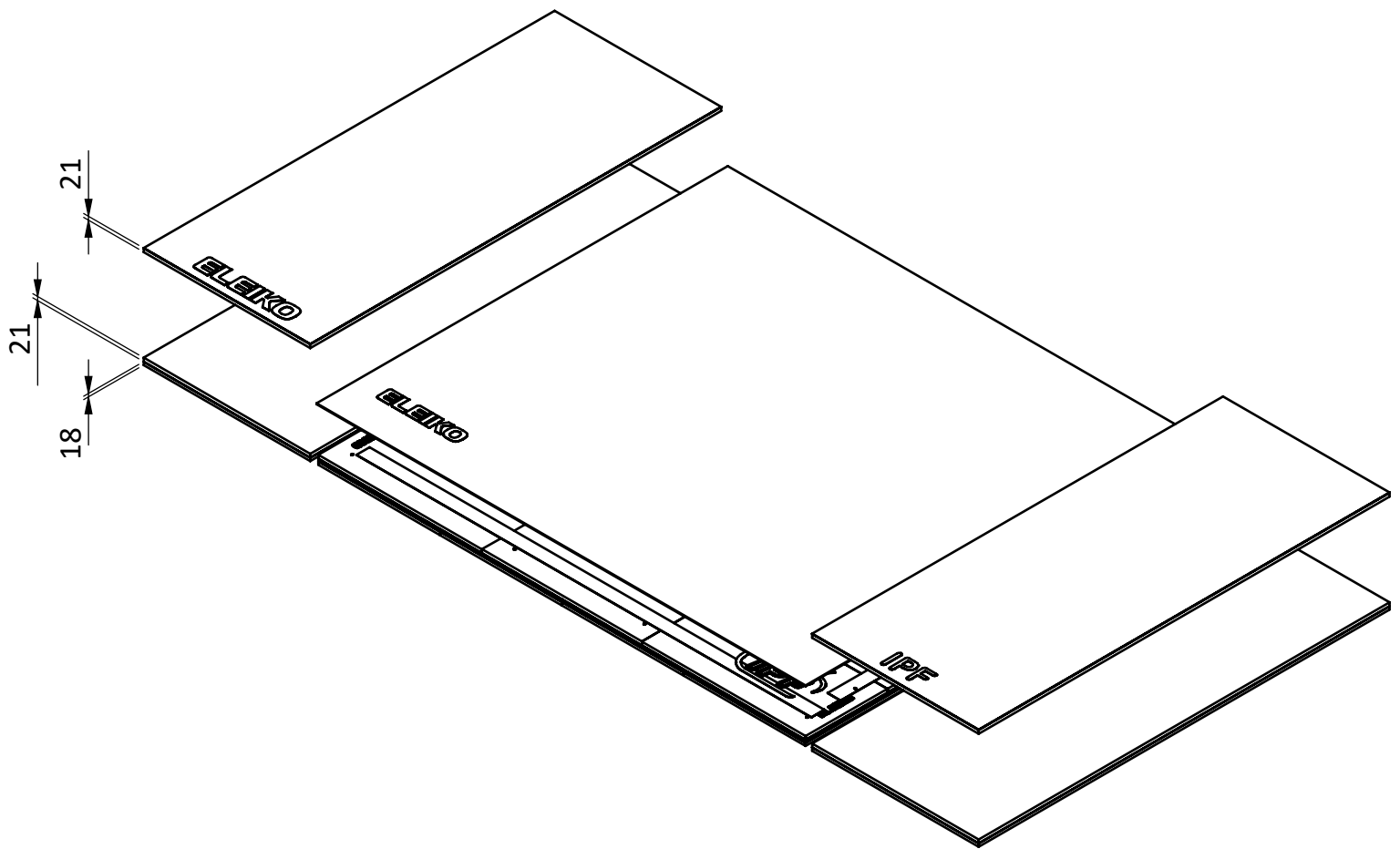
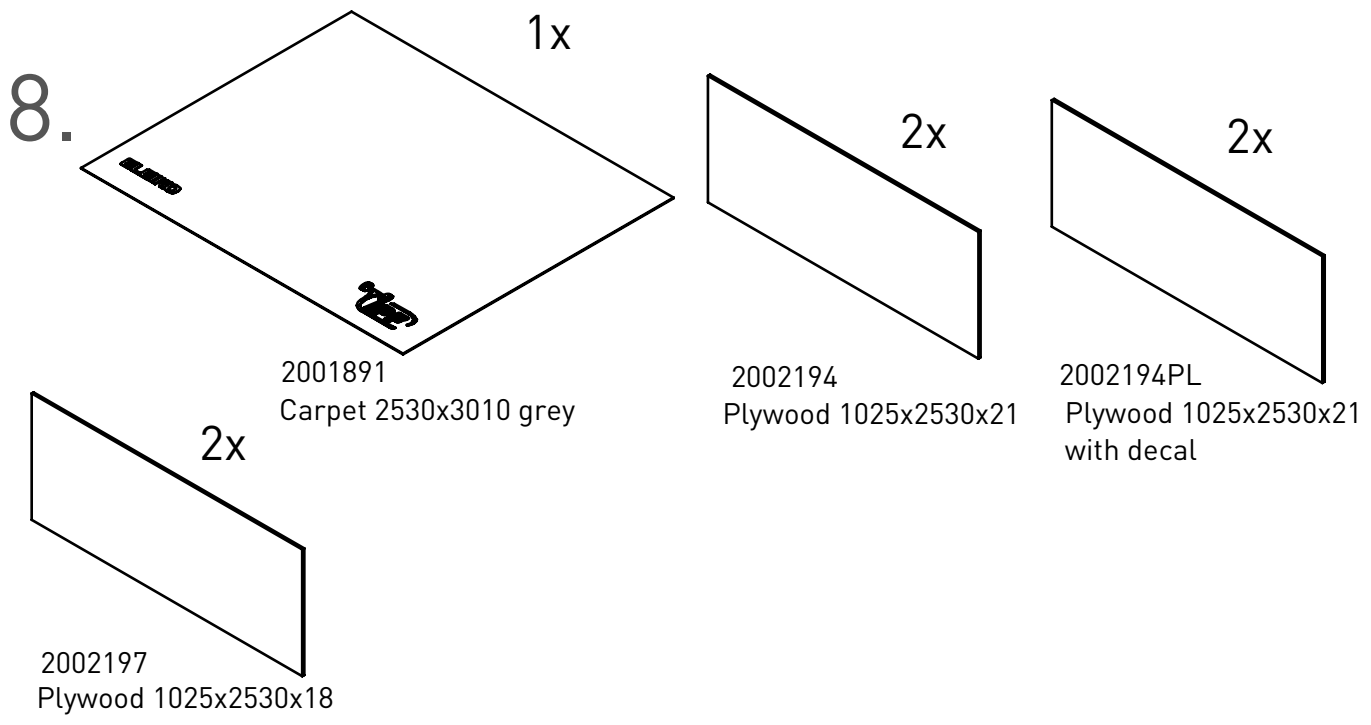

9.

6x

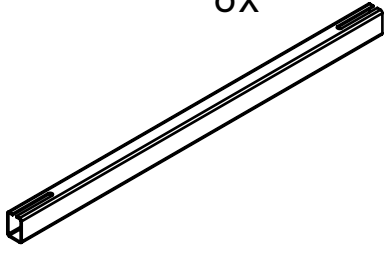

2001896p2
Rectangular tube 40x60x3, L=1012

8x

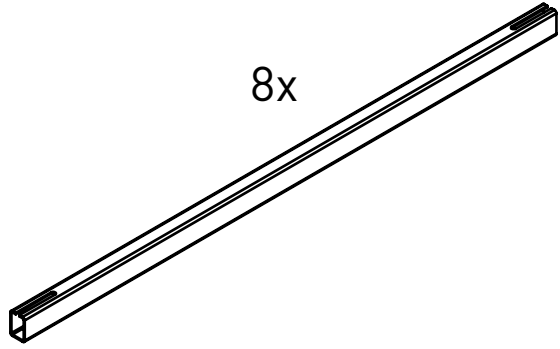

2001896p1
Rectangular tube 40x60x3, L=1492

2x

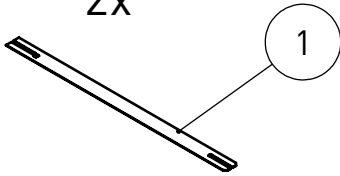

2002193p3
Plate 60x2 L=1024,5

2x

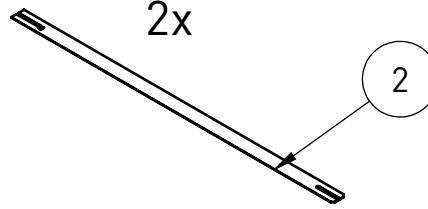

2002193p2
Cover Plate 60x2 L=1504,5

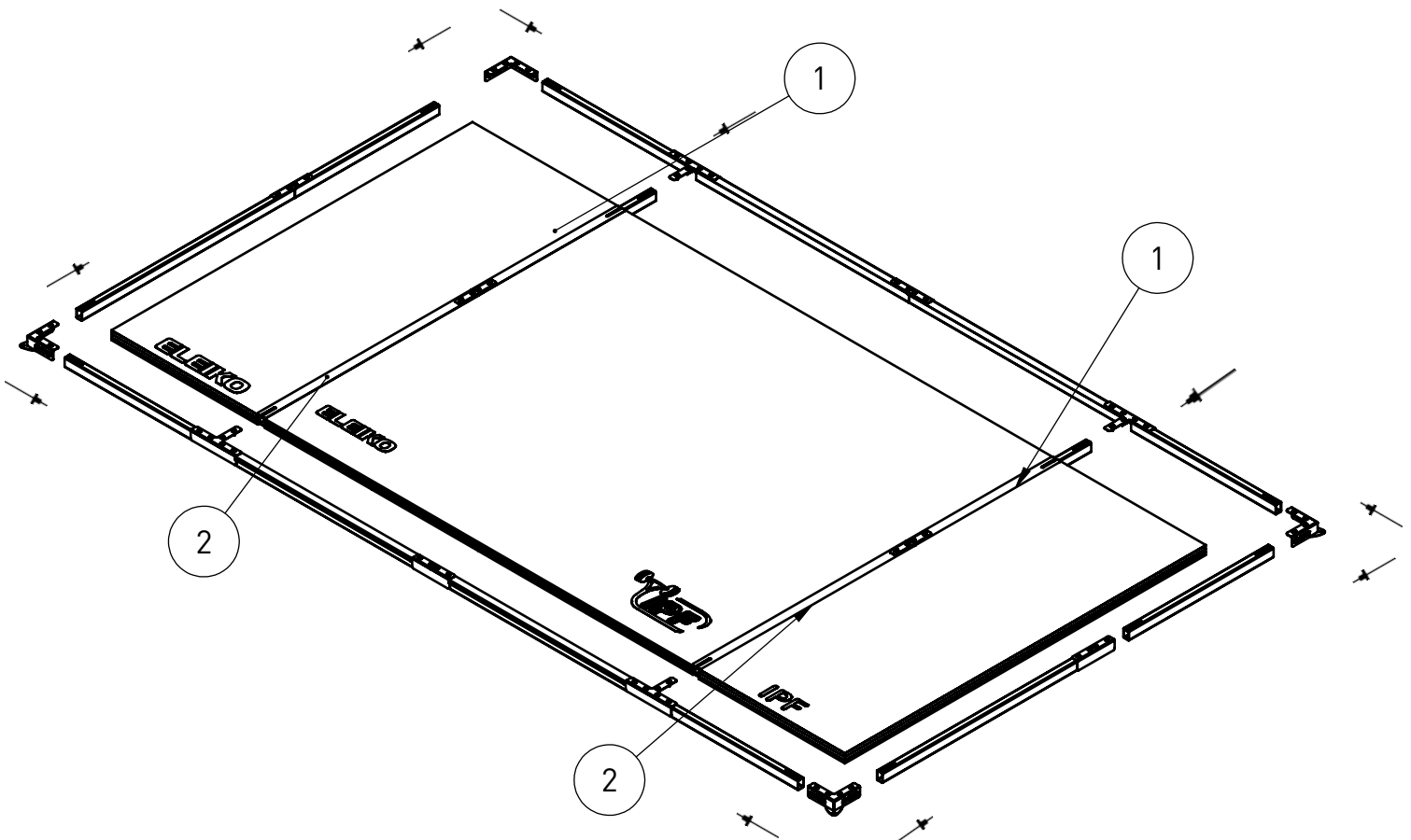

Tighten screws

USER GUIDE

PURPOSE

Powerlifting competition platform designed for giving the lifter the ultimate lifting surface while also protecting equipment and facility.

GENERAL INSTRUCTIONS FOR USE

1. For indoor use only.

PRODUCT SPECIFICATION

Product weight	560 kg / 1234 lbs
Dimensions (L x W x H)	2610 x 5220 x 60 mm 102,8 x 205,5 x 2,4"

CARE AND MAINTENANCE

PREVENTIVE MAINTENANCE AND INSPECTIONS

NOTE: The safety level of the equipment can only be maintained if it is examined regularly for damage and wear.

- Platforms must be installed on a level solid subsurface.
- Platform use does not eliminate potential sub floor damage; extra protection may be needed to mitigate the impact force. We recommend 10mm rubber + 2x20mm plywood as an under layer. This must be evaluated and tested on-site before installation.

Daily:

- Clean the textile carpet with a proper vacuum cleaner during the day, if needed use a cleaning machine like "clean profi 50.1" (HAKO) (including water, soap and brush).

Regularly:

- Clean surfaces on the frames and tubes from dust and dirt.
- Check that all bolts between parts, walls and floors are properly tightened, according to recommendations.

USAGE DURING COMPETITION

- Platform AND wrapping area should be cleaned in the breaks between every discipline. There is plenty of time for loaders to do this.
- Platform, Wrapping area AND warm-up area must be cleaned between competition days.
- Failure to keep these areas clean will result magnesia and Baby powder unavoidably getting on the soles of other lifters shoes, limiting their grip and thereby hindering their best performance. This is because magnesia and Baby powder is used so liberally during the competition and entire areas are quickly covered if not kept clean.

How to clean:

- During the day a well-functioning vacuum cleaner is sufficient.
- For the cleaning between days it is recommended to wet-wipe the floor and vacuum clean.

See also www.eleiko.com.

SPARE PARTS AND SERVICE

Contact Eleiko for spare parts and service:

Eleiko Group AB | Klastorpsvägen 18 | SE-302 62 HALMSTAD | Sweden
E-mail: info@eleiko.com | Phone: +46 35 17 70 70
www.eleiko.com

WARRANTY

All products manufactured by ELEIKO are warranted to the original purchaser to be free from defects in workmanship and / or materials under normal use or service as follows:

- 10 years on structural frame welds (NOT on moving parts).
- 1 year on wear and tear parts.

Normal wear and tear do not fall under the warranty.

ELEIKO

Eleiko Group AB | Klastorpsvägen 18 | SE-302 62 HALMSTAD | Sweden
E-mail: info@eleiko.com | Phone: +46 35 17 70 70

www.eleiko.com