

# ELEIKO DUAL ADJUSTABLE PULLEY

Art.no. 3085806

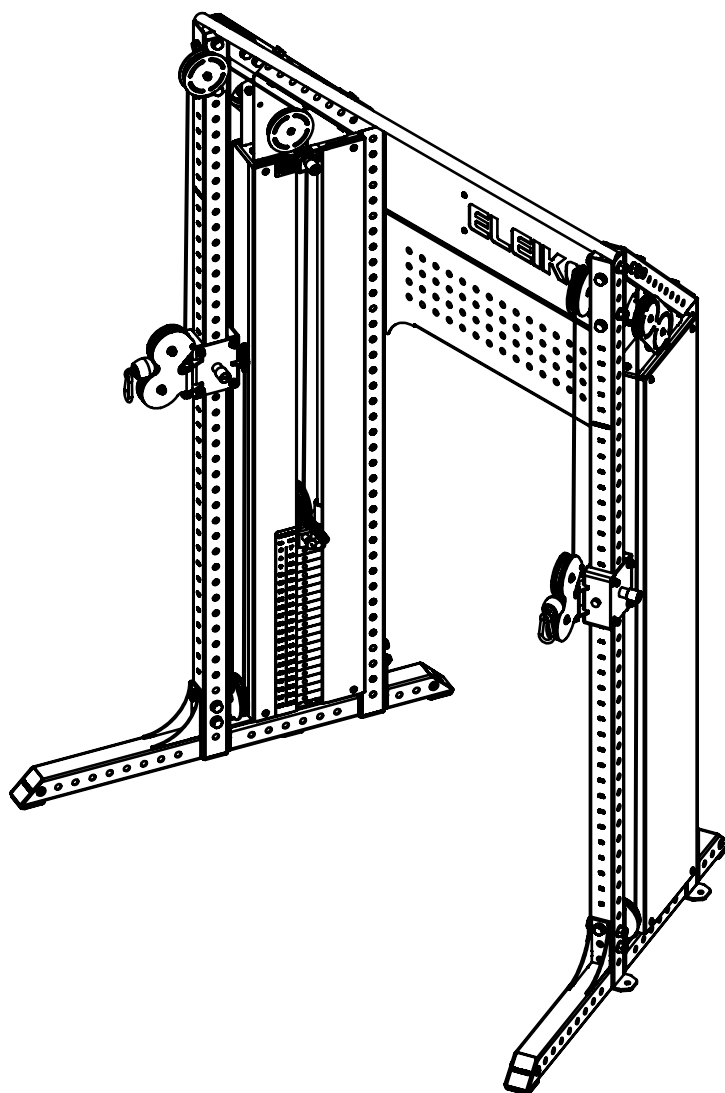

**ELEIKO**



# CONTENTS

Read before installation and use	4
Safety instructions	4
Warning labels	5
List of components	6
Assembly instructions	9
Tools needed	9
User guide	64
Purpose	64
General instructions for use	64
Product specifications	64
Care and maintenance	65
Preventive maintenance and inspections	65
Spare parts and service	65
Warranty	65

NOTE! YOU WILL ONLY NEED TO USE THIS MANUAL!  
YOU WILL NOT NEED THE MANUAL THAT CAME IN THE WOODEN BOX  
TOGETHER WITH THE CABLE ATTACHMENT!

# READ BEFORE INSTALLATION AND USE

Install and use this equipment in a place where access and supervision are specifically controlled by the owner.

Be sure to install the equipment on a stable base and level the equipment properly. Eleiko recommends that all equipment is installed by a licensed contractor or an Eleiko installer.

This equipment is intended for indoor use only.

## SAFETY INSTRUCTIONS

It is the responsibility of the purchaser of ELEIKO products to instruct all users and supervising personnel on proper usage of the equipment. It is also the responsibility of the purchaser of ELEIKO products to assess the suitability of the floor, and to choose appropriate fasteners depending on floor type when using ELEIKO products that needs to be bolted to the ground.

1. All included warnings (labels) and instructions MUST be read before the use of any Eleiko equipment. Only use the equipment as it is intended.
2. A user MUST get a medical examination and proper instructions before using any Eleiko equipment.
3. DO NOT let anyone, under any circumstances, use equipment that appears to be damaged. Do not try to repair any equipment before consulting an Eleiko technician.
4. DO NOT replace components of Eleiko equipment with other, none Eleiko, equipment (magnetic safety pin, frames, bars etc.). Do not improvise! If there are any doubts, consult an Eleiko representative prior to any intervention.
5. DO NOT overload the equipment and DO NOT try to exceed personal strength levels.
6. Children under the age of 14 must be supervised by an adult.
7. DO NOT remove any safety labels from the Eleiko equipment. Eleiko is not responsible if a label is removed. Replace damaged labels immediately.
8. Eleiko packaging for products can be made of wood. Be aware of splinters! You MUST use protective gloves and proper work wear.
9. Eleiko packaging material could be a risk when handling. Be aware of crushing! You MUST use work wear including protective gloves and hard shoes.
10. Eleiko products and packing material are heavy, You MUST use proper lifting techniques, work wear and hard shoes.

# WARNING LABELS

**! WARNING**

**SERIOUS INJURY COULD OCCUR IF THESE PRECAUTIONS ARE NOT OBSERVED**

Read all warnings and obtain proper instructions on use of the equipment prior to using.

**DO NOT** attempt to fix broken or inoperable equipment.

Use the equipment only for its intended use. Obtain proper instruction and **DO NOT** modify the equipment.

Obtain a medical exam before beginning an exercise program.

Stop exercise if you feel faint or dizzy. Consult a physician if you are experiencing pain.

Inspect the equipment before use. **DO NOT** use if equipment appears damaged or inoperable.

Keep body and clothing free and clear of all moving parts.

Do not use accessories or attachments not recommended by Eleiko.

The equipment is to be used only under qualified supervision.

Make sure all equipment is set up and operated on a solid level surface. **DO NOT** use equipment if set up on an uneven or unstable surface.

Children must not be allowed near this equipment. Teenagers must be supervised.

**DO NOT REMOVE THIS LABEL**

**IF DAMAGED CONTACT ELEIKO TO OBTAIN A REPLACEMENT** ASTMF1749

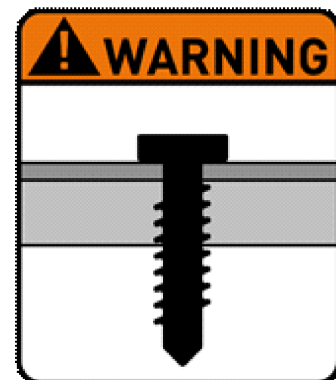

# LIST OF COMPONENTS

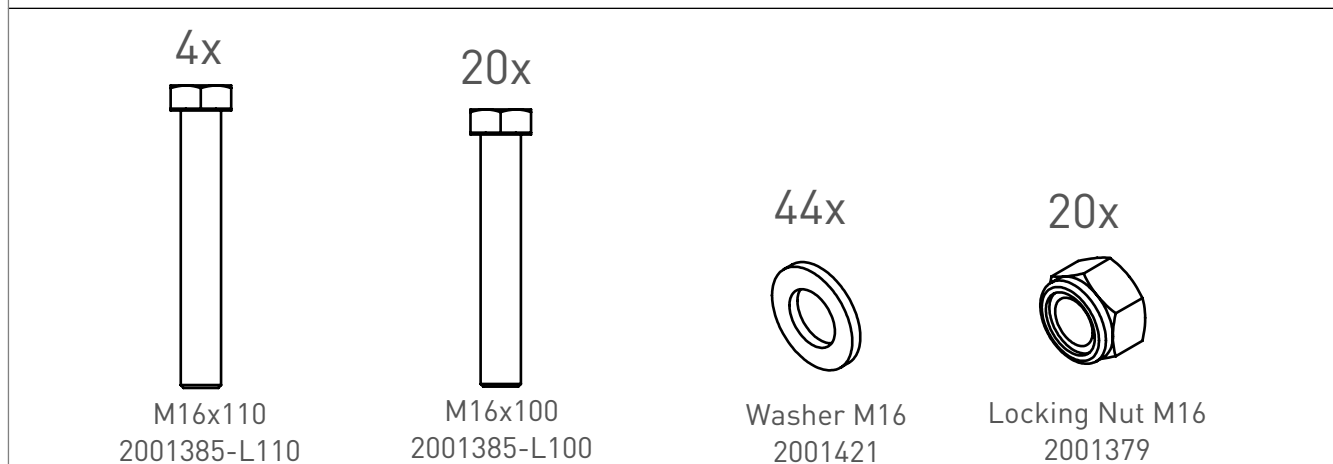
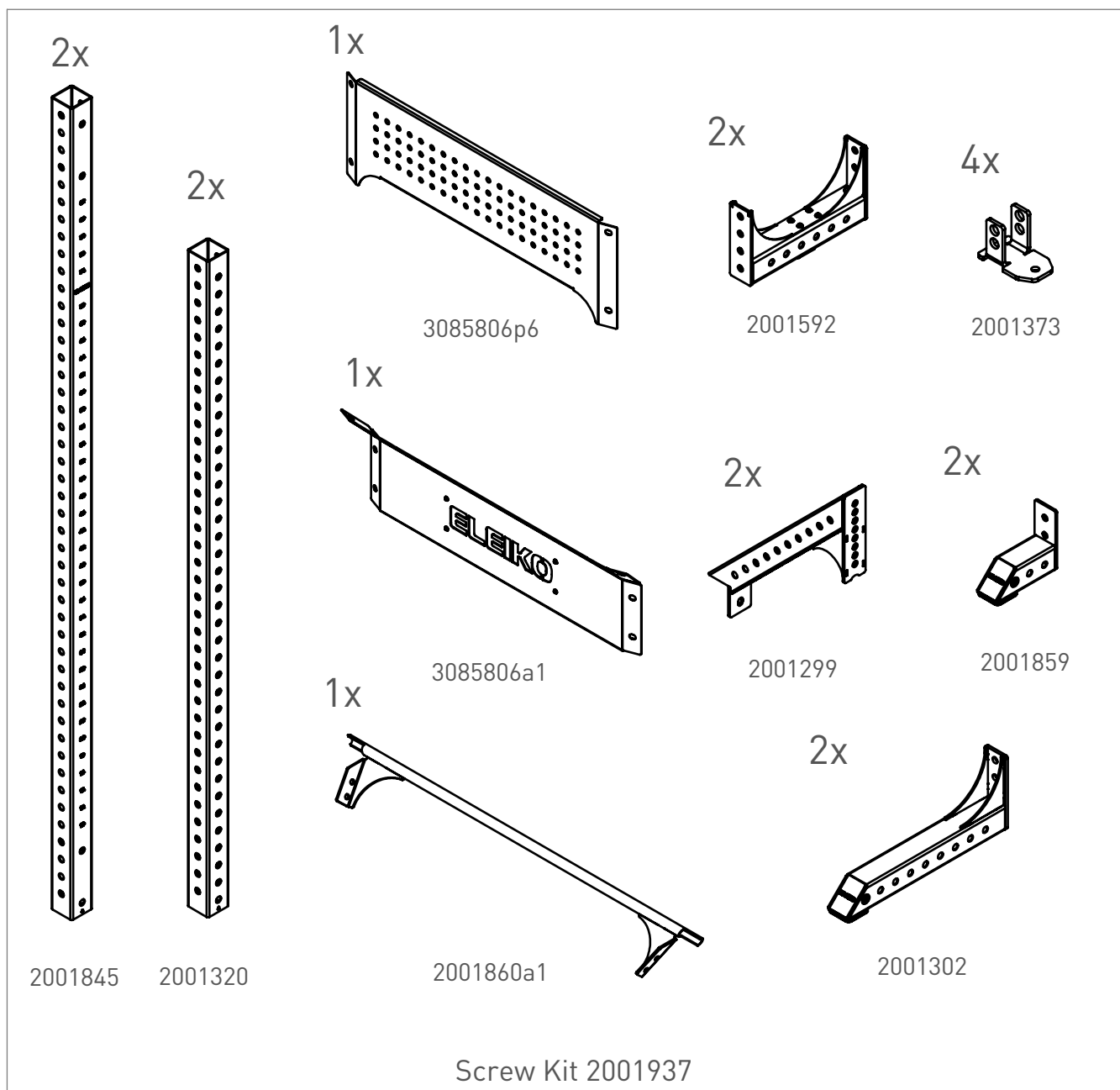

# LIST OF COMPONENTS

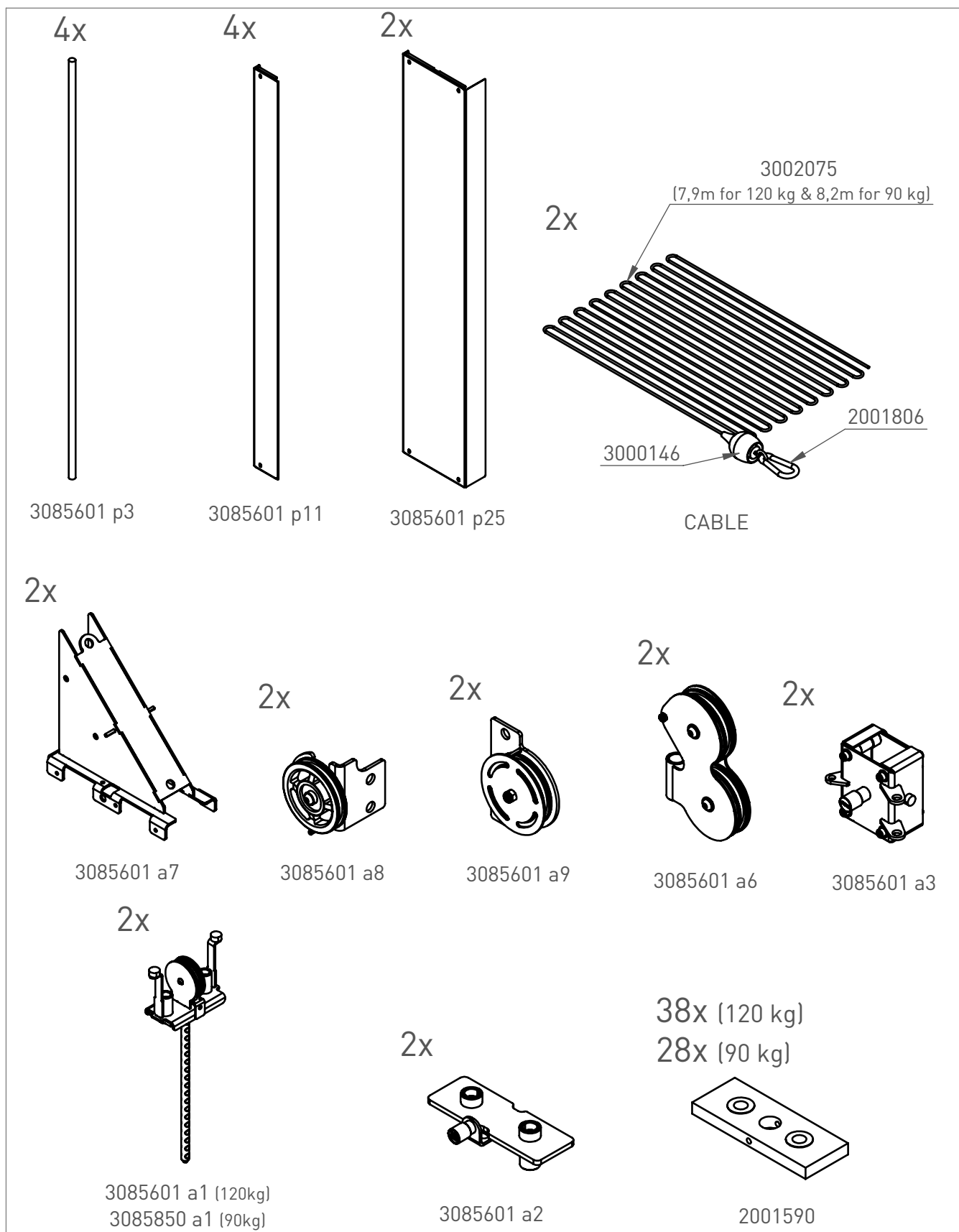

# LIST OF COMPONENTS

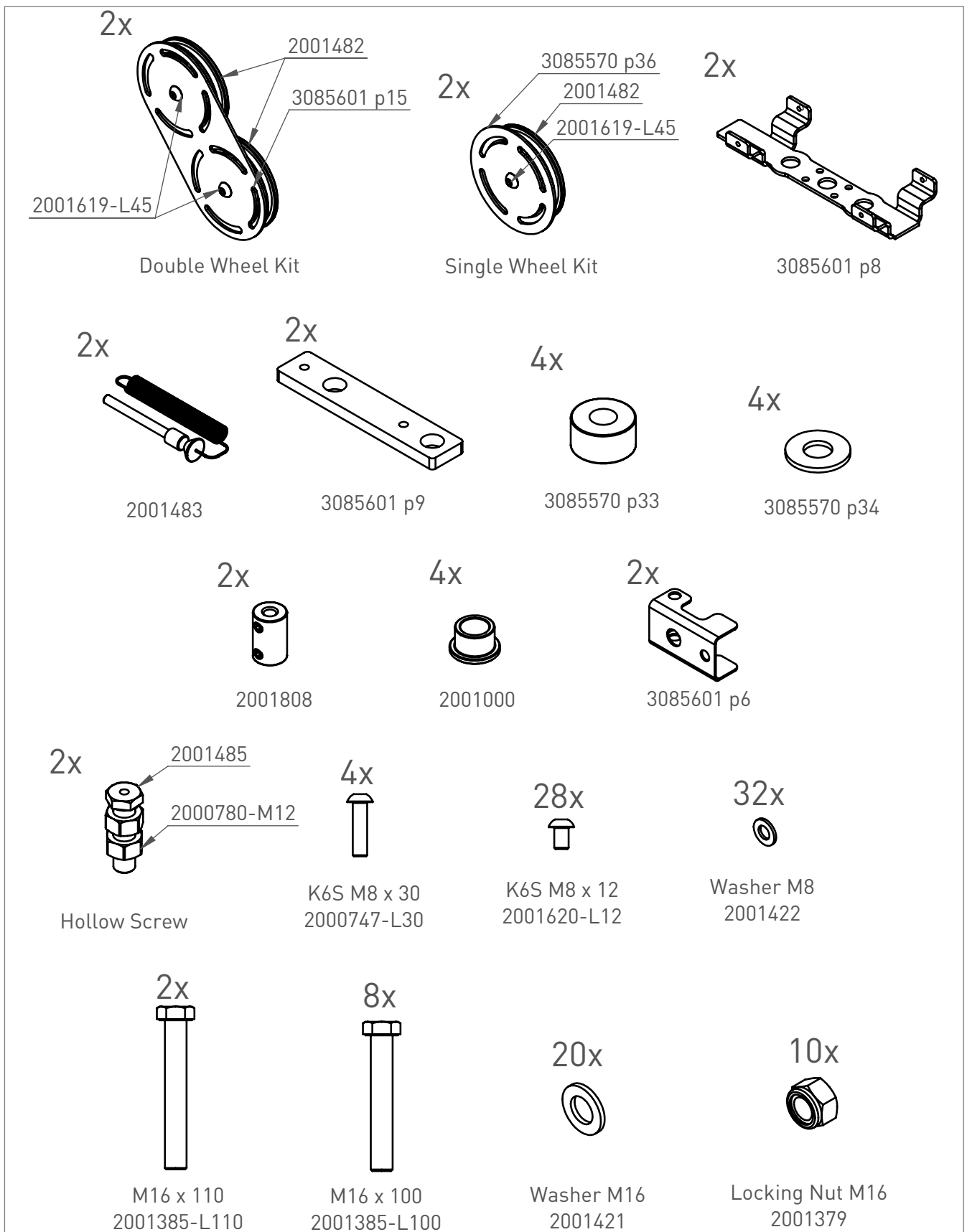



# ASSEMBLY INSTRUCTIONS

Before assembly, make sure you have enough clearance on all sides of the equipment, not less than 0,6 meters. Take in account the accessibility to remove and replace bar and weights.

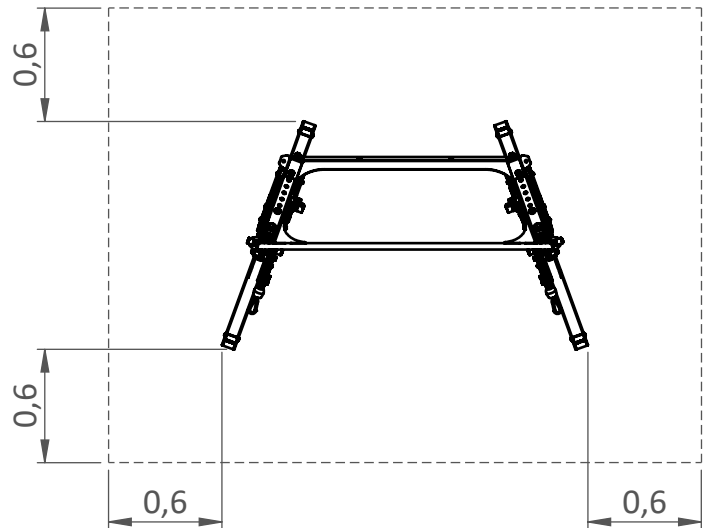

## TOOLS NEEDED

You need the following tools to assemble the equipment.

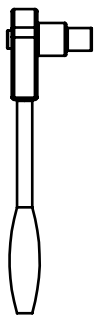

Socket Wrench Size 24mm



Wrench Size 24mm



Wrench Size 17mm

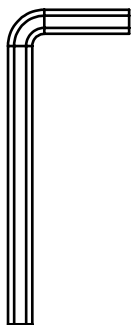

Allen Key Size 8

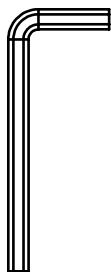

Allen Key Size 6

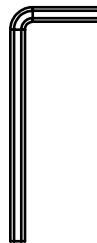

Allen Key Size 5



Allen Key Size 4

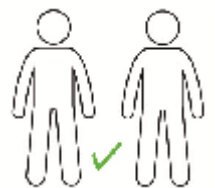

NOTE: Do not use electric power tools for assembly.

# BOLT TO GROUND

Eleiko recommends that this product should be bolted to the ground. Make sure the ground is solid and level. Consult a licensed contractor to choose the appropriate anchoring fasteners for your facility.

See assembly instructions for the position of the anchoring points.

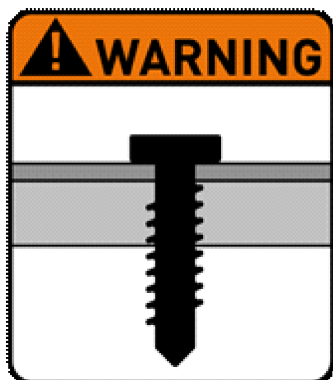

1.

1x



2001845

1x

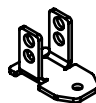

2001373

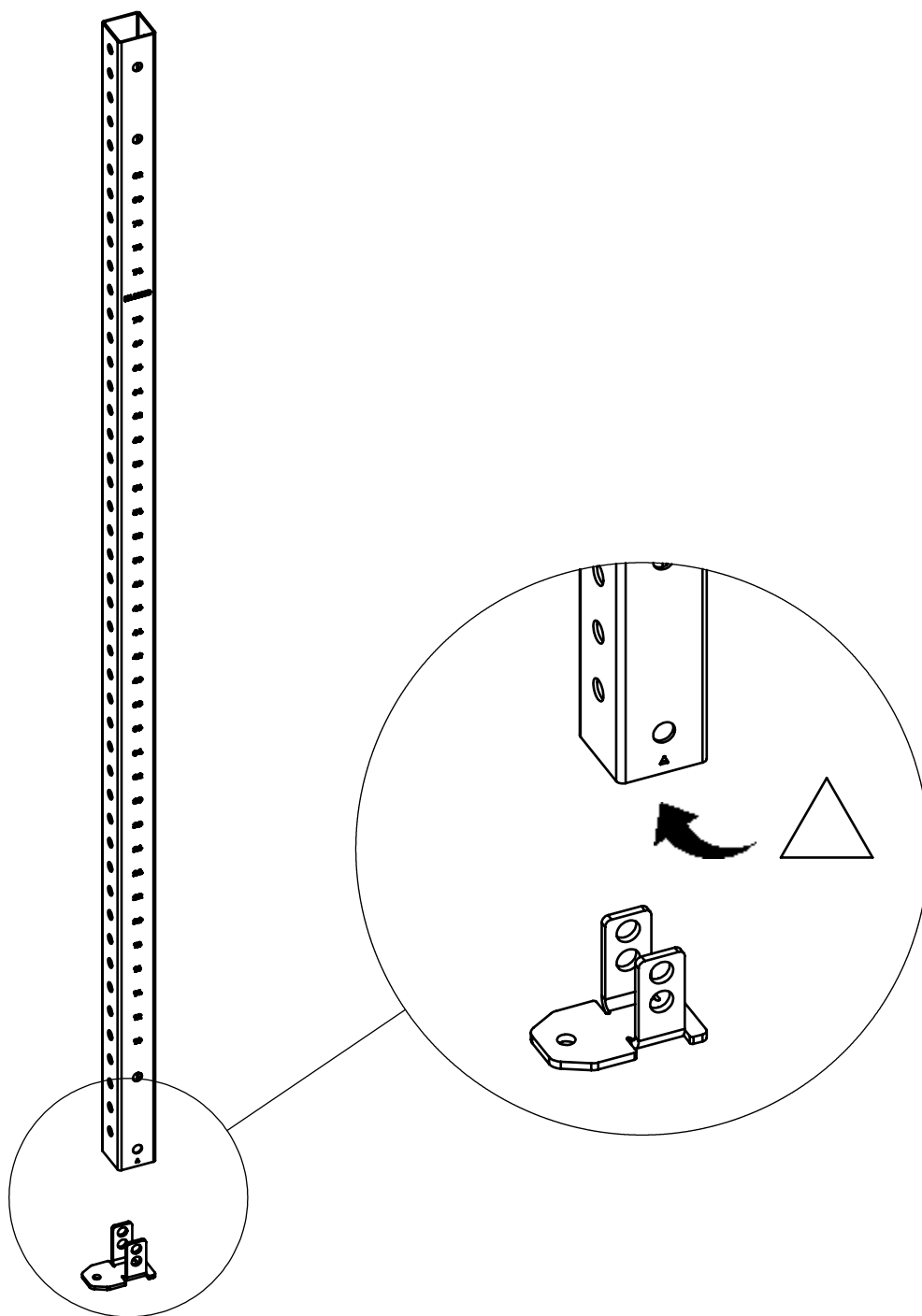

2.

1x

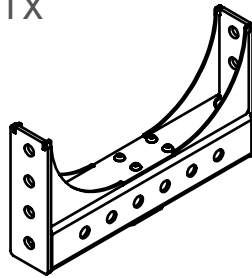

2001592

Remove screws and plate from floor beam!  
You will not need these parts!

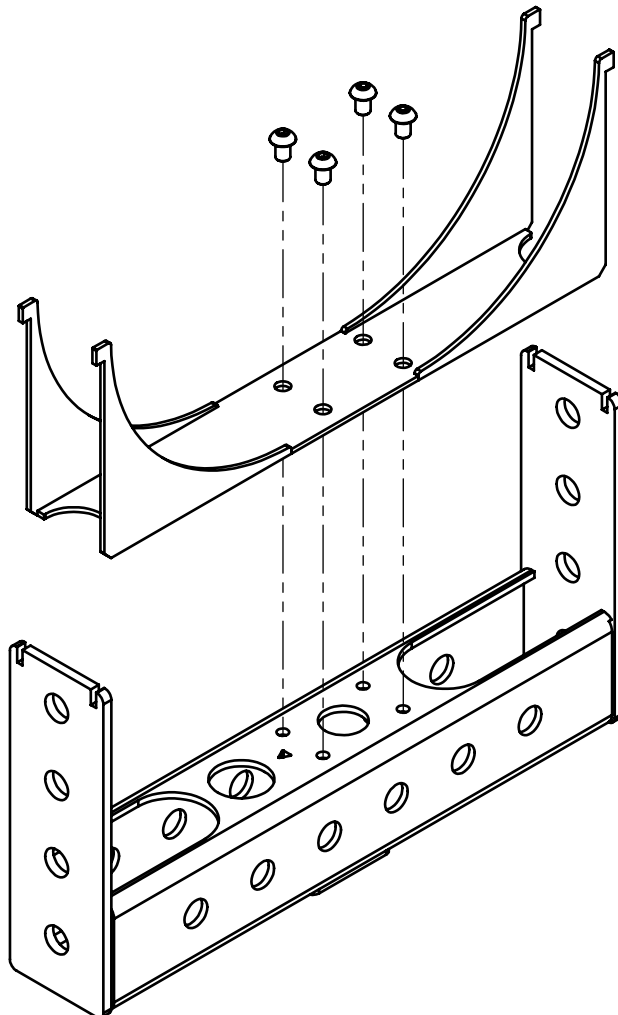

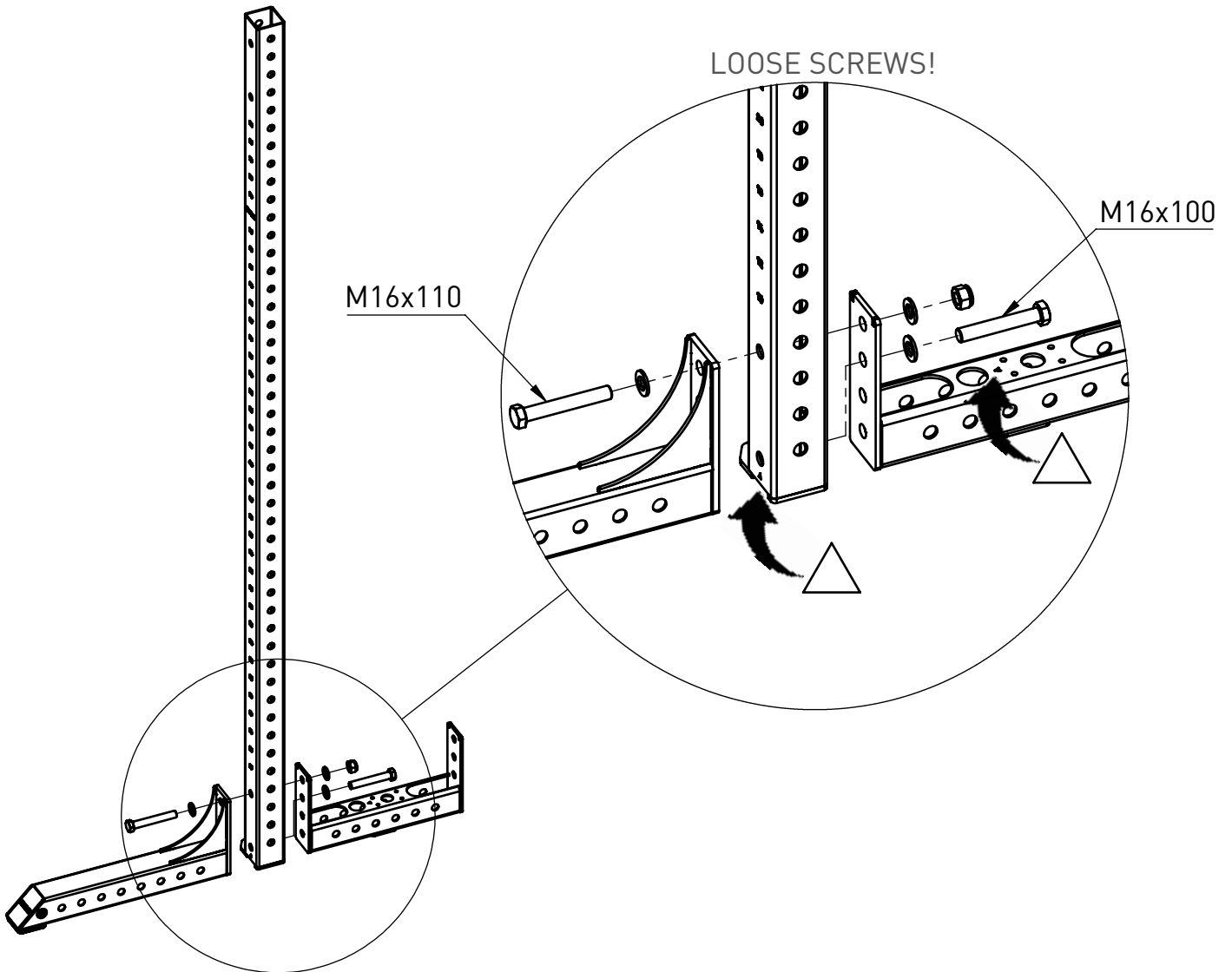
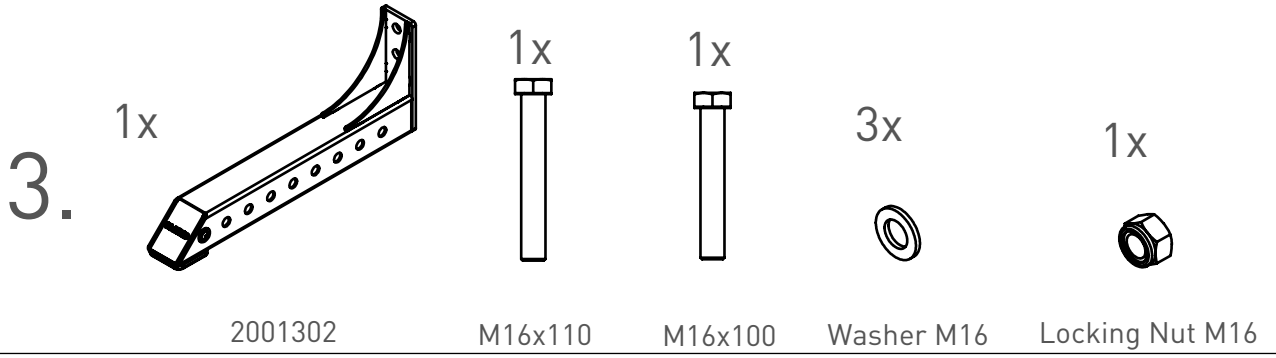

4.

1x



2001320

1x

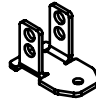

2001373

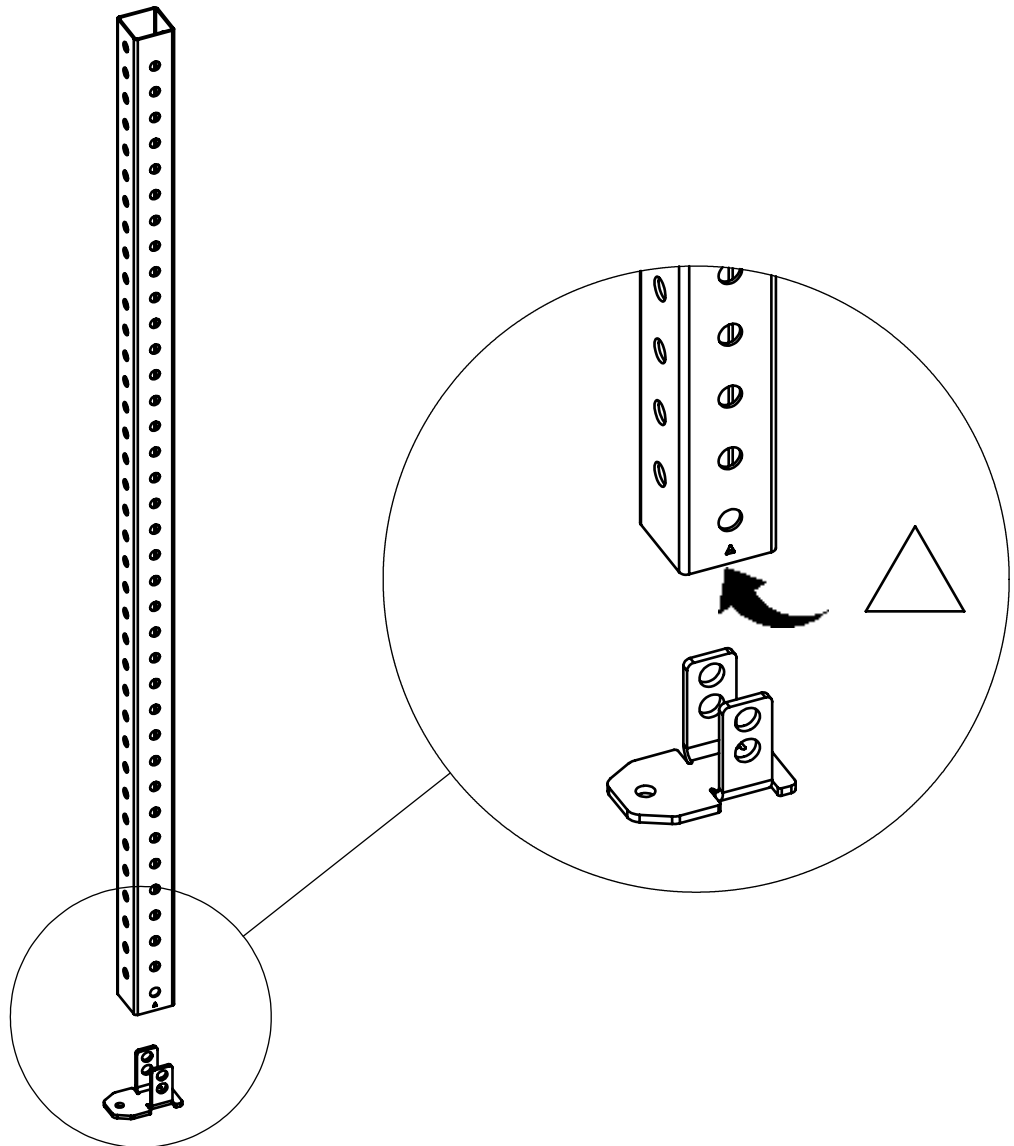

5.

1x

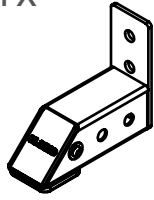

2001859

1x

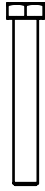

M16x110

1x

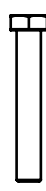

M16x100

3x



Washer M16

1x



Locking Nut M16

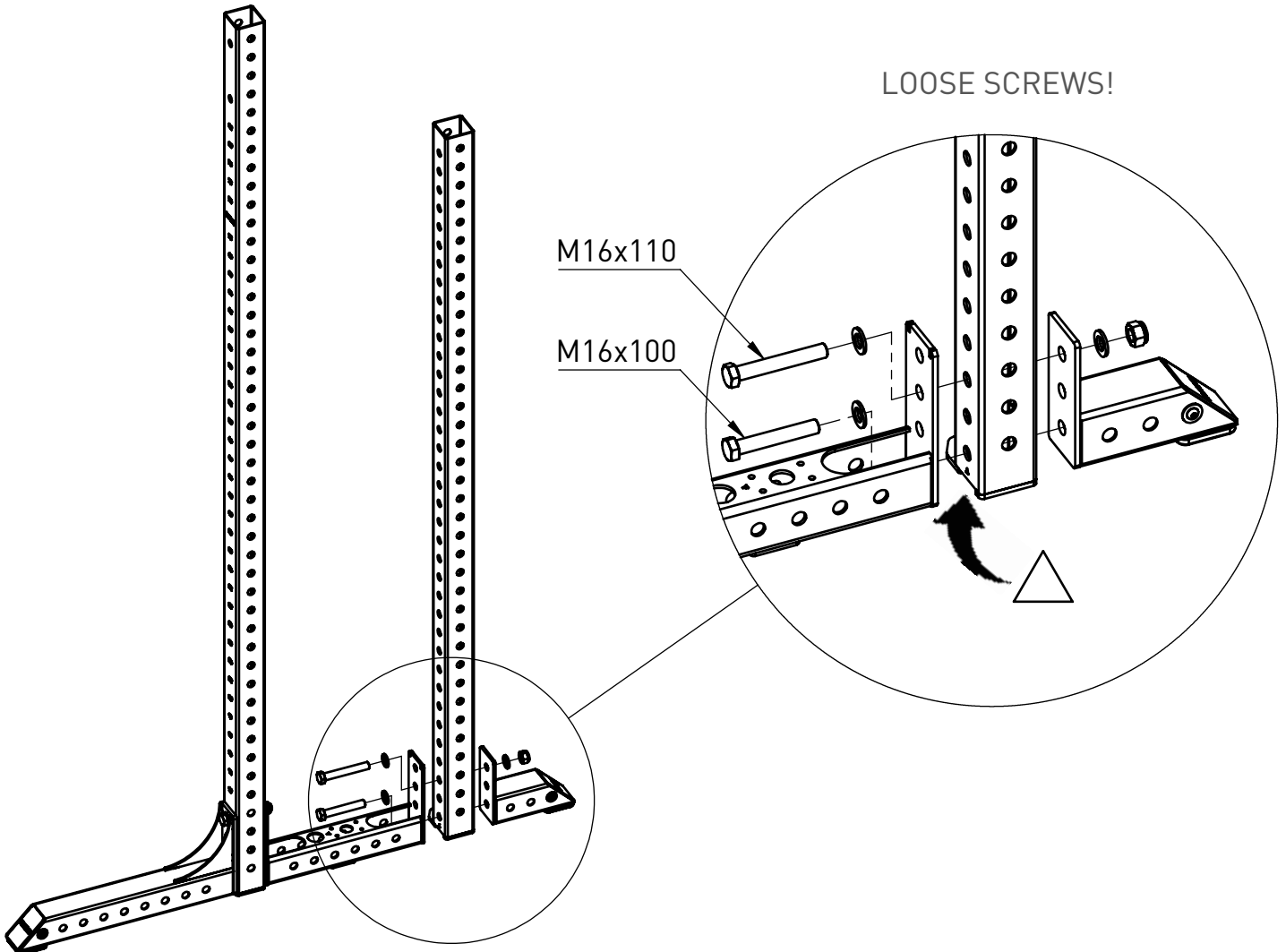

6.

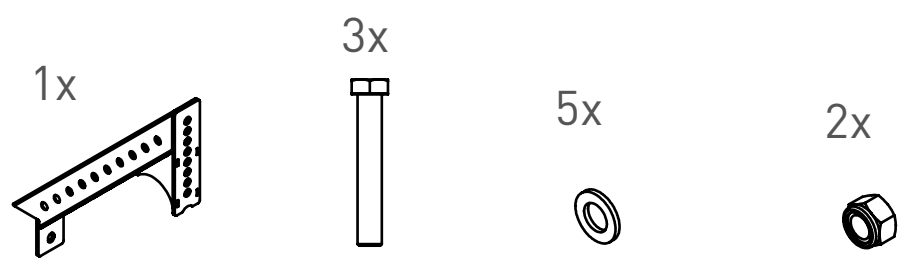

LOOSE SCREWS!

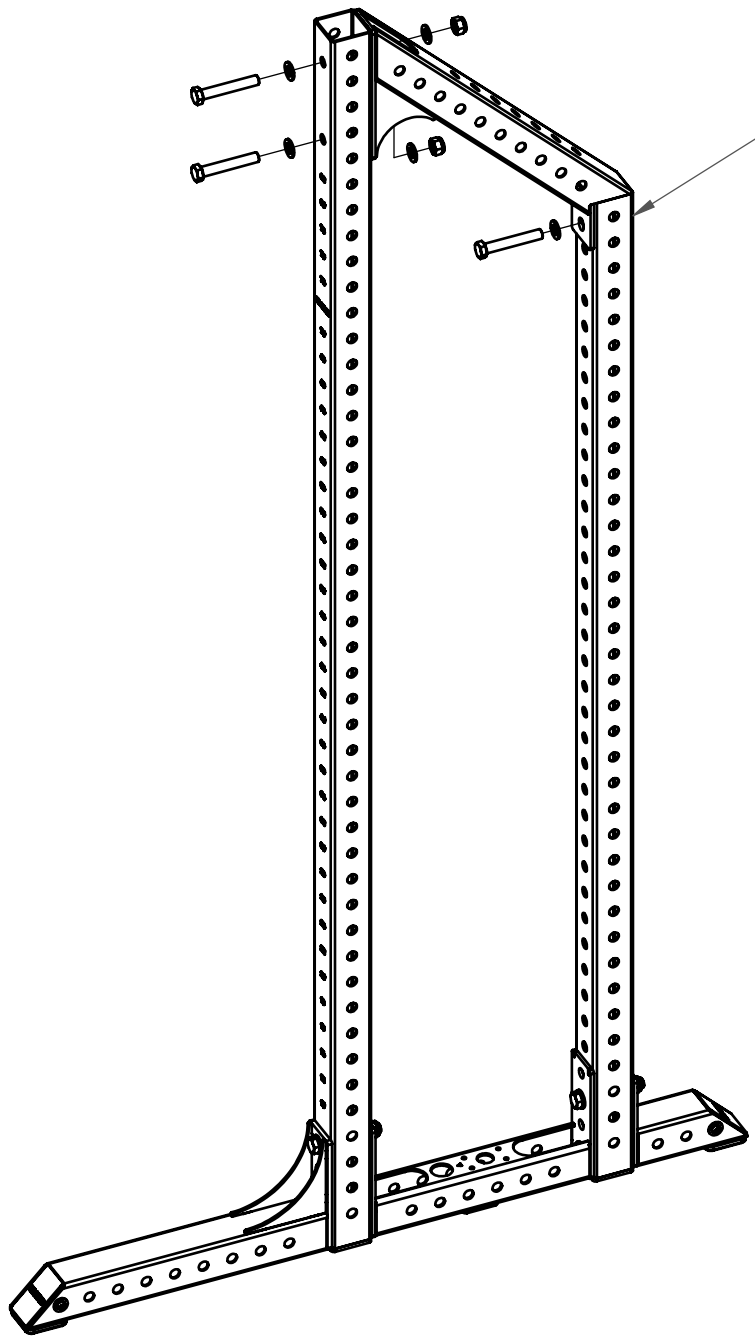

This locking nut and washer will be mounted later!



7.

1x

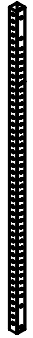

2001845

1x

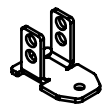

2001373

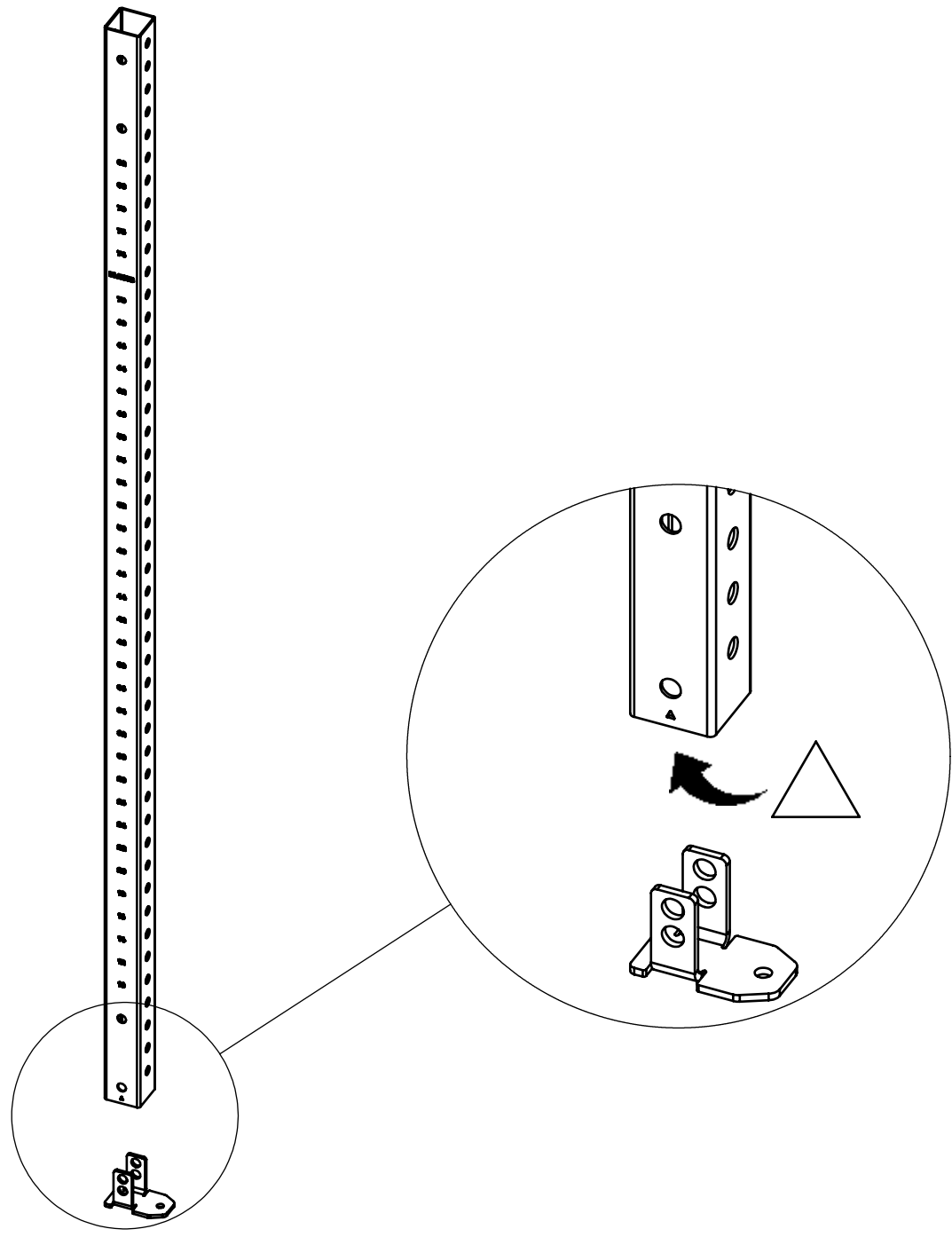

8.

1x

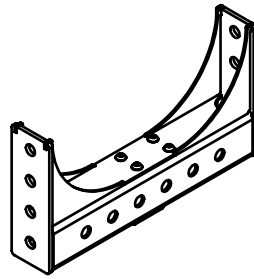

2001592

Remove screws and plate from floor beam!  
You will not need these parts!

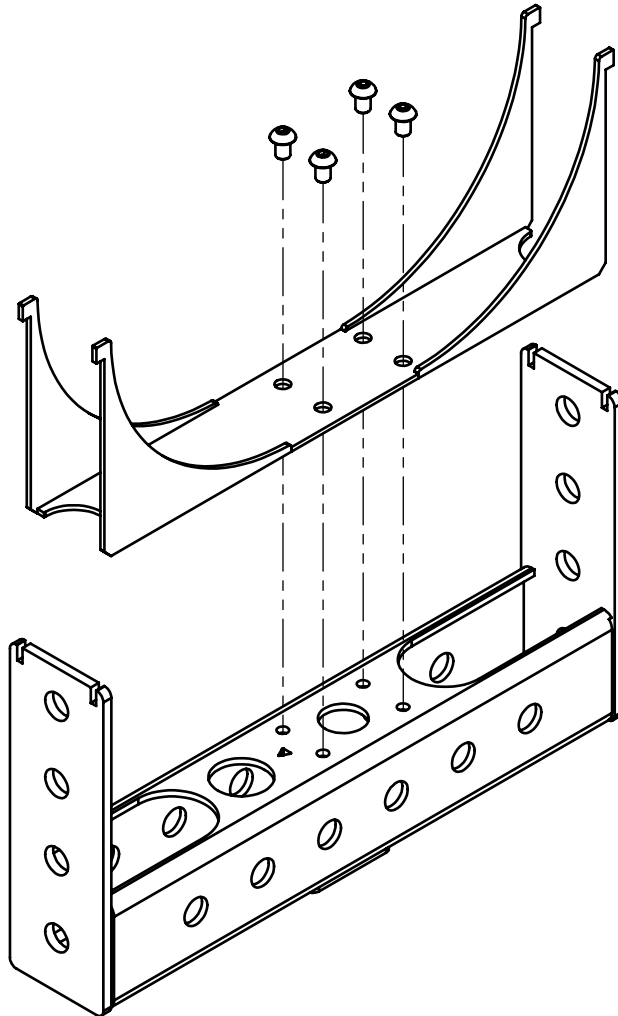

9.

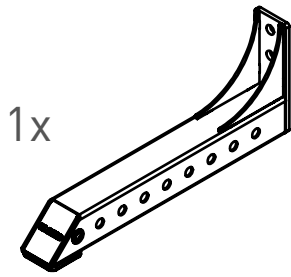

1x

2001302



1x

M16x110

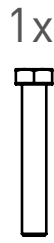

1x

M16x100

3x



Washer M16

1x



Locking Nut M16

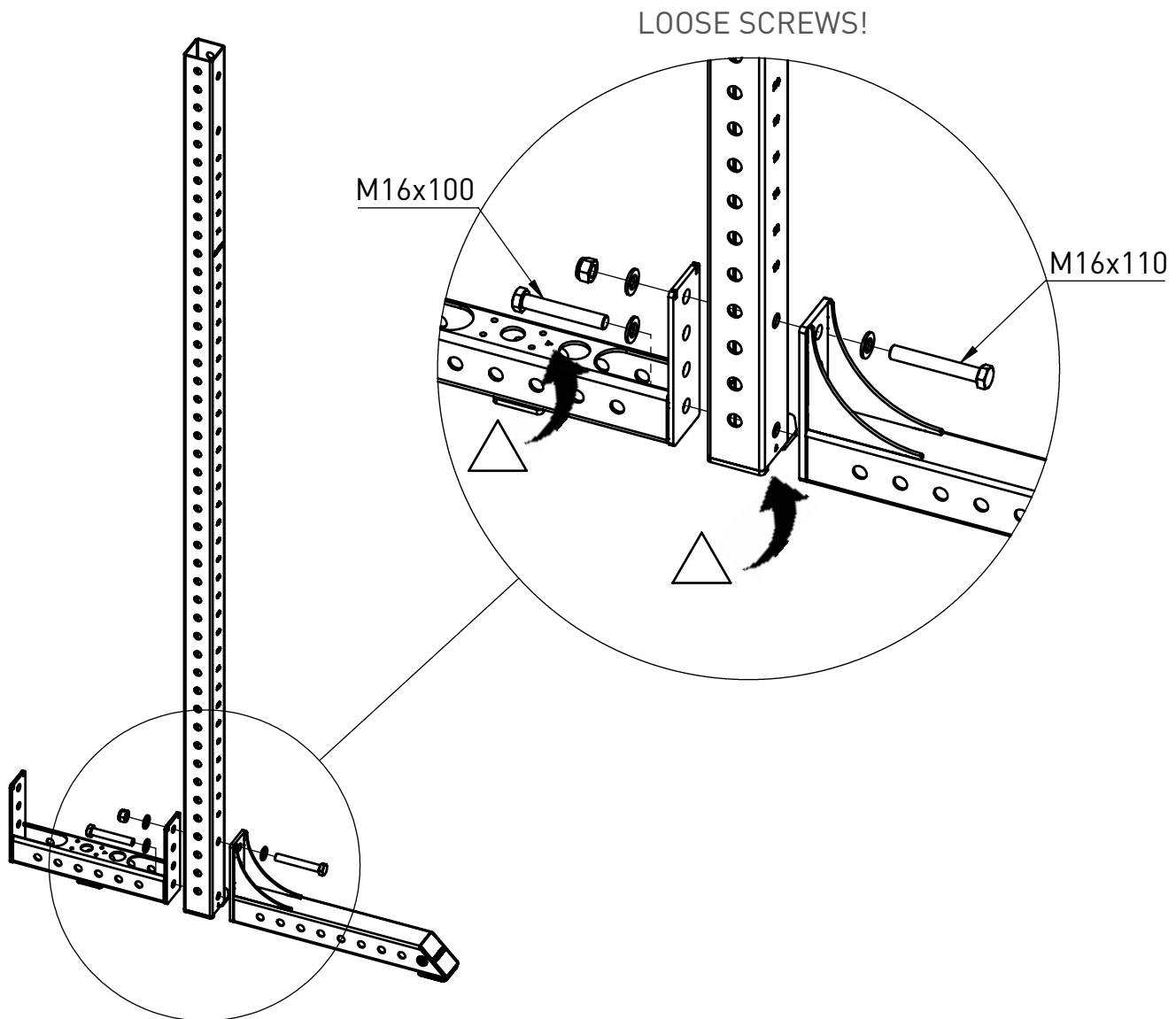

10.

1x



2001320

1x

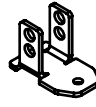

2001373

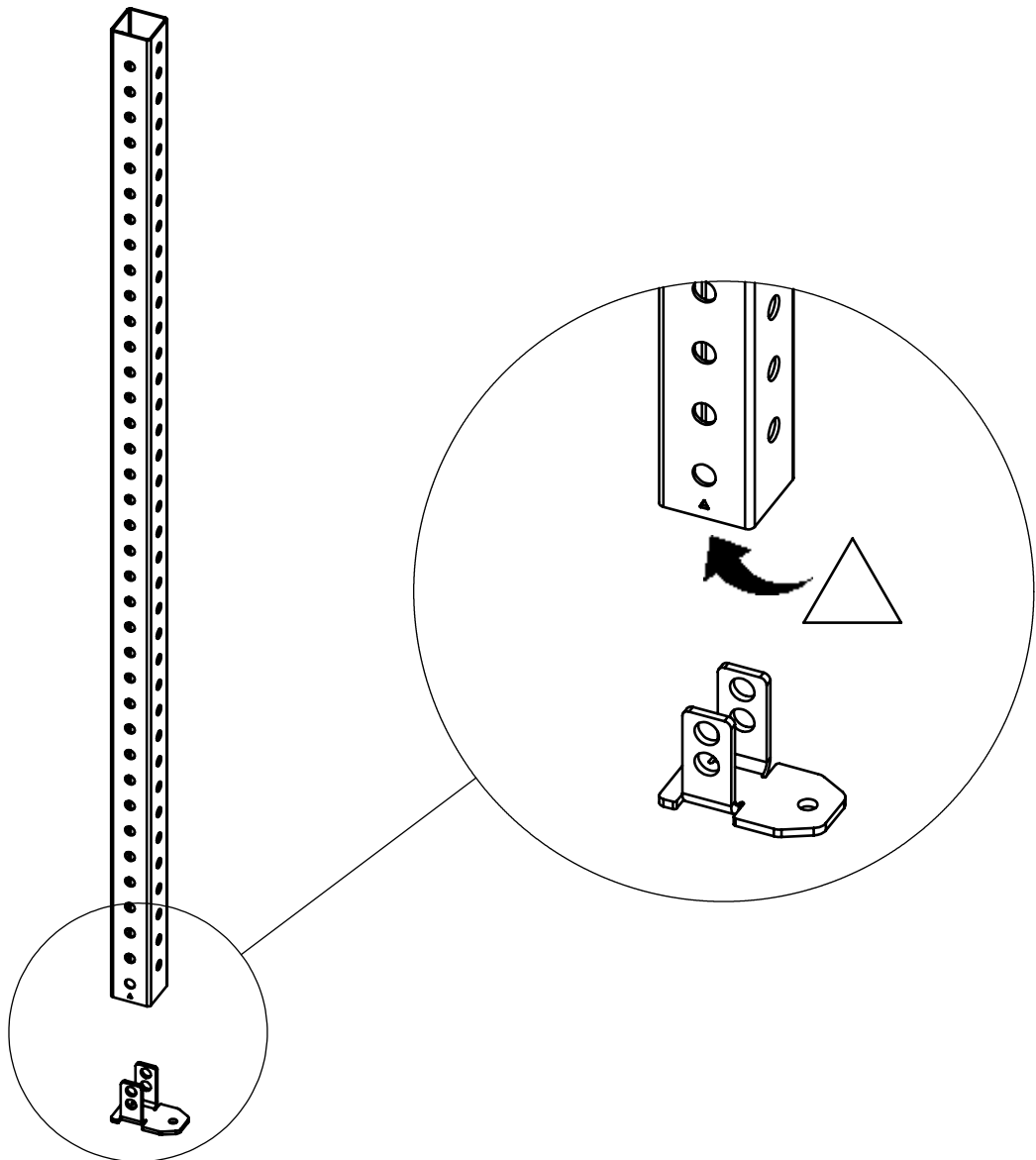

11.

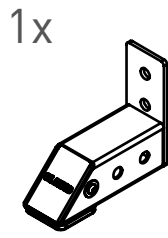

2001859

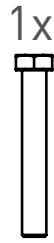

M16x110

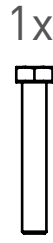

M16x100



Washer M16



Locking Nut M16

LOOSE SCREWS!

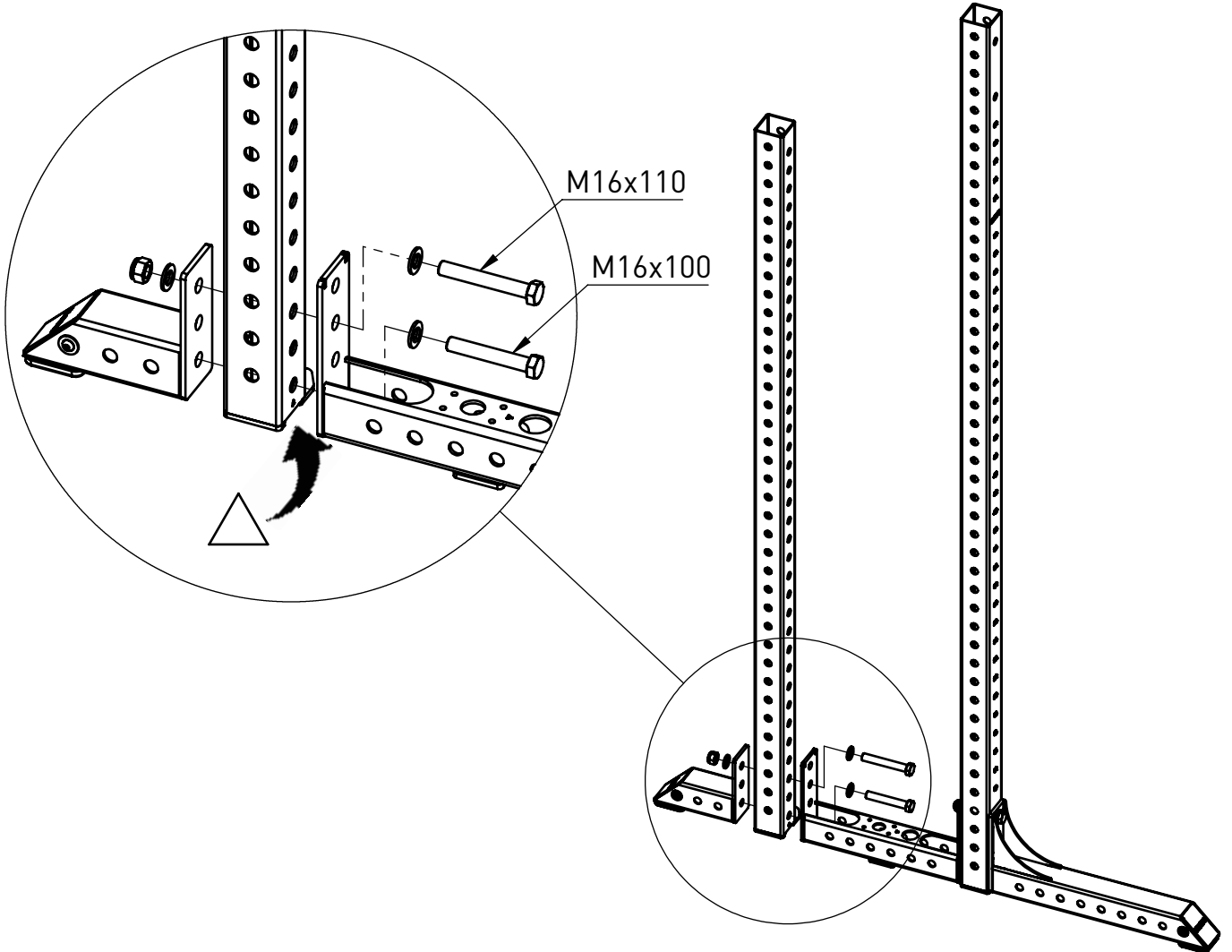

12.

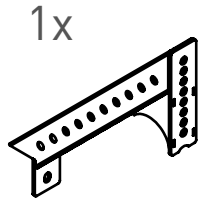

2001299

3x



M16x100

5x



Washer M16

2x



Locking Nut M16

LOOSE SCREWS!

This locking nut and washer  
will be mounted later!

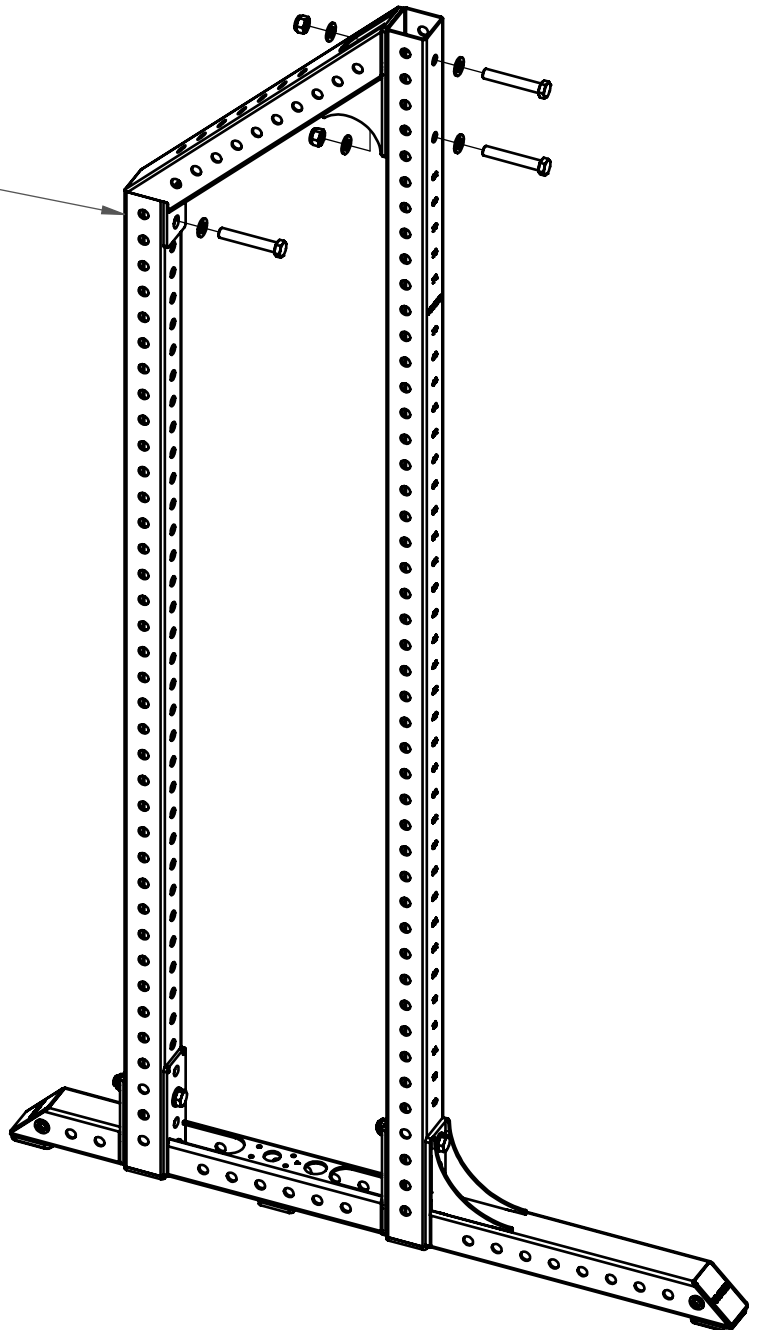

13.

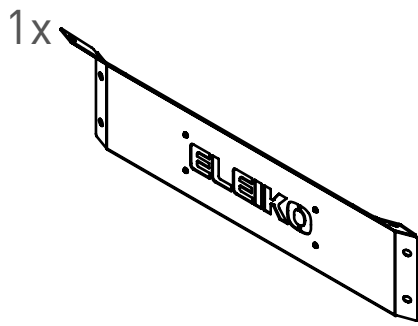

3085806a1

2x

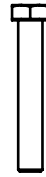

M16x100

6x



Washer M16

4x



Locking Nut M16

LOOSE SCREWS!

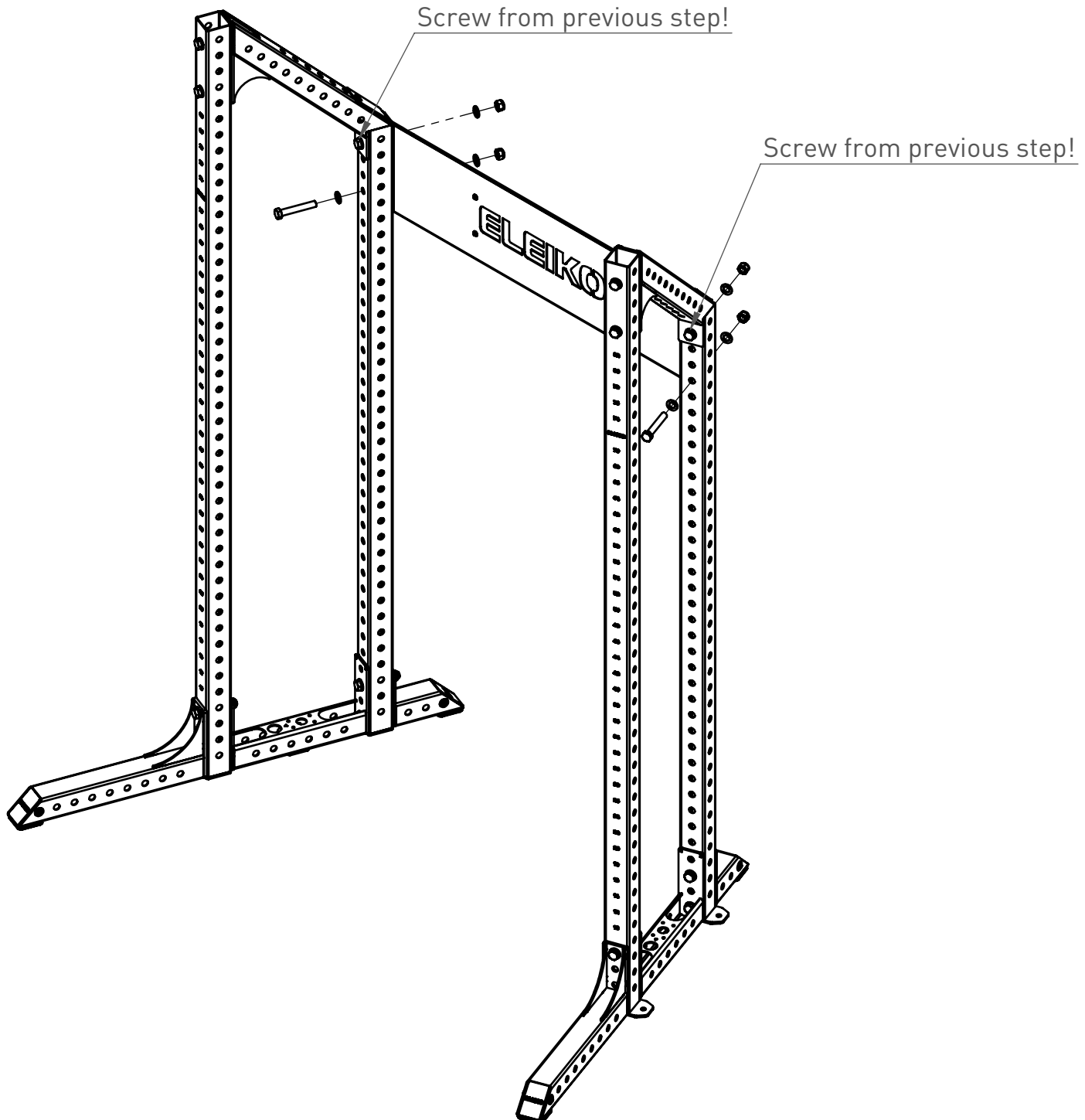

14.

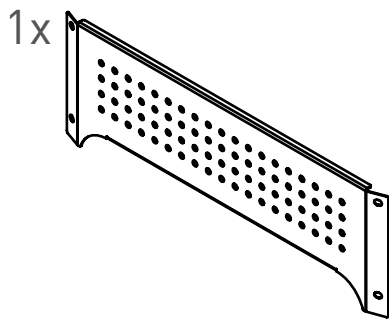

3085806p6

4x

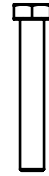

M16x100

8x



Washer M16

4x



Locking Nut M16

LOOSE SCREWS!

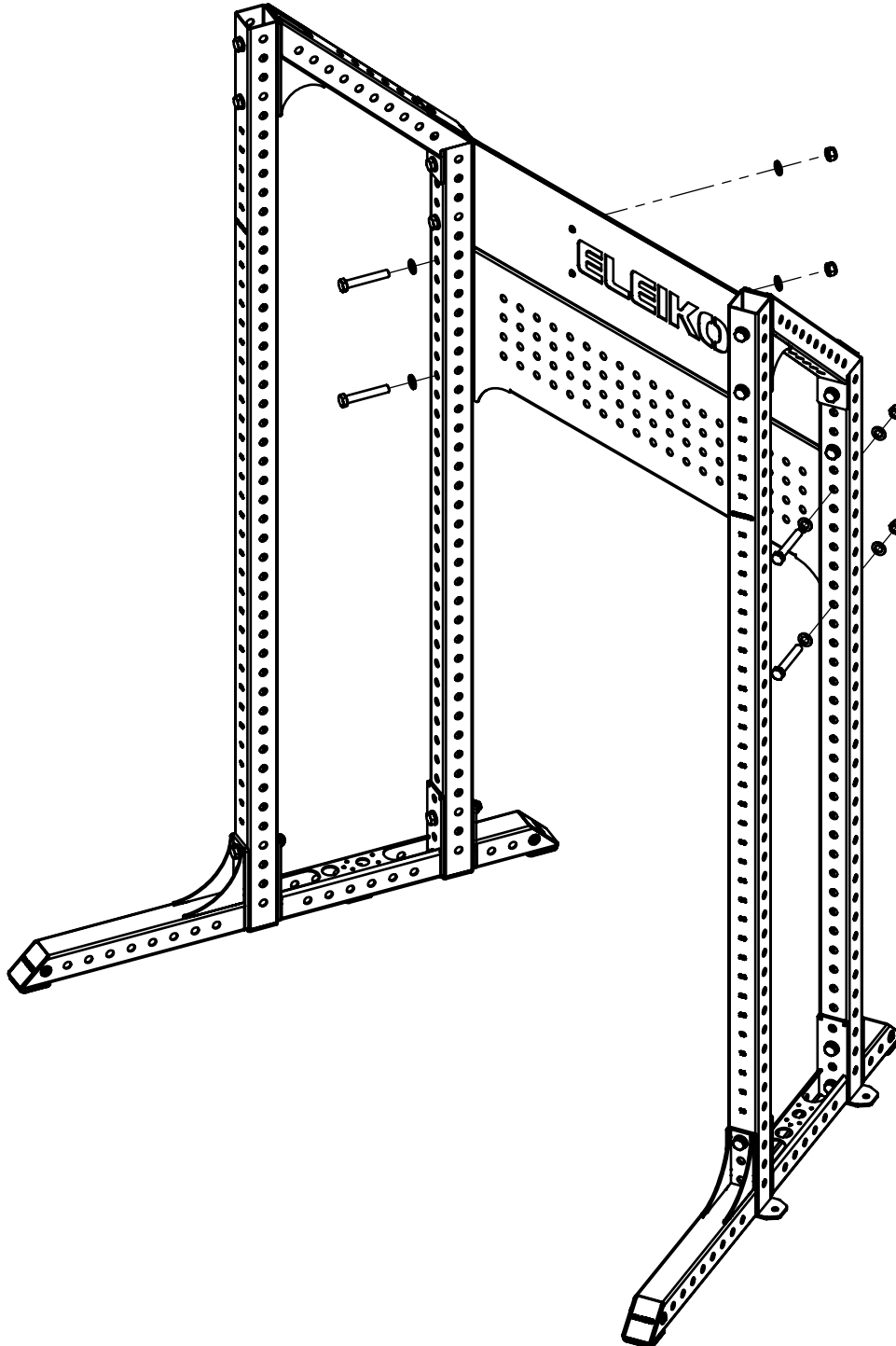



15.

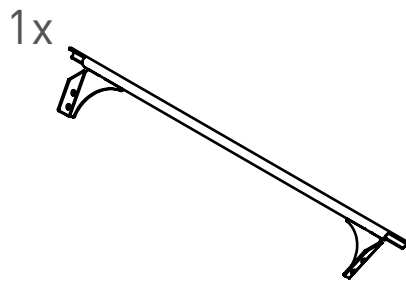

2001860a1

4x

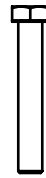

M16x100

8x



Washer M16

4x



Locking Nut M16

If you have purchased Eleiko DAP Storage Shelf Adapter and Eleiko Prestera Storage Shelves. Install them before you tighten all screws!

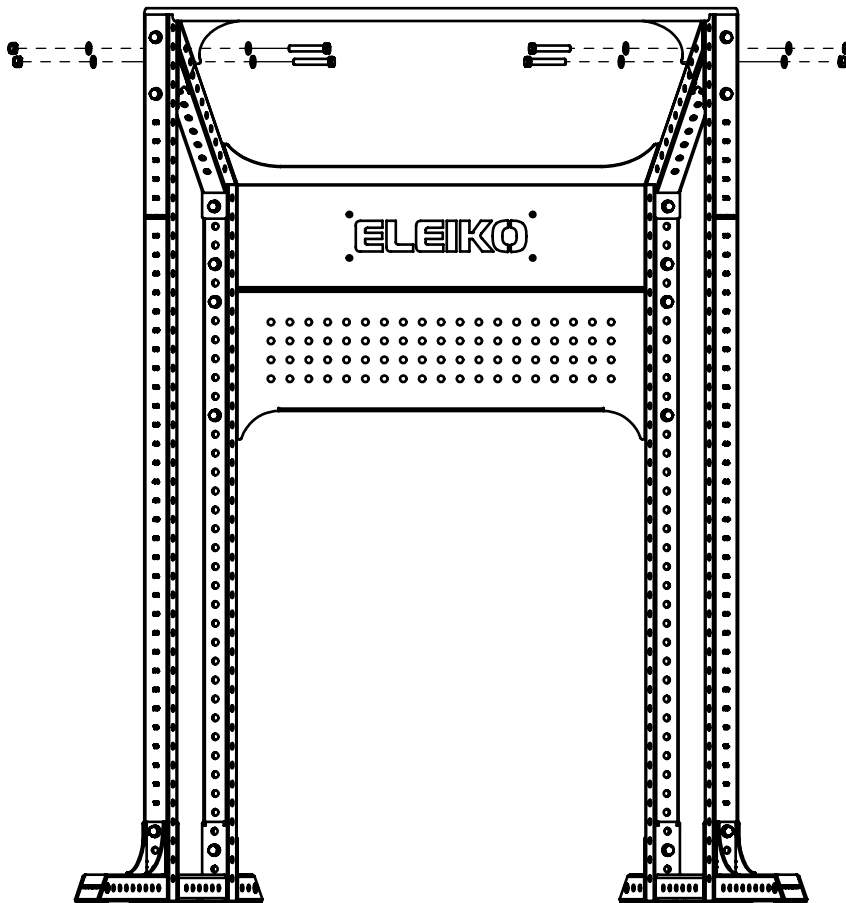

Carefully shake the rack so that all screws falls into the correct position before tightening all screws!

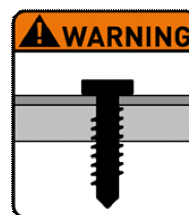
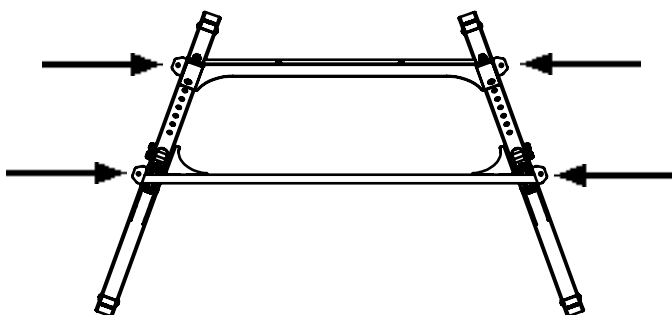

16.

1x

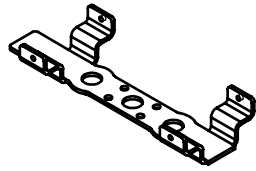

3085601 p8

4x



K6S M8 x 12

4x



Washer M8

Start with left side!

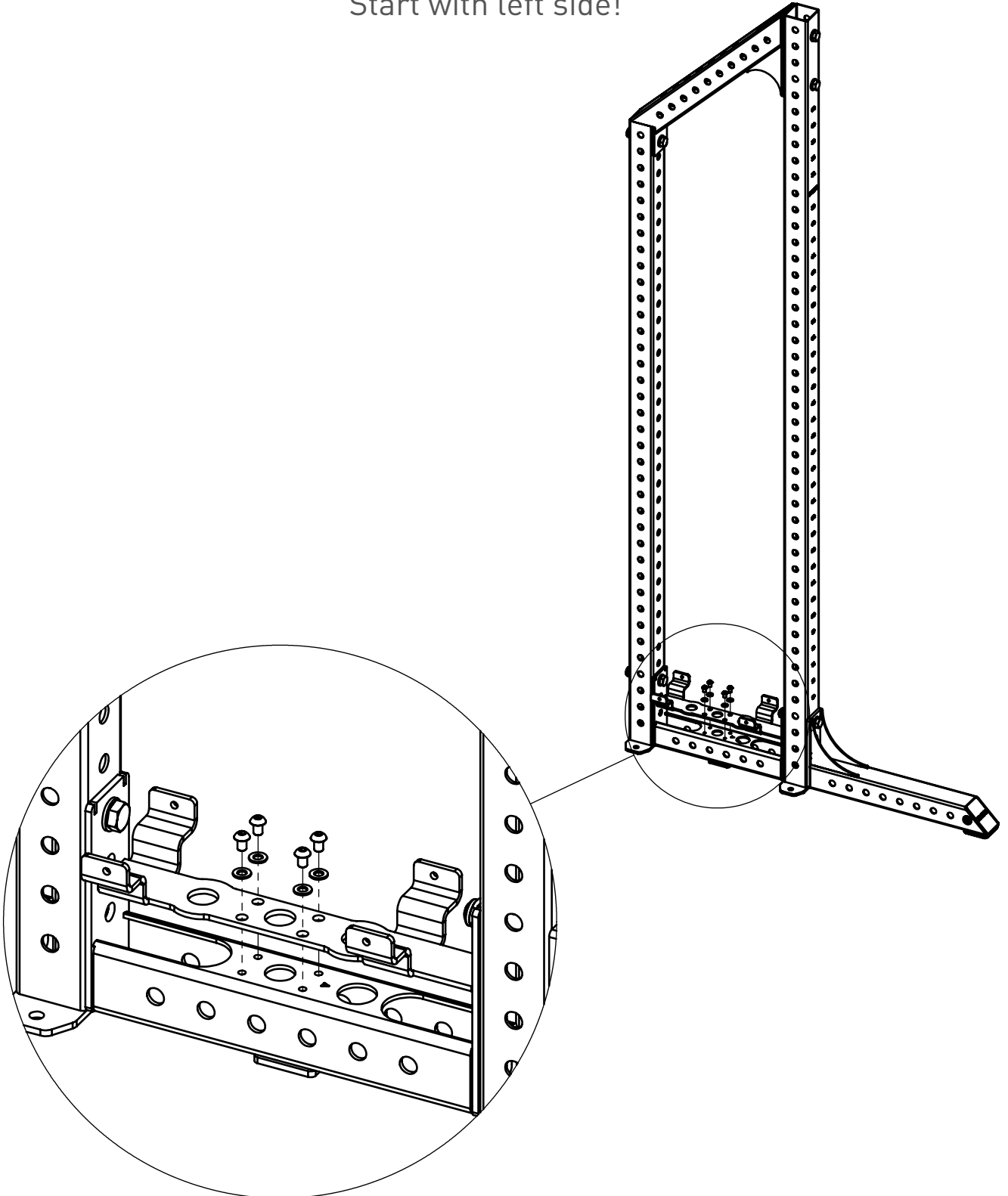

17.

1x

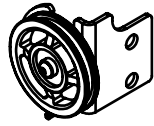

3085601 a8

2x

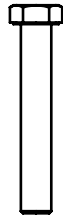

M16 x 100

4x



Washer M16

2x



Locking Nut M16

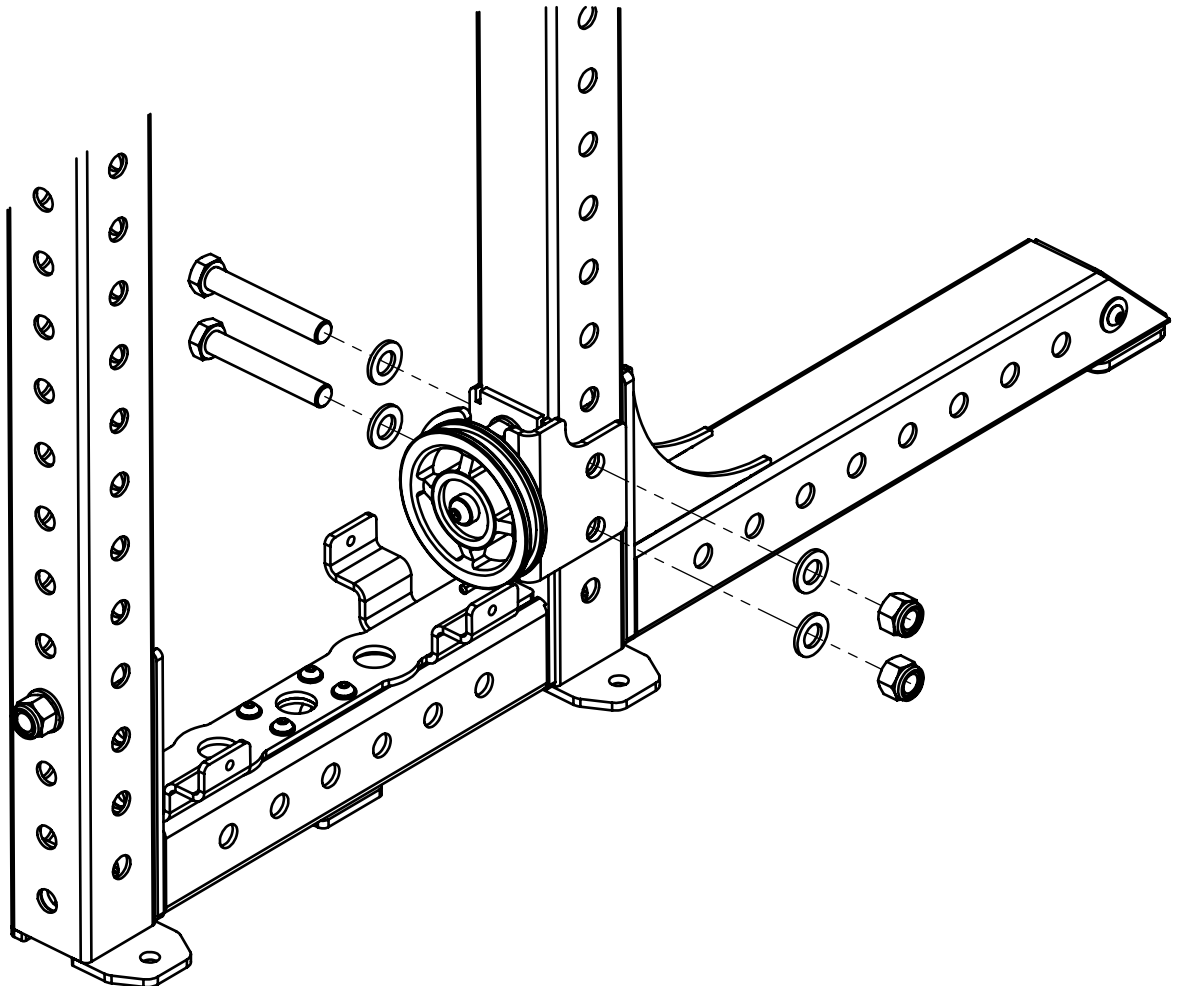

18.

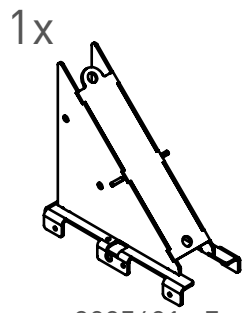

3085601 a7

2x

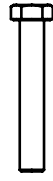

M16 x 100

4x



Washer M16

2x



Locking Nut M16

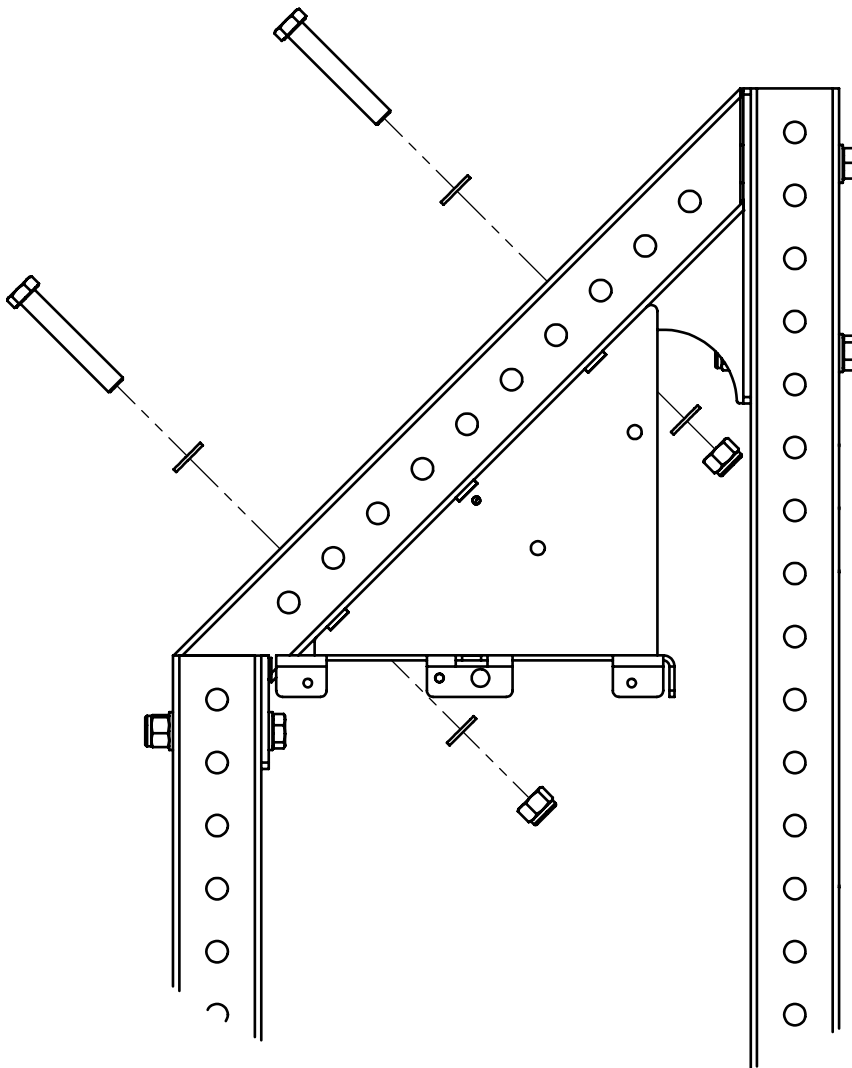

19.

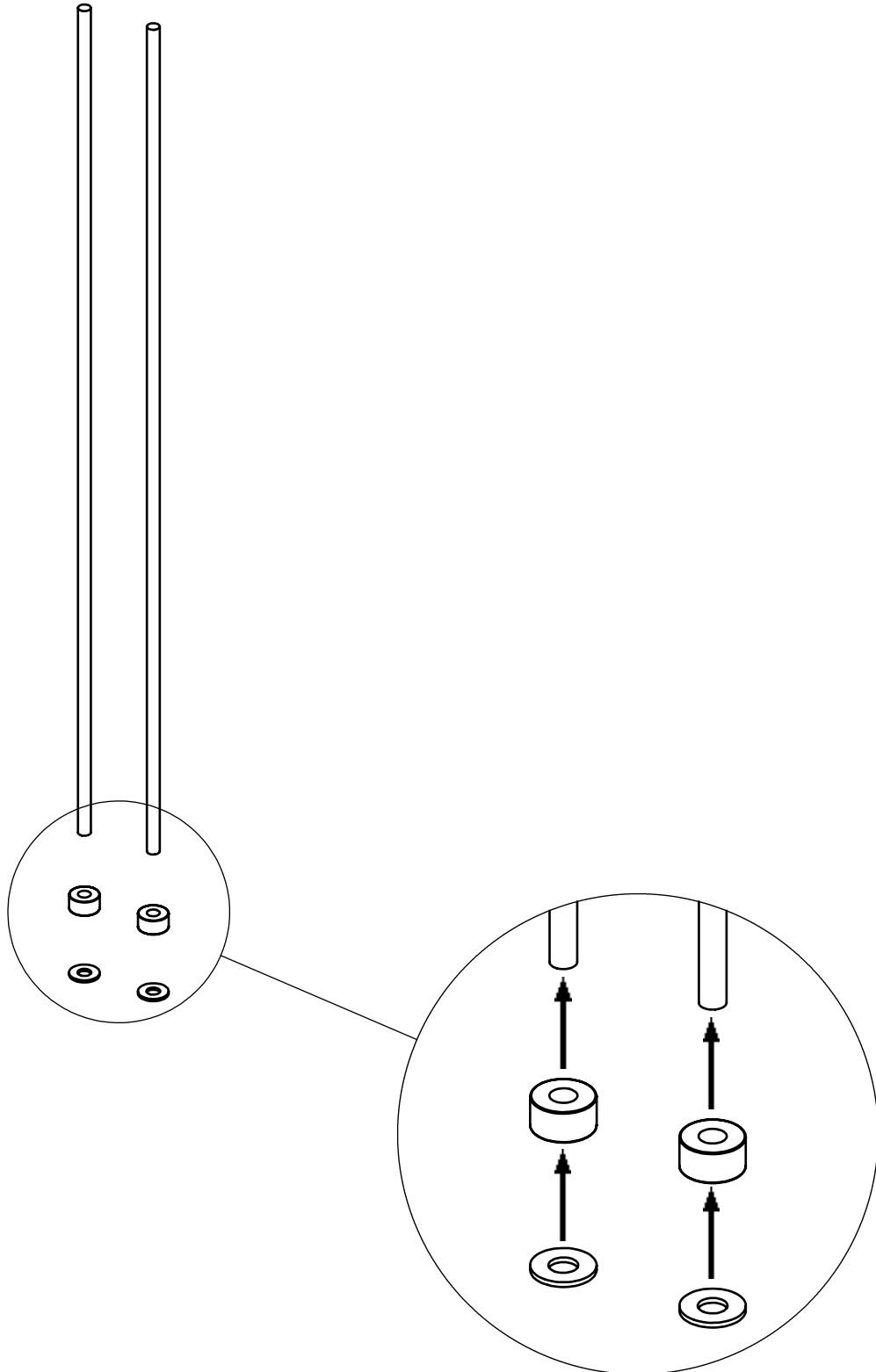
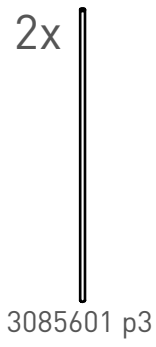

# 20.

Place rods in tilted position in these holes.  
Rubber dampers and distance plates down!

Wipe off both rods with a clean cloth!

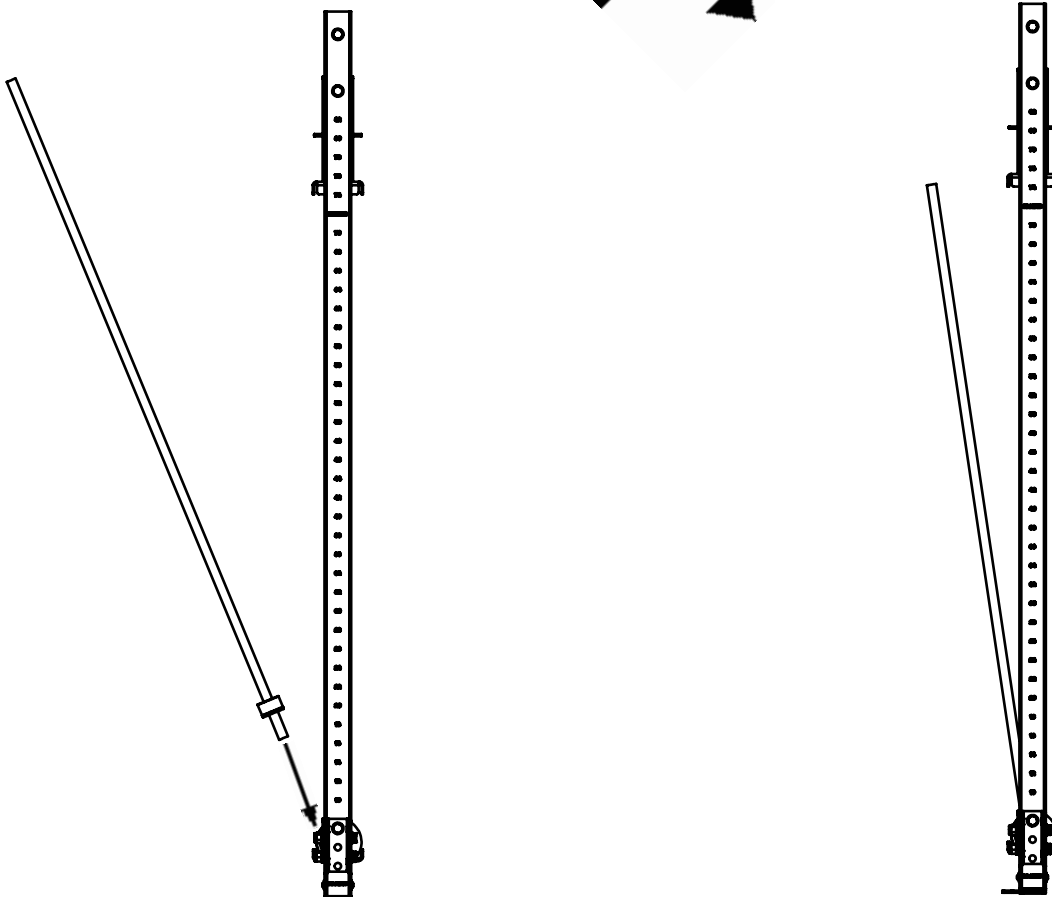
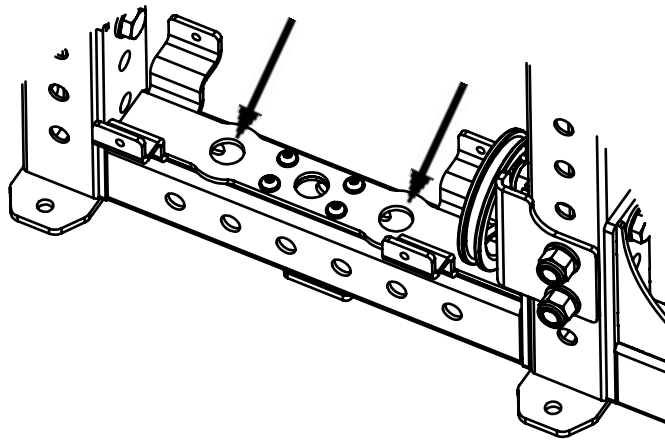

19X (120 kg) / 14X (90 kg)

21.

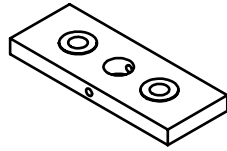

2001590

Assemble the weight stack plate by plate!

Make sure the first plate is pushed all the way down and locked in position!

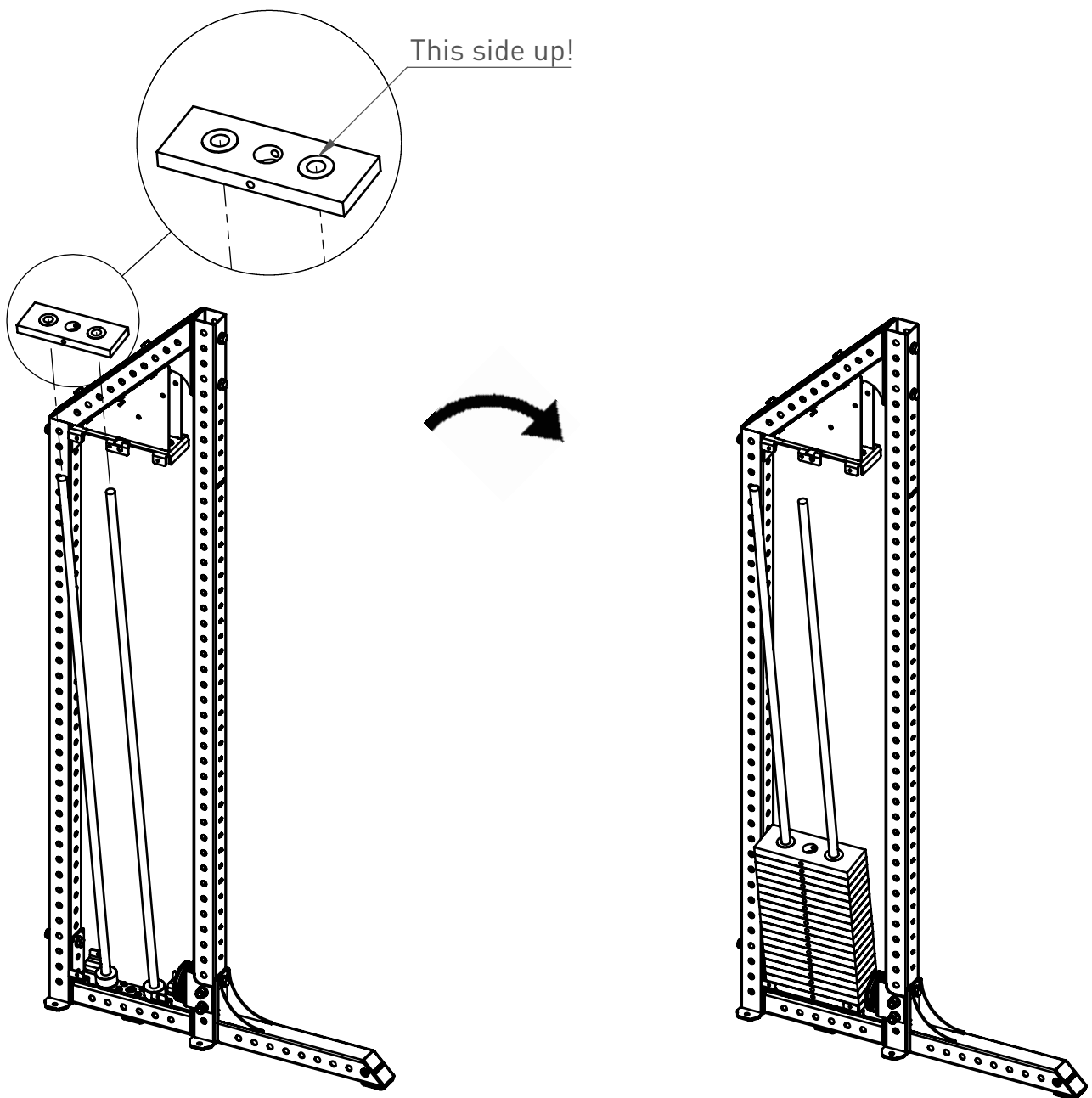

22.

1x

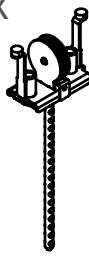

3085601 a1 / 3085850 a1

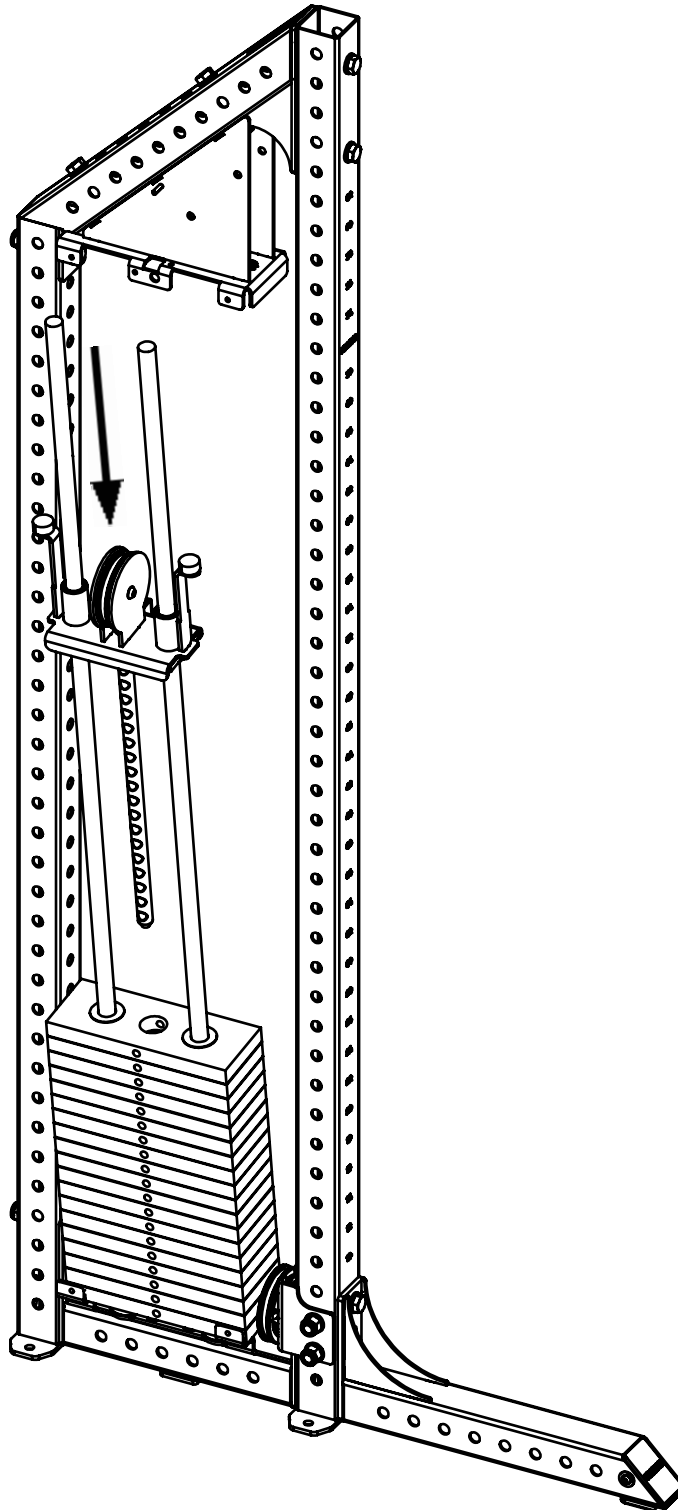



23.

1x

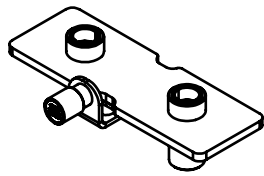

3085601 a2

1x

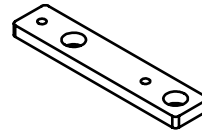

3085601 p9

Mount top weight and plastic top suspension!  
Push to vertical position!

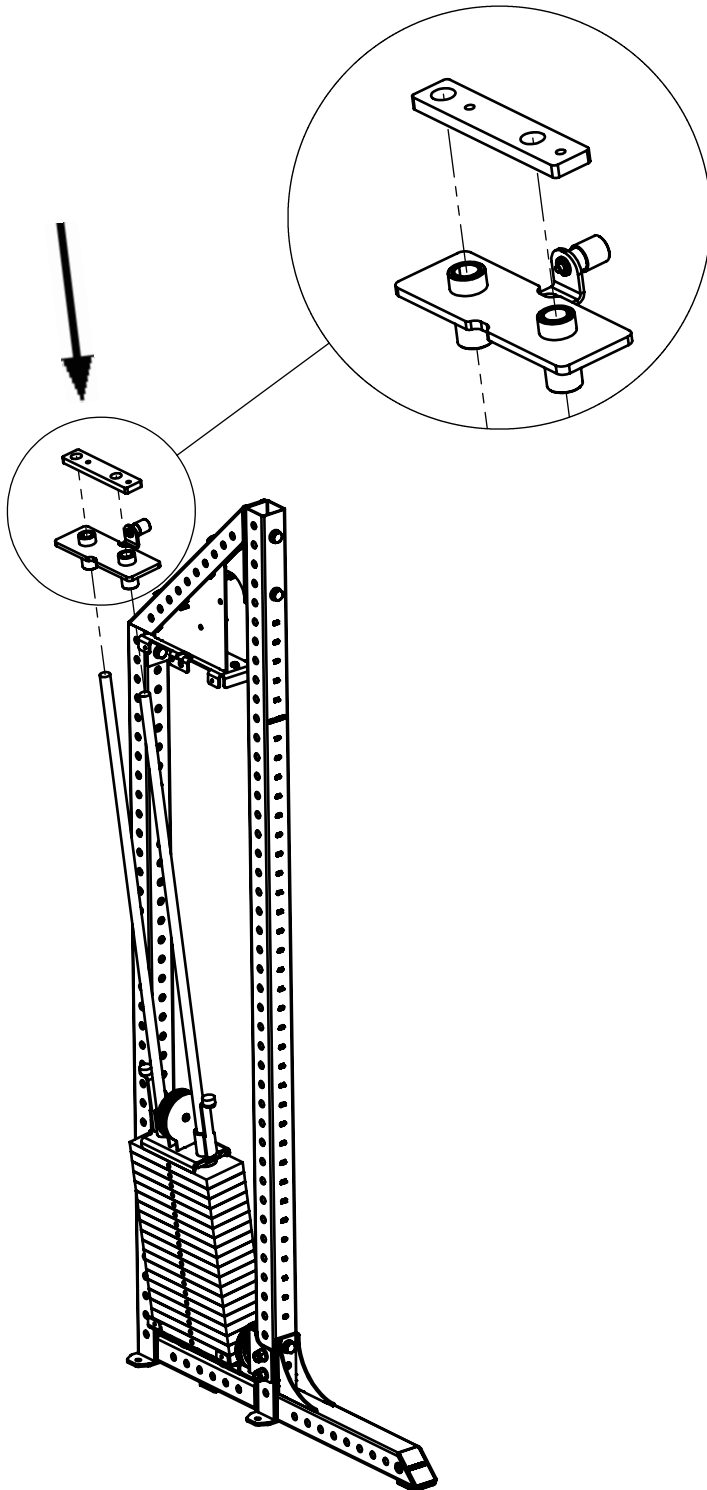

Top weight and plastic top suspension  
must be turned this way!

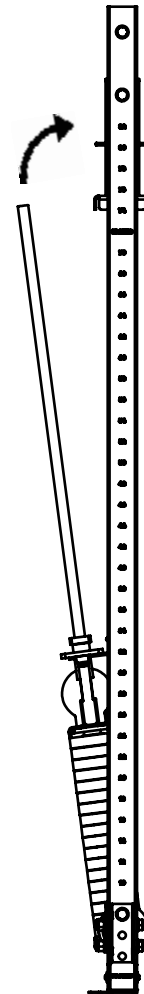

24.

1x

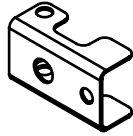

3085601 p6

2x



K6S M8 x 30

2x



K6S M8 x 12

4x



Washer M8

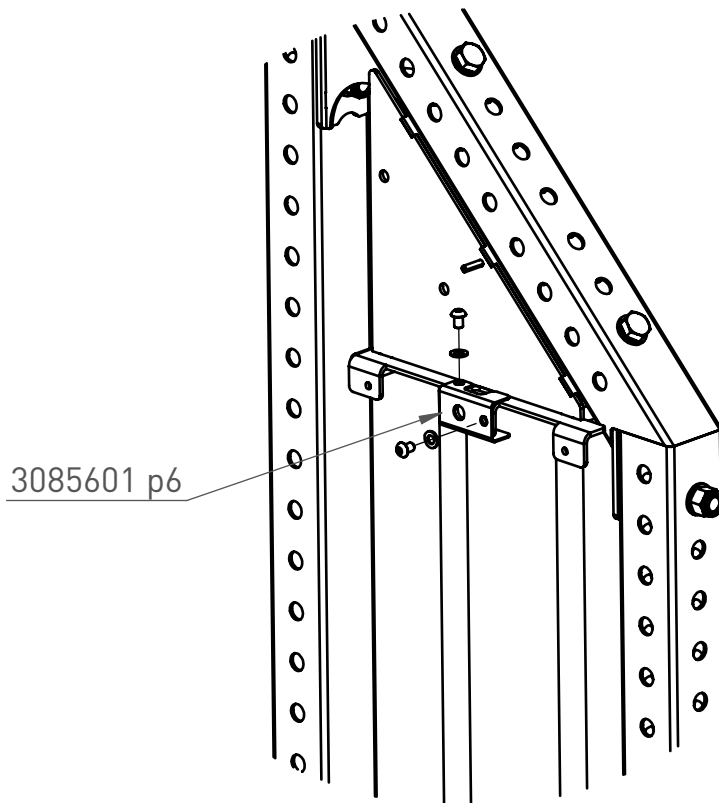
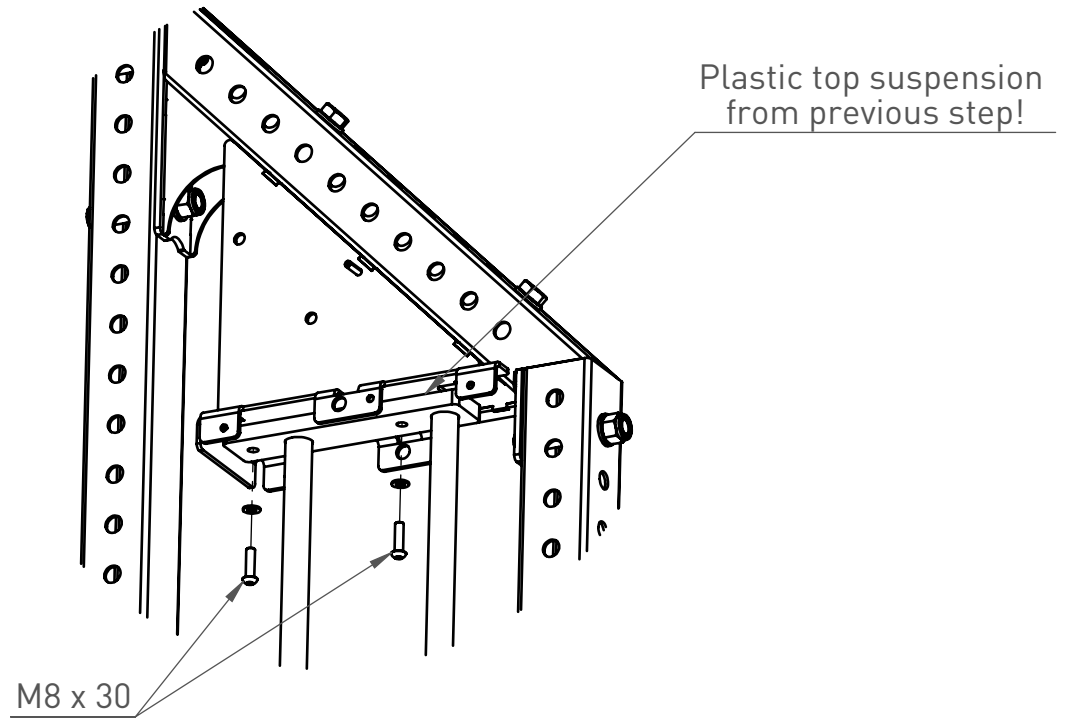

The weight increment can now be secured in a top position with help of the pop-pin!

25.

1x

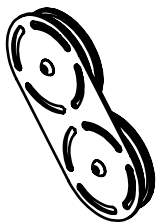

Double Wheel Kit

1x



Single Wheel Kit

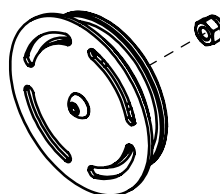
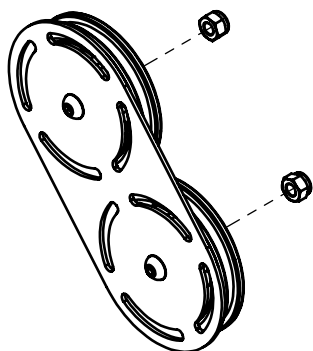

Unscrew nuts and mount both wheel kits!

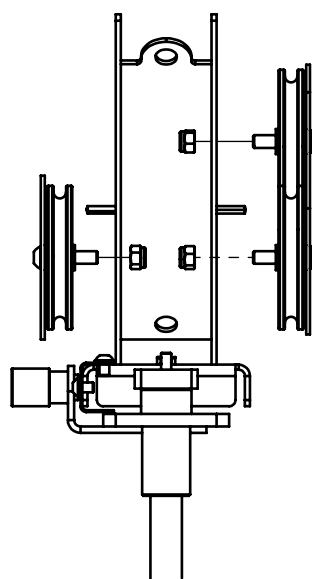
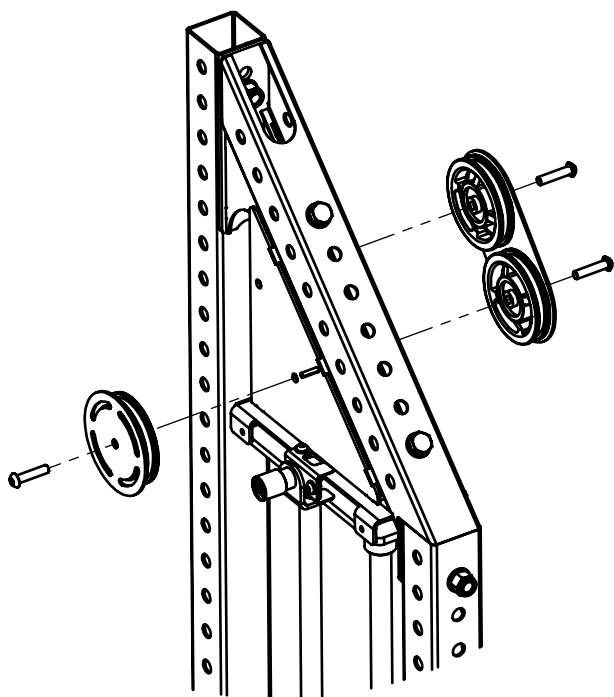

26.

1x



3085601 a9

2x



M16x100

4x



Washer M16

2x



Locking Nut M16

These screws can be found in the screw kit that came with the frame!

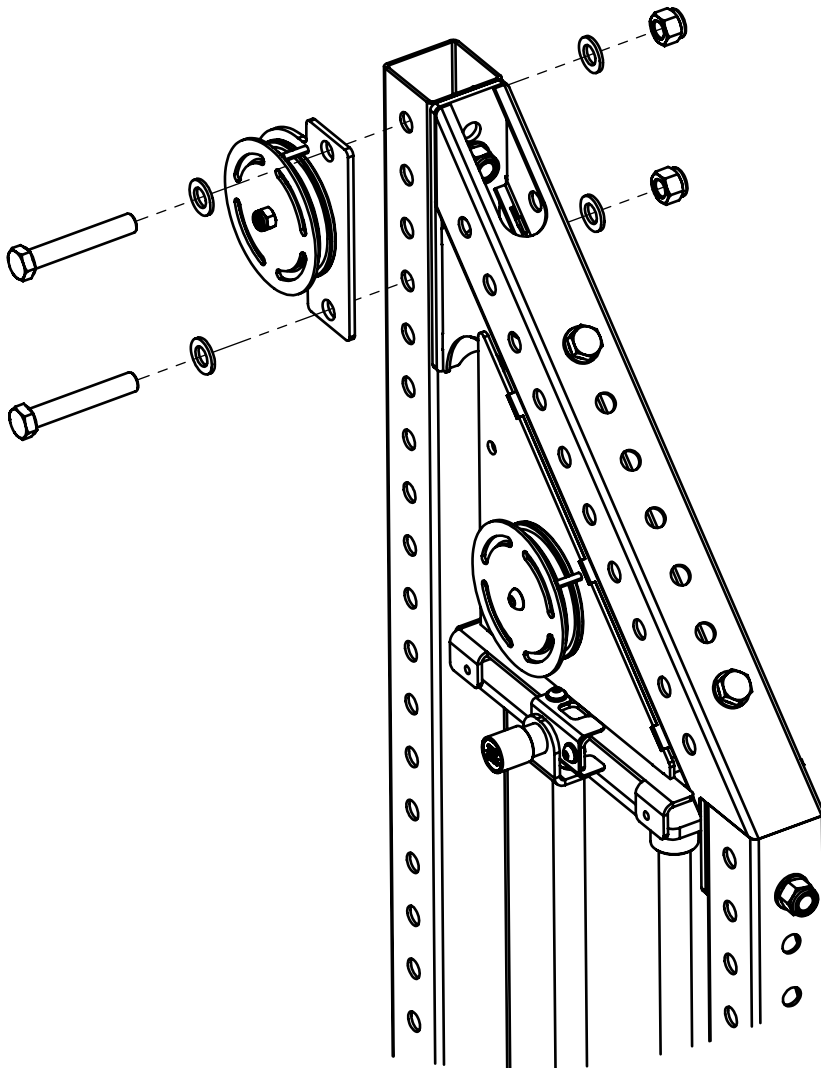

27.

1x

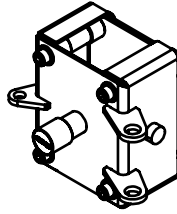

3085601 a3

Remove plate and reassemble on upright!  
Be careful not to let any parts fall out!

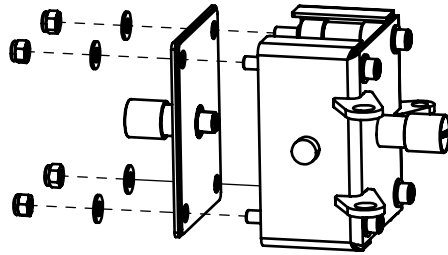

Make sure the screws are not too tight!  
Carriage should be easy to adjust in height!

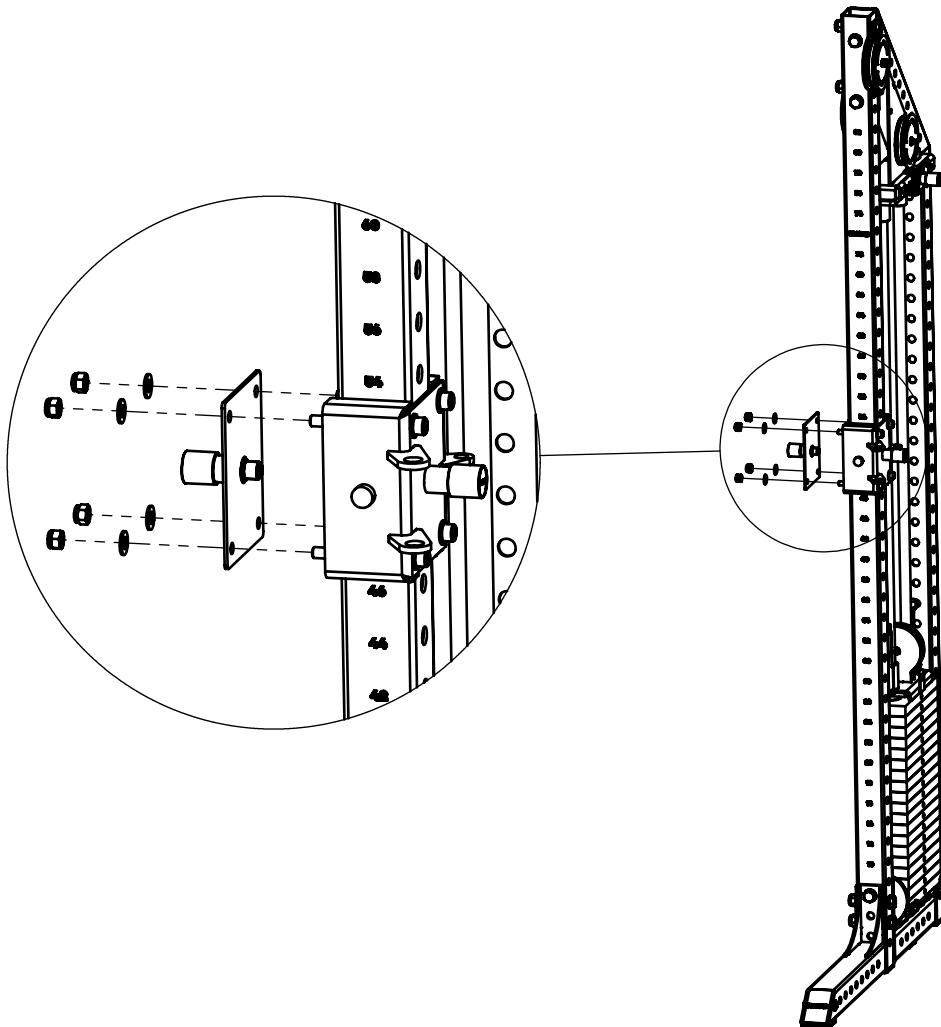

28.

1x



3085601 a6

2x



2001000

1x

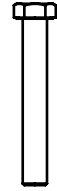

M16 x 110

2x



Washer M16

1x



Locking Nut M16

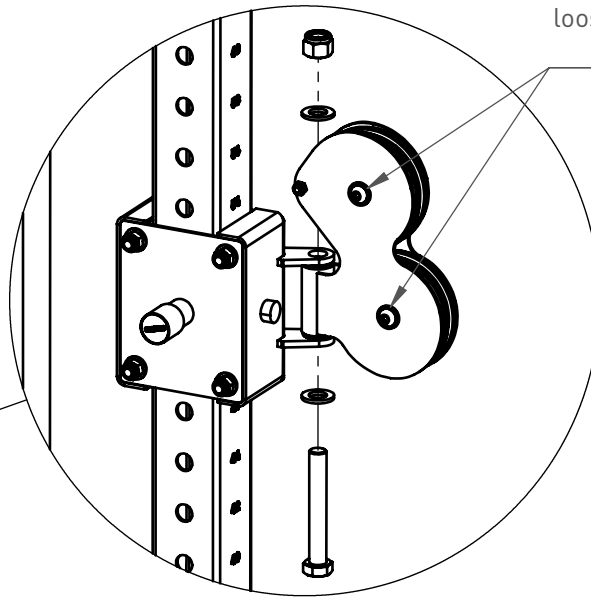
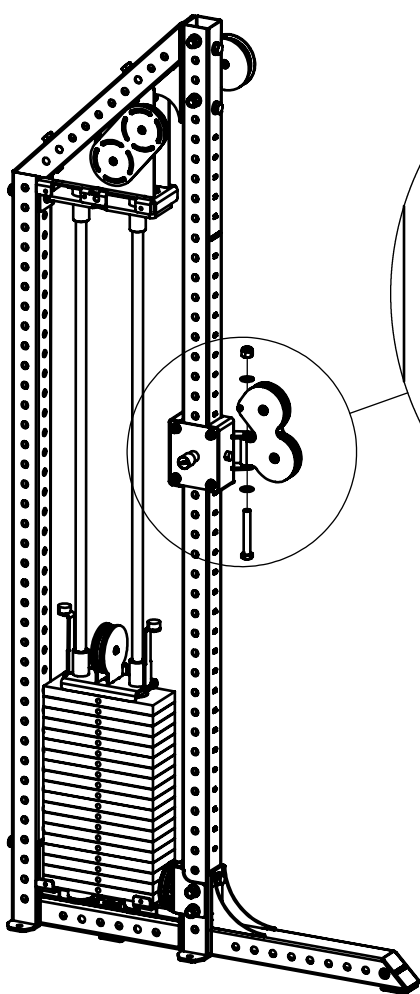
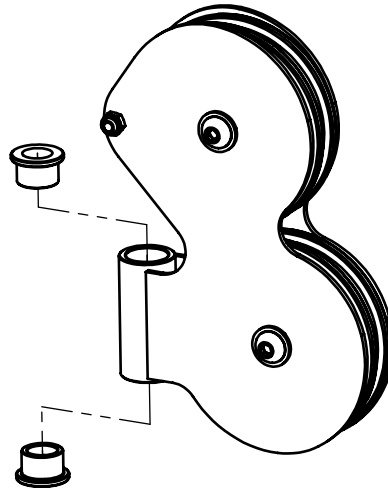

If locking nuts are on this side,  
loosen the screws and turn them so that  
screw heads are on this side!

29.

1x



Hollow Screw

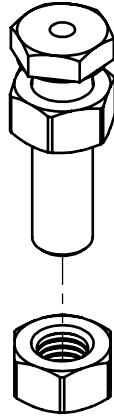

Unscrew nut and mount on carriage!

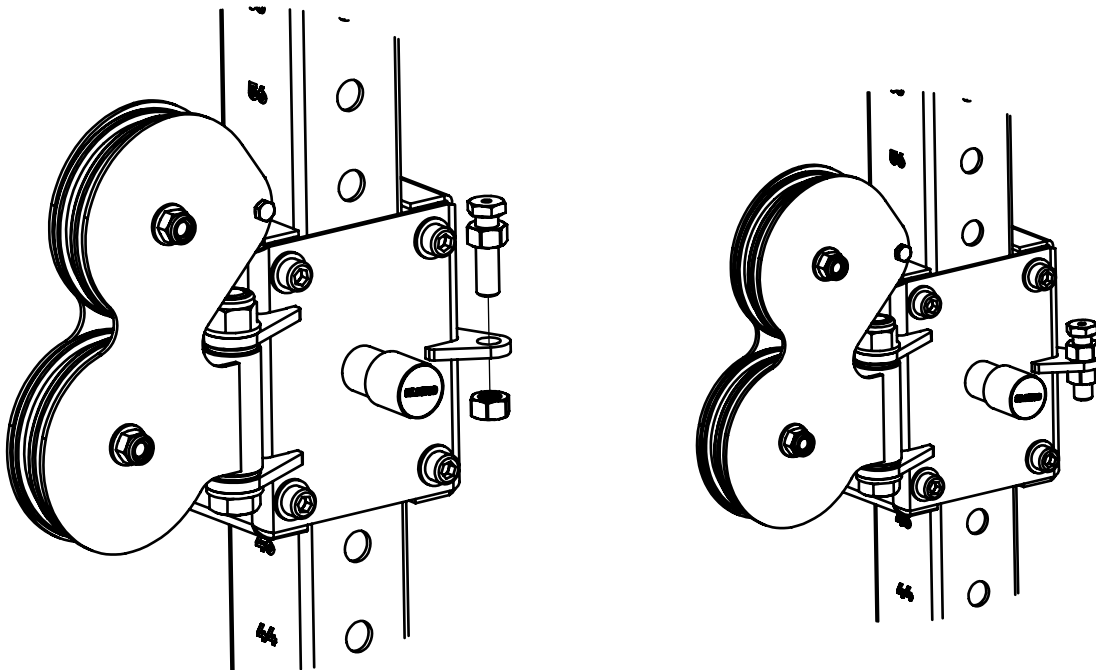

Screw should be as far down as possible!  
Tension in the cable can later be adjusted by moving the screw upwards!

# 30a.

1x

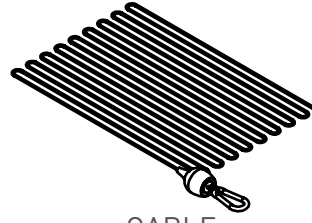

CABLE

Step 1

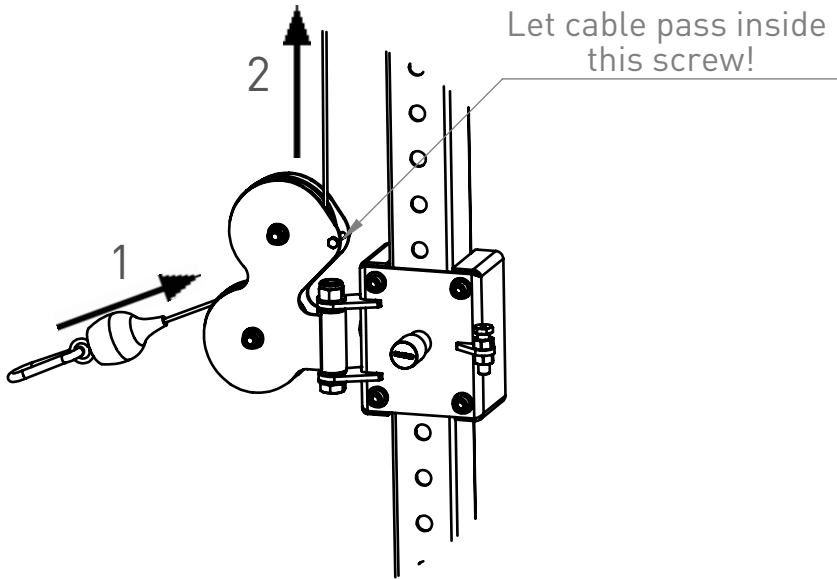

Step 2

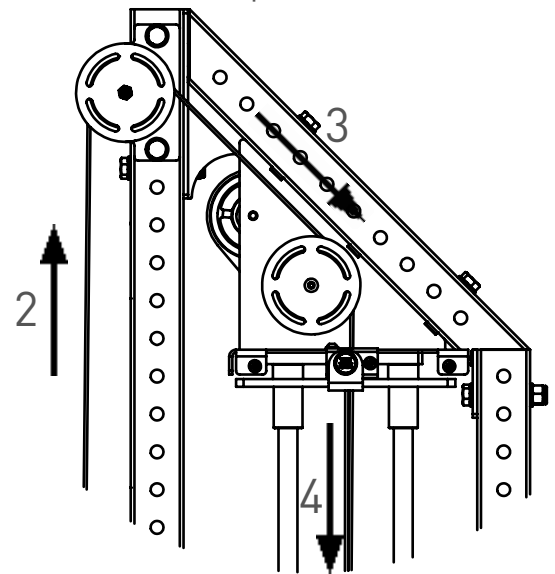

Step 3

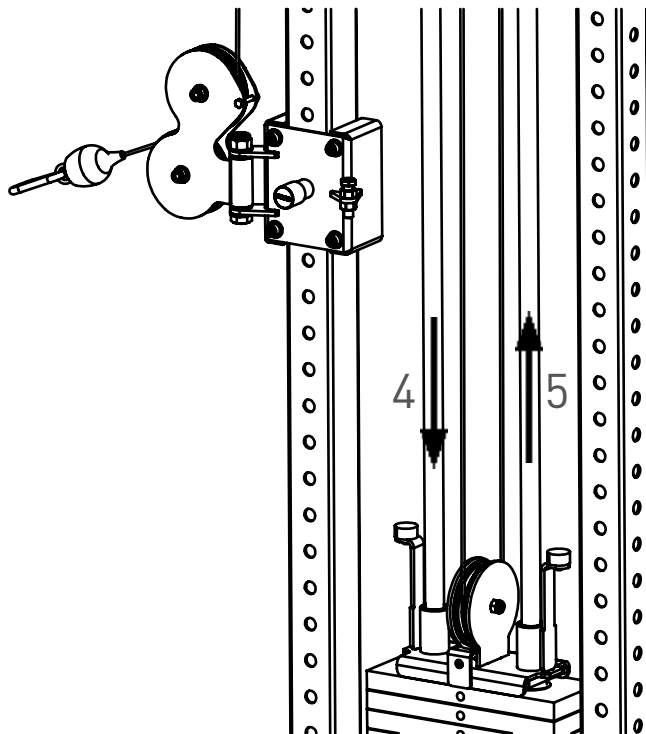



# 30b.

1x



2001808

Step 4

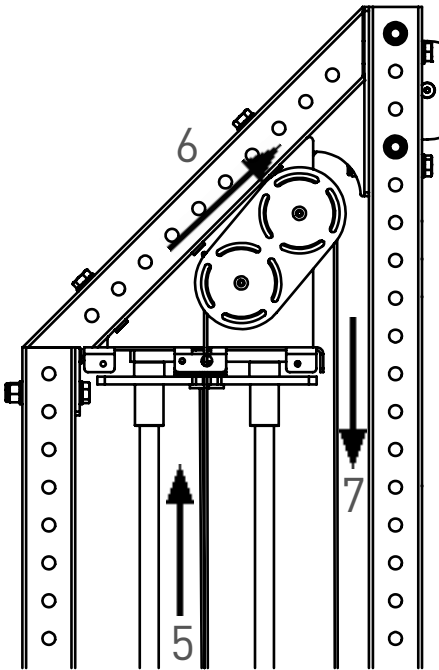

Step 5

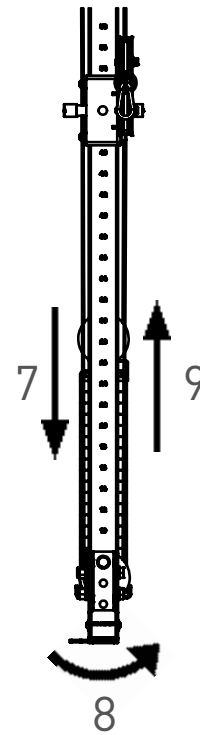

Make sure the cable is tight by pulling its end.  
Let the cable pass through the hollow screw  
before fixing it with the cable end!  
Cut off leftovers from cable!

Step 6

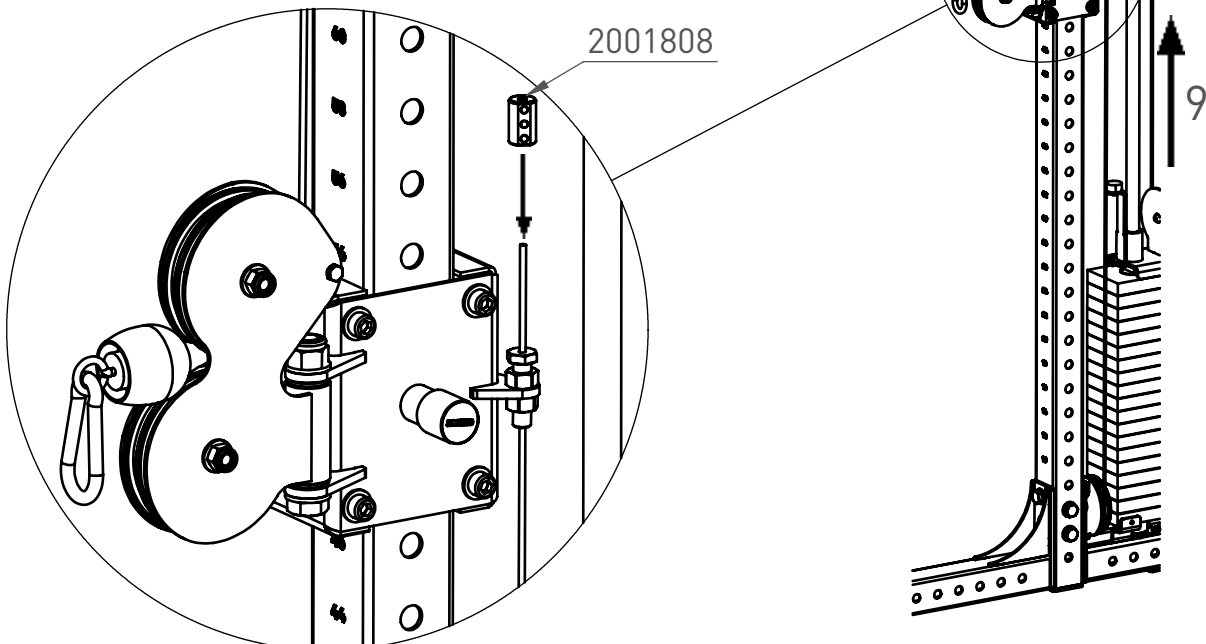

31.

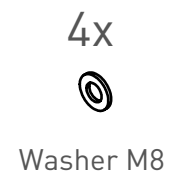
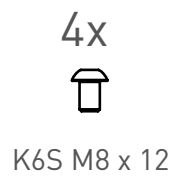
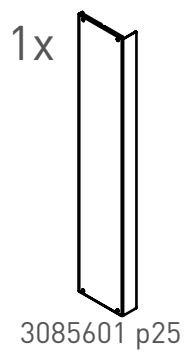

Wipe off both rods again with a clean cloth  
before mounting the cover plate!

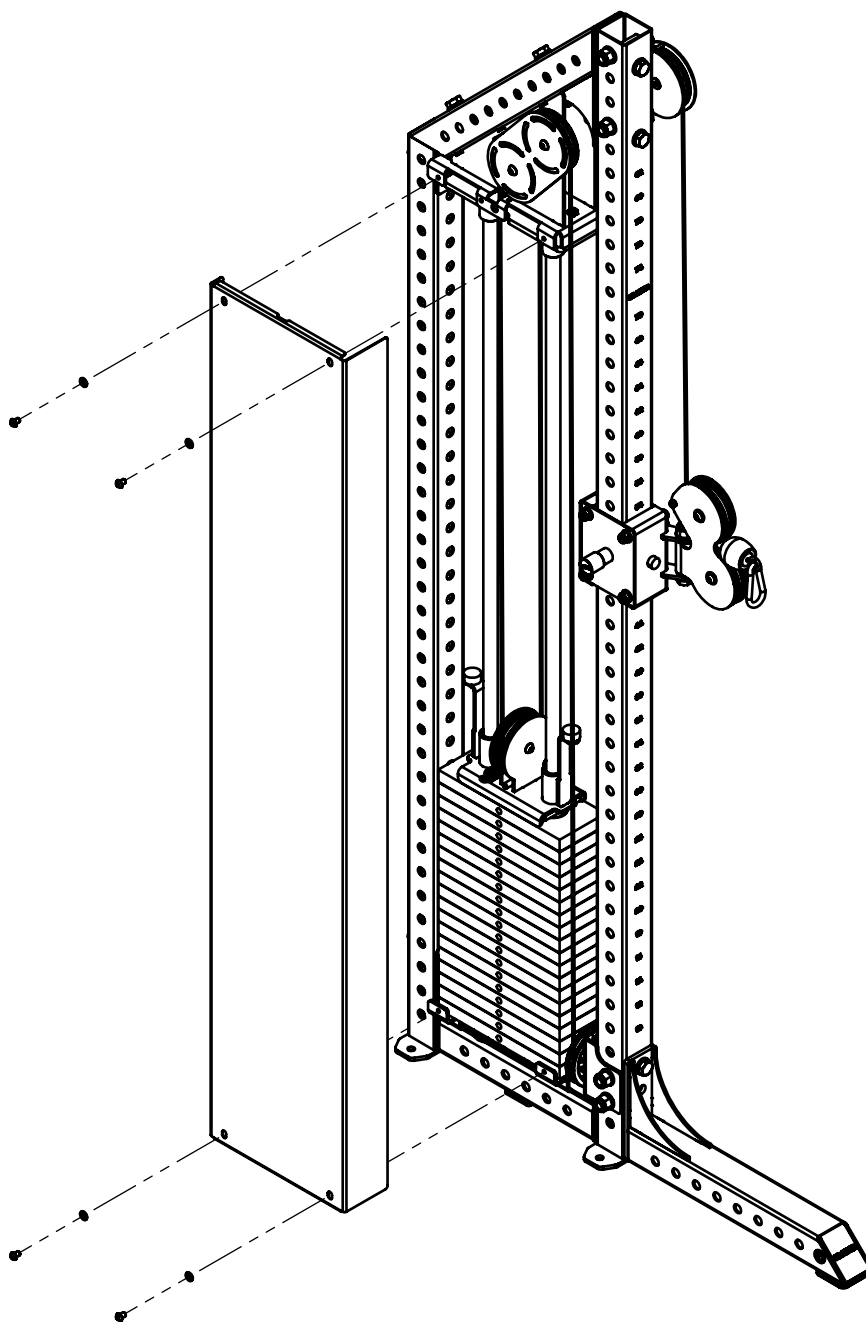

32.

1x

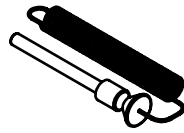

2001483

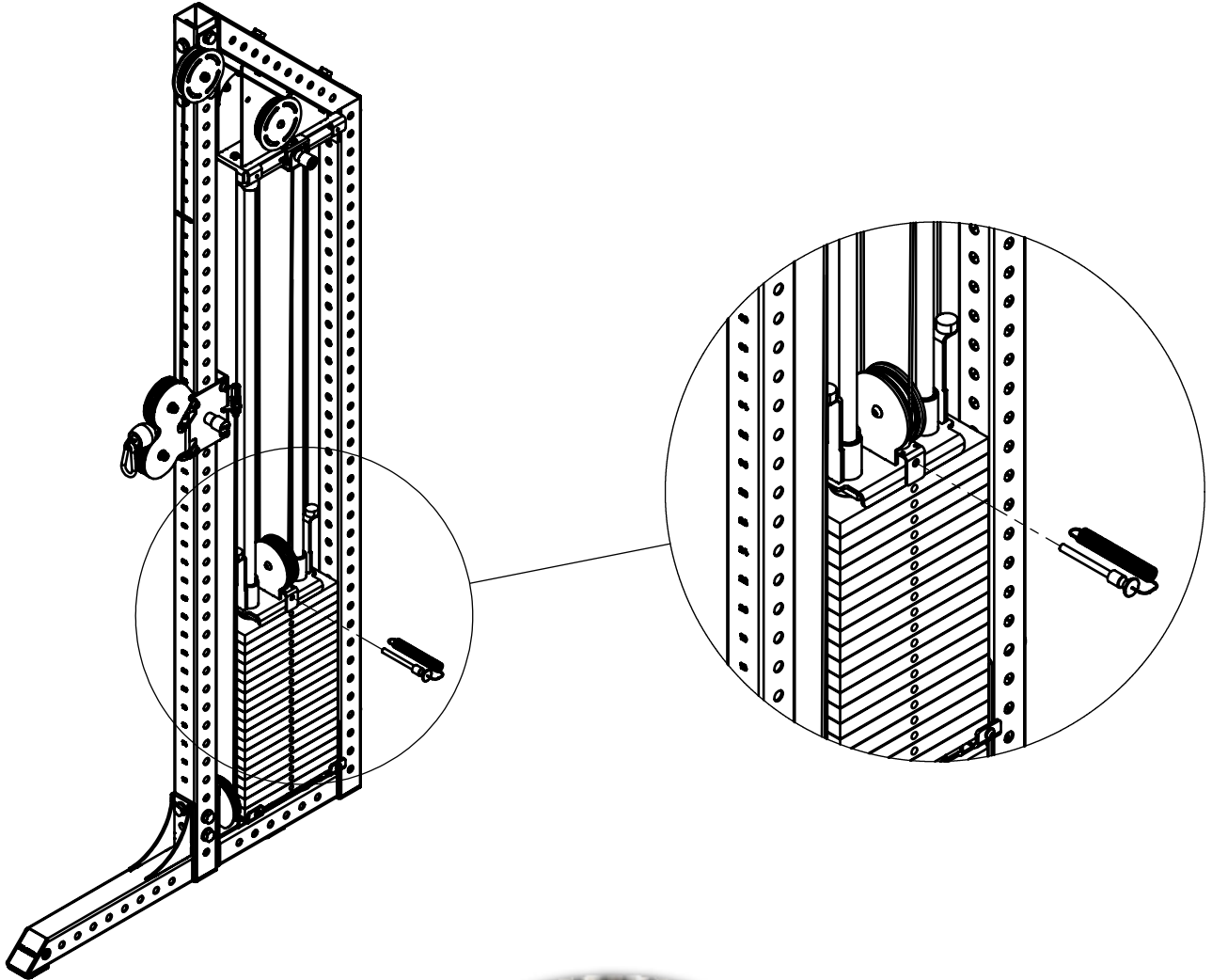

Secure selector pin by threading the metal ring into the left hole!

33.

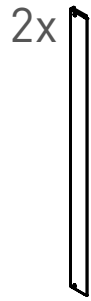

3085601 p11



K6S M8 x 12



Washer M8

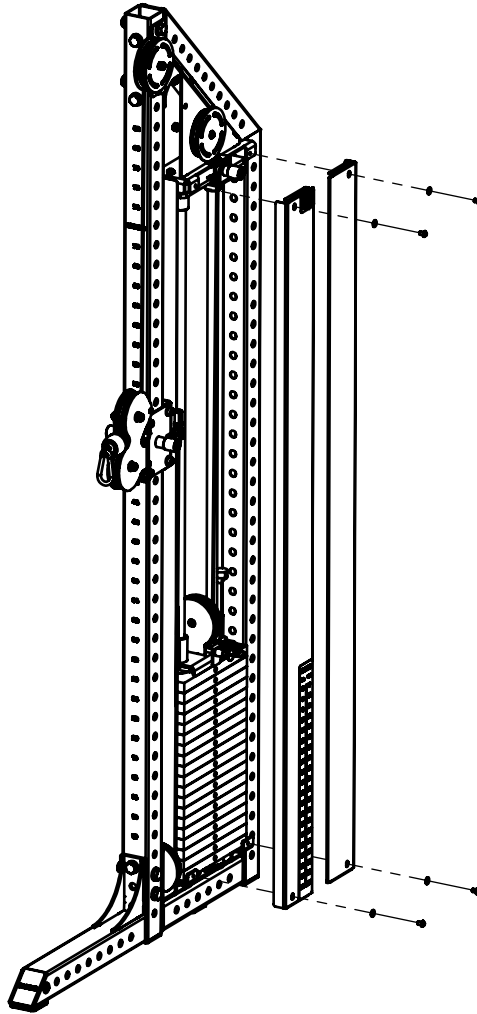

Numbers to the left of the weight stack!

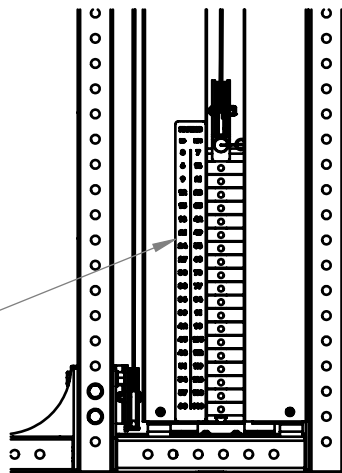

34.

1x

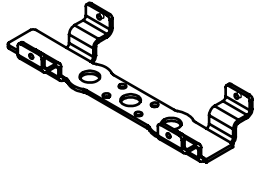

3085601 p8

4x



K6S M8 x 12

4x



Washer M8

Right side

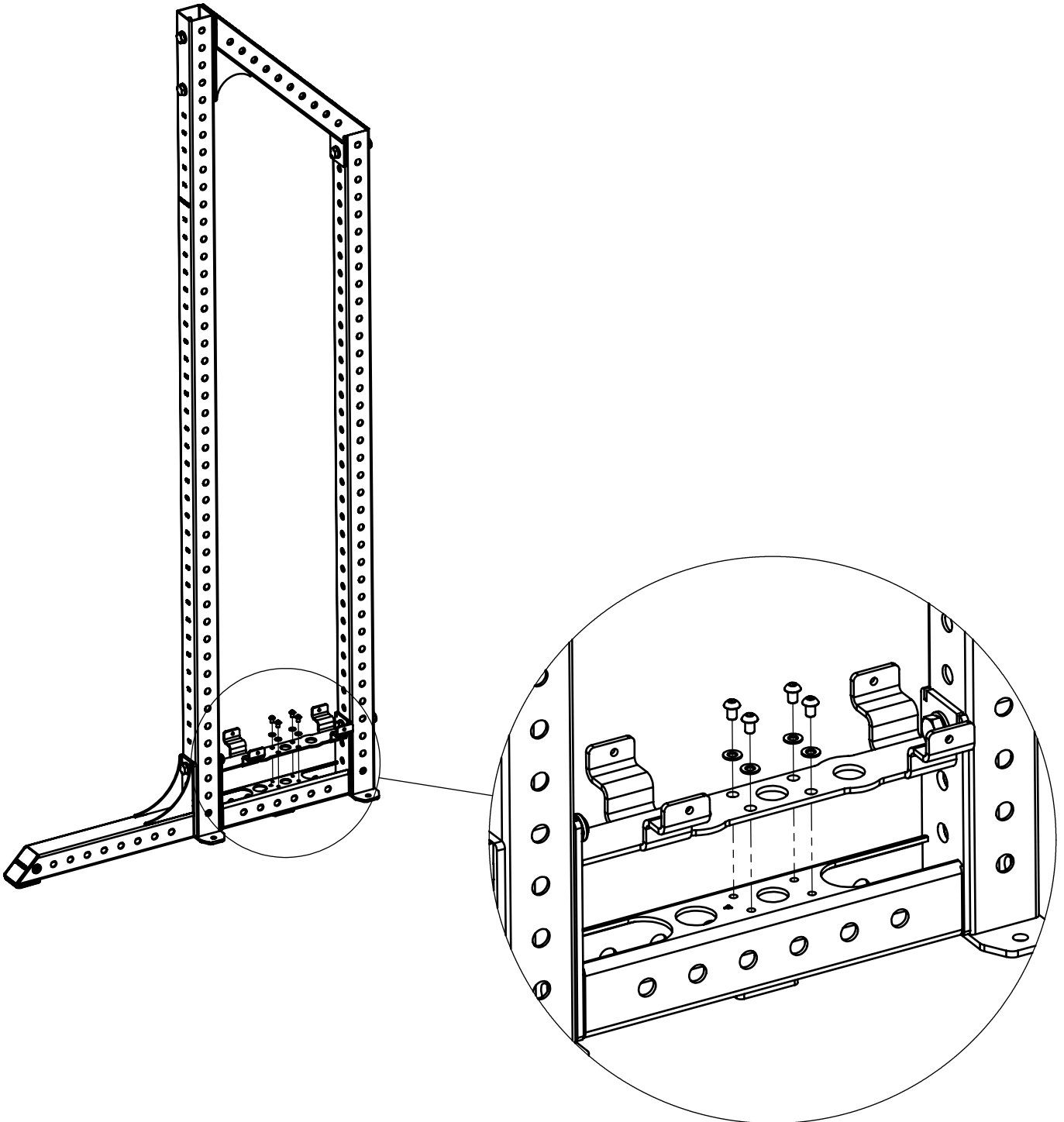

35.

1x

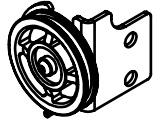

3085601 a8

2x

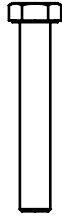

M16 x 100

4x



Washer M16

2x



Locking Nut M16

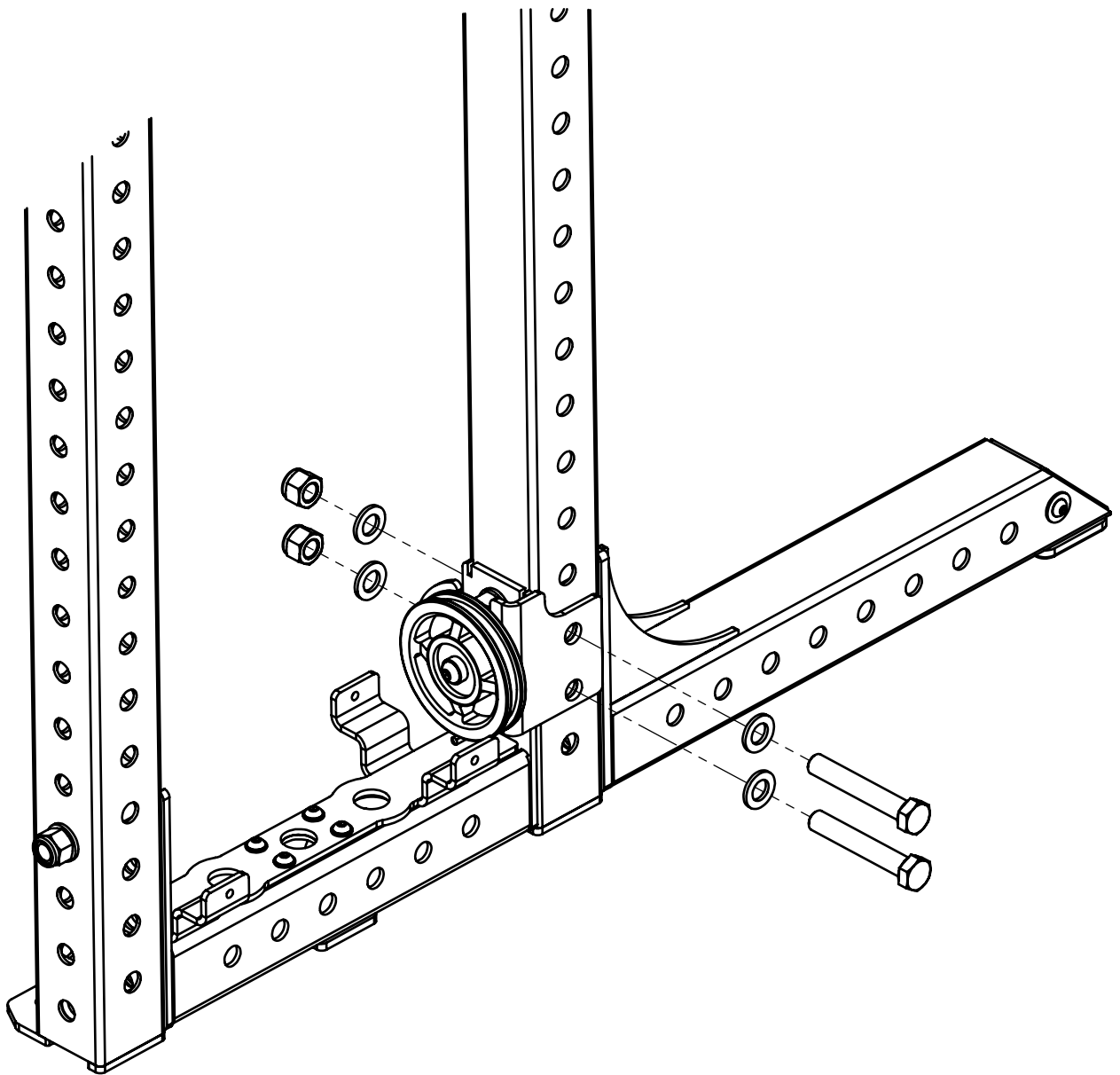

36.

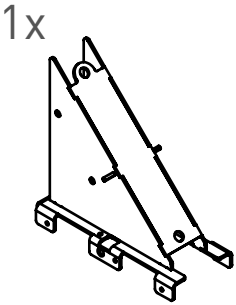

1x

3085601 a7

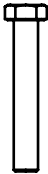

2x

M16 x 100



4x

Washer M16



2x

Locking Nut M16

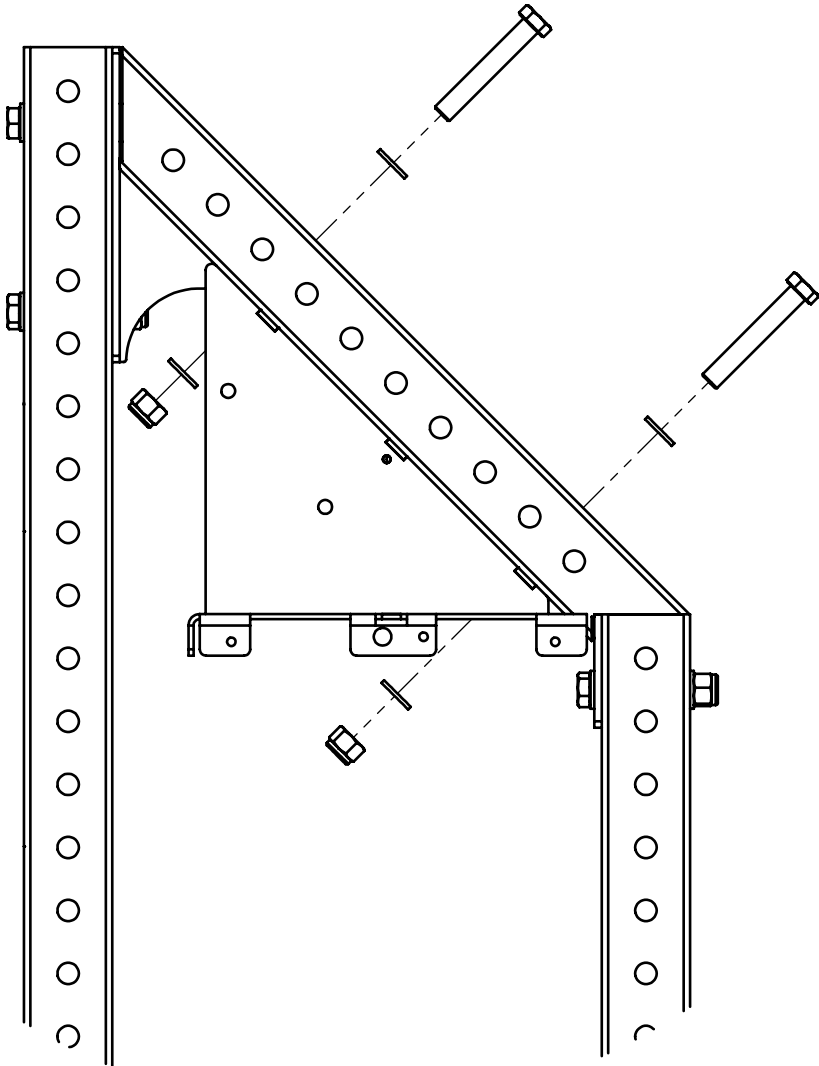

37.

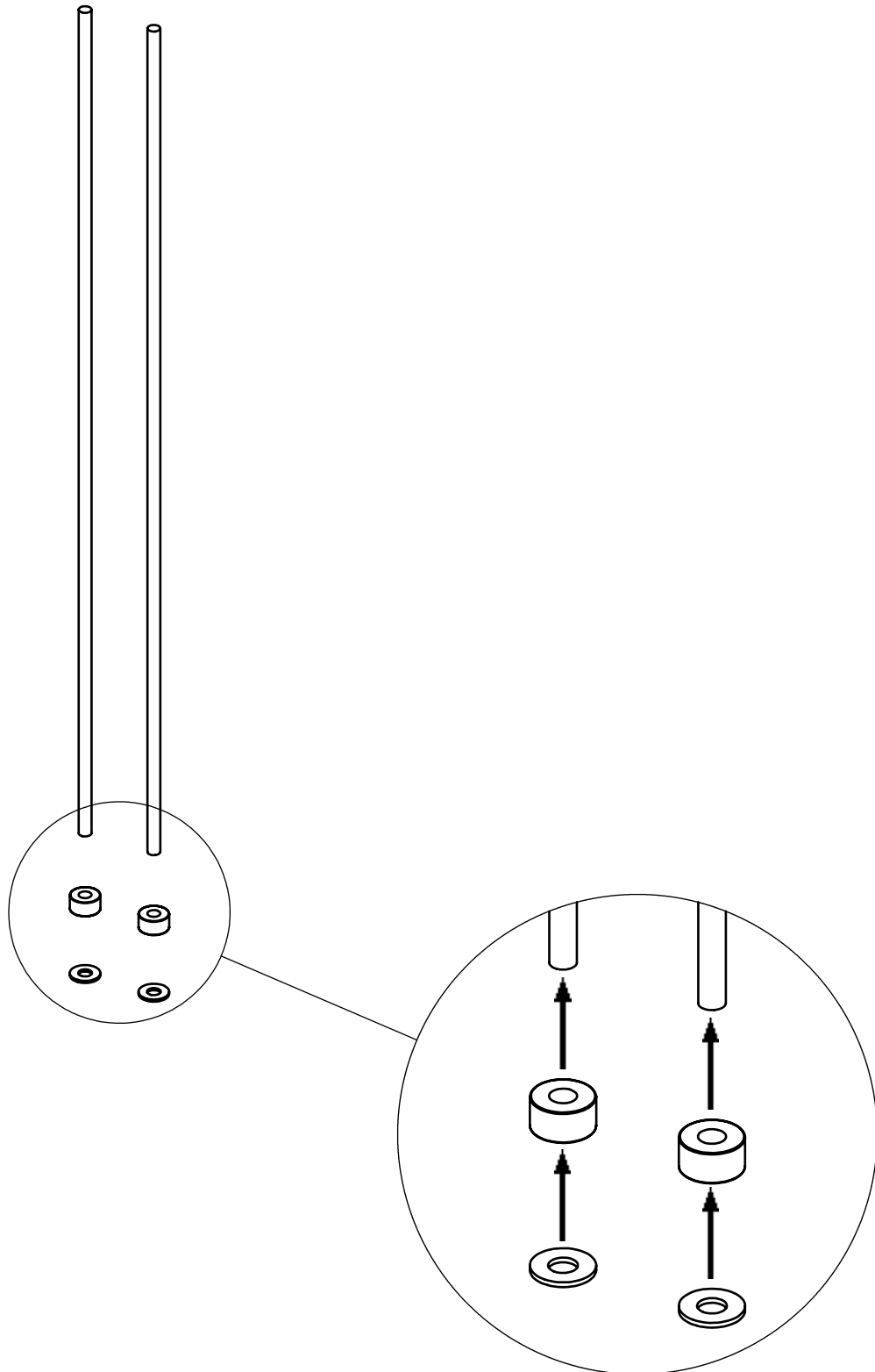
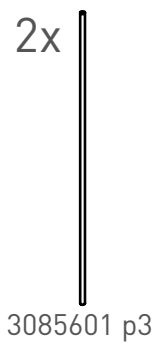



# 38.

Place rods in tilted position in these holes.  
Rubber dampers and distance plates down!

Wipe off both rods with a clean cloth!

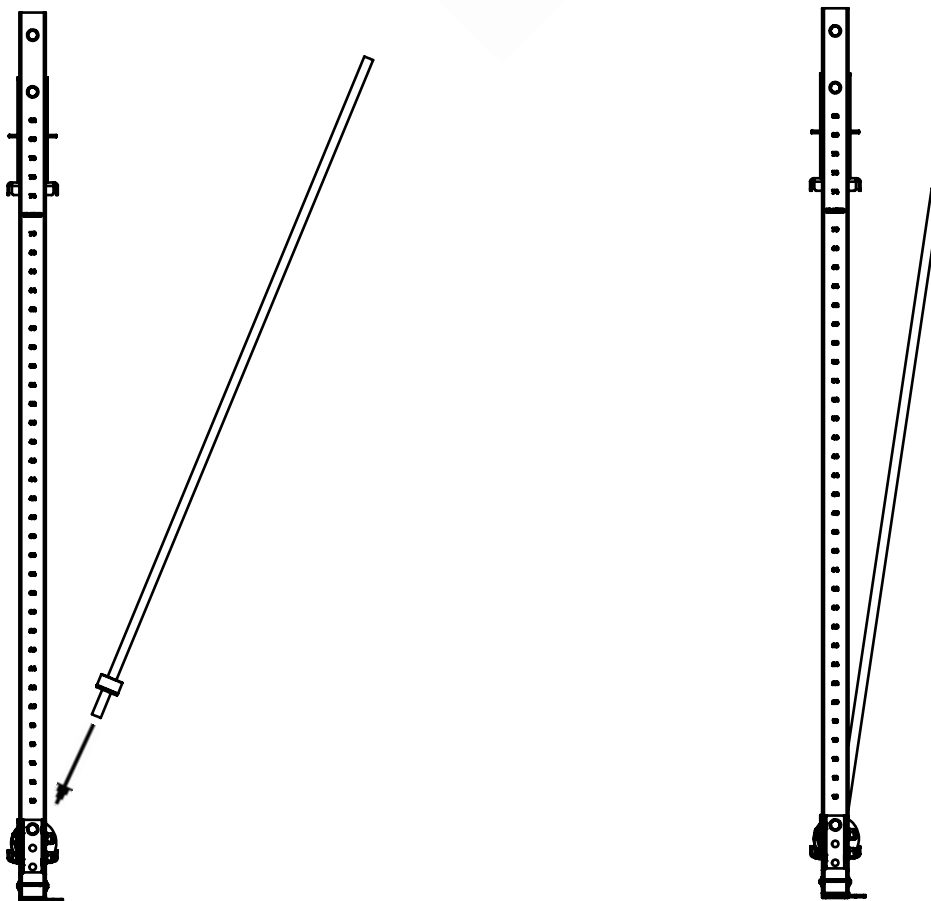
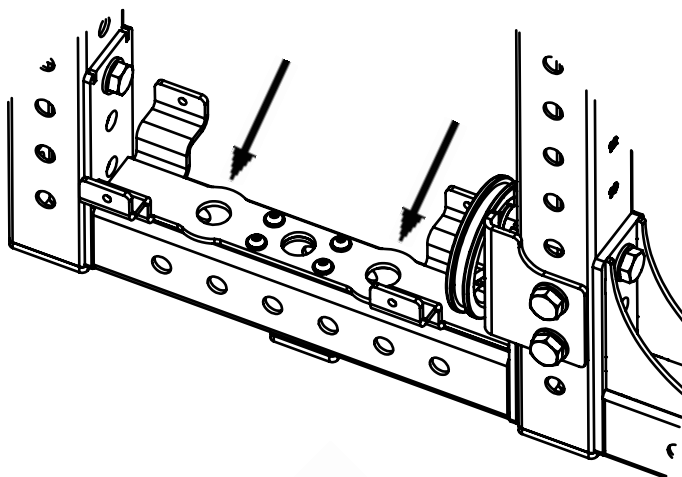

39.

19X (120 kg) / 14X (90 kg)

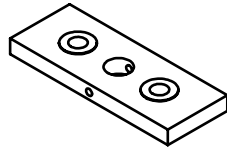

2001590

Assemble the weight stack plate by plate!

Make sure the first plate is pushed all the way down and locked in position!

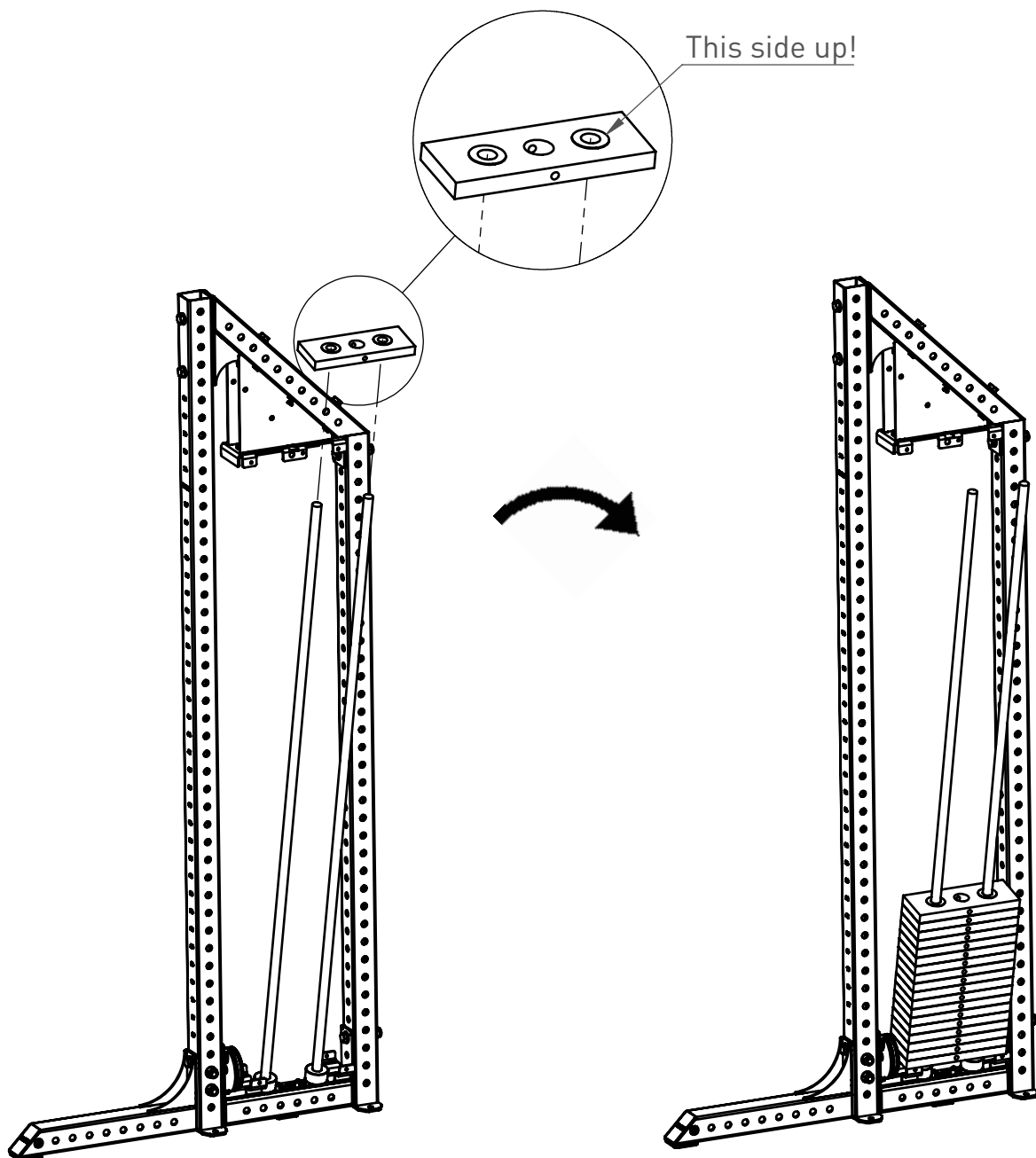

1x

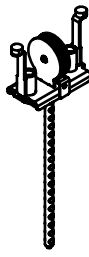

40.

3085601 a1 / 3085880 a1

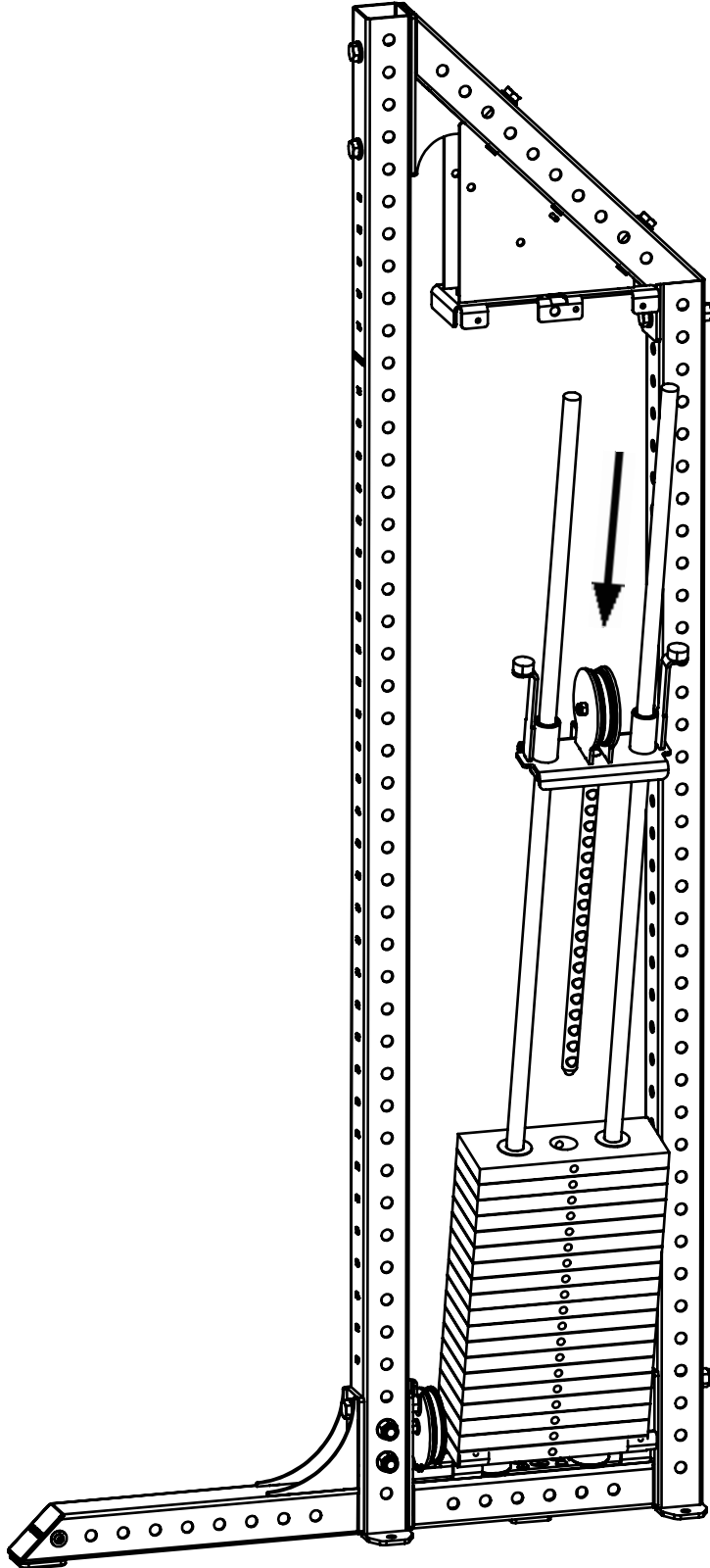

41.

1x

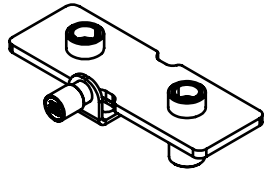

3085601 a2

1x

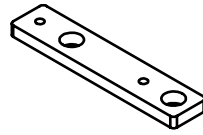

3085601 p9

Mount top weight and plastic top suspension!  
Push to vertical position!

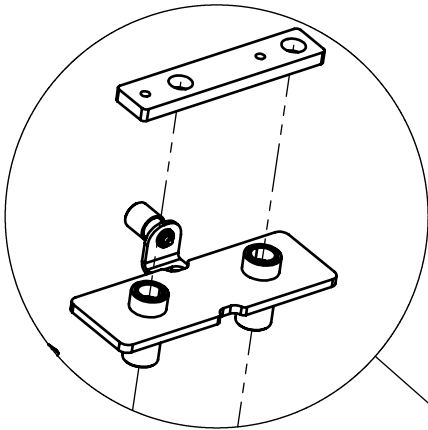

Top weight and plastic top suspension  
must be turned this way!

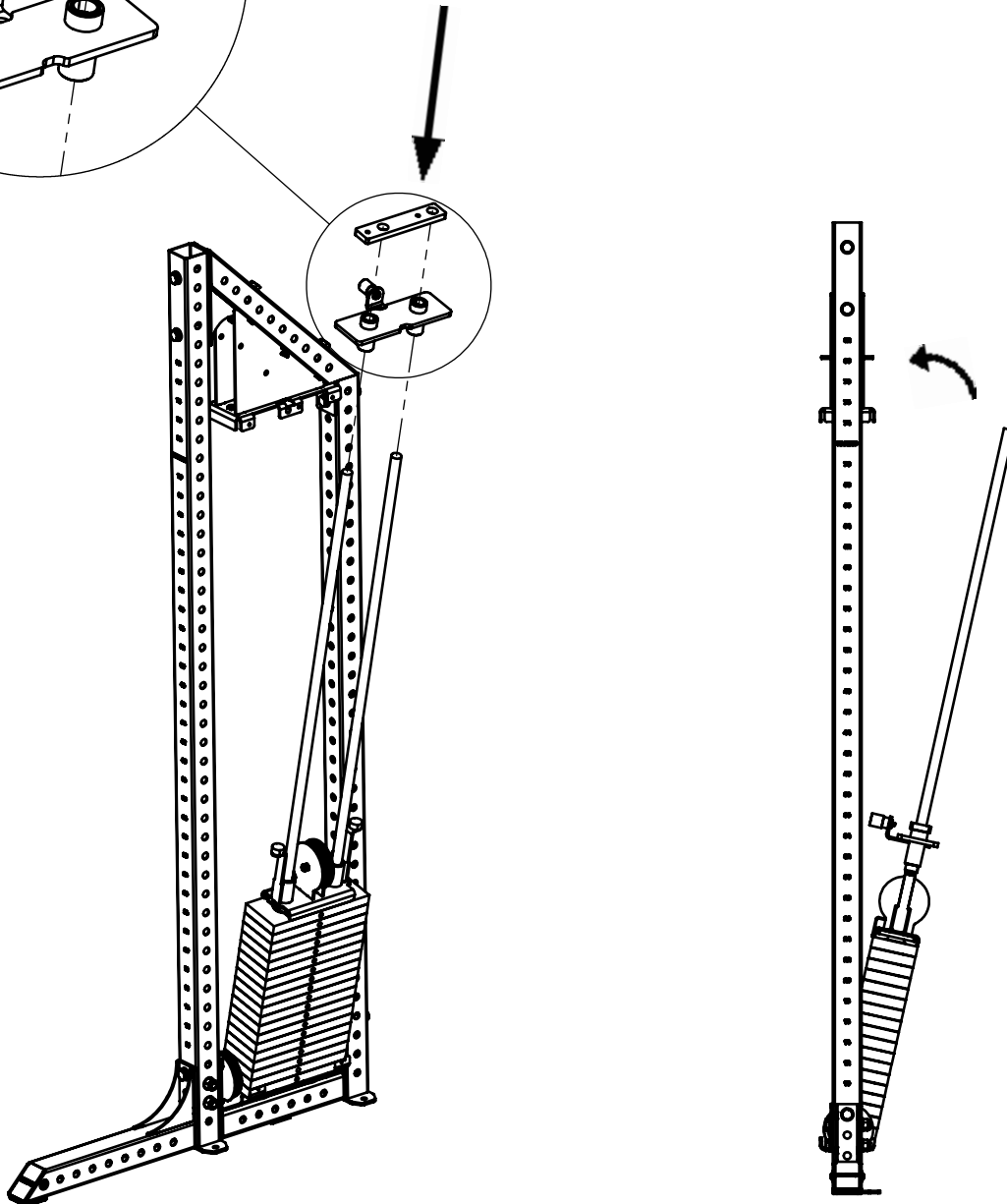

42.

1x

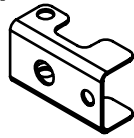

3085601 p6

2x



K6S M8 x 30

2x



K6S M8 x 12

4x



Washer M8

Plastic top suspension  
from previous step!

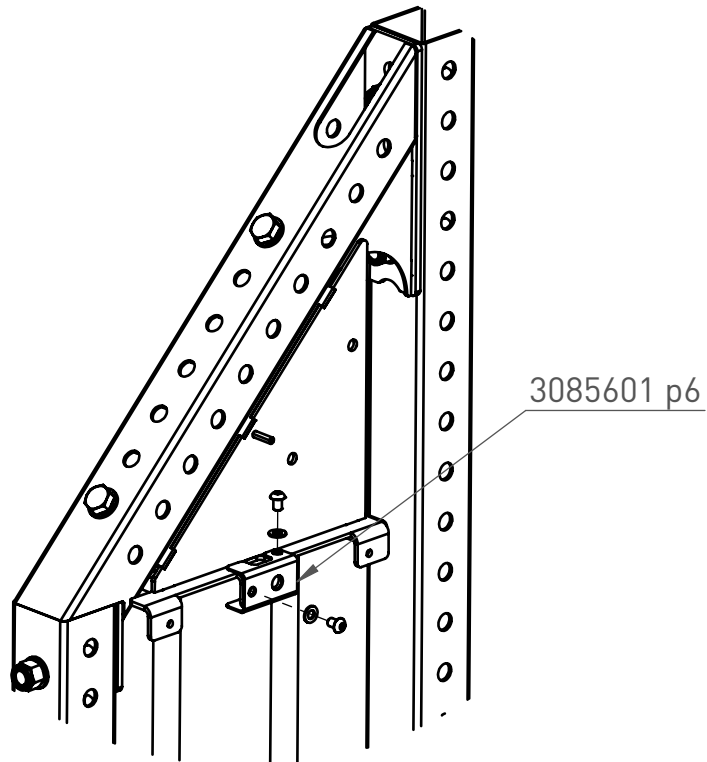
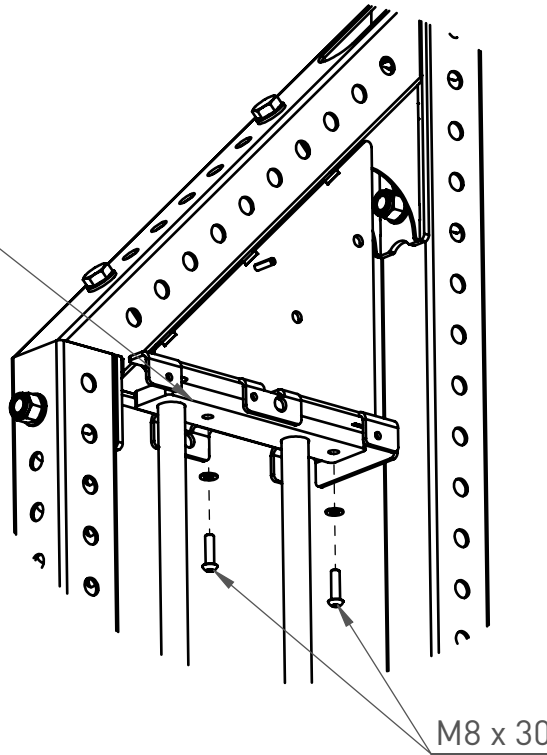

The weight increment can now be secured  
in a top position with help of the pop-pin!

43.

1x



Double Wheel Kit

1x



Single Wheel Kit

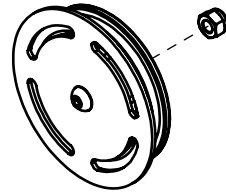
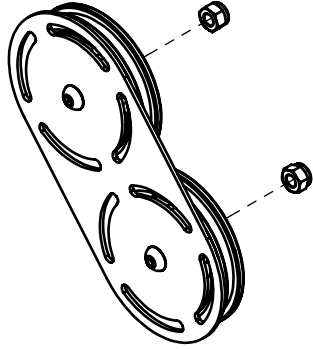

Unscrew nuts and mount both wheel kits!

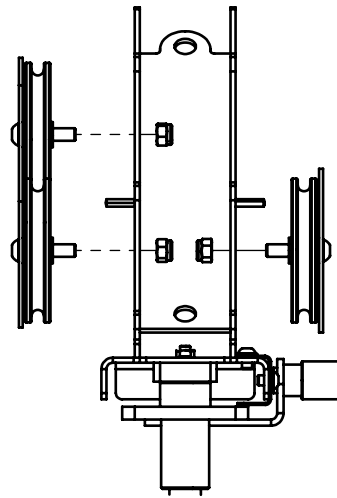
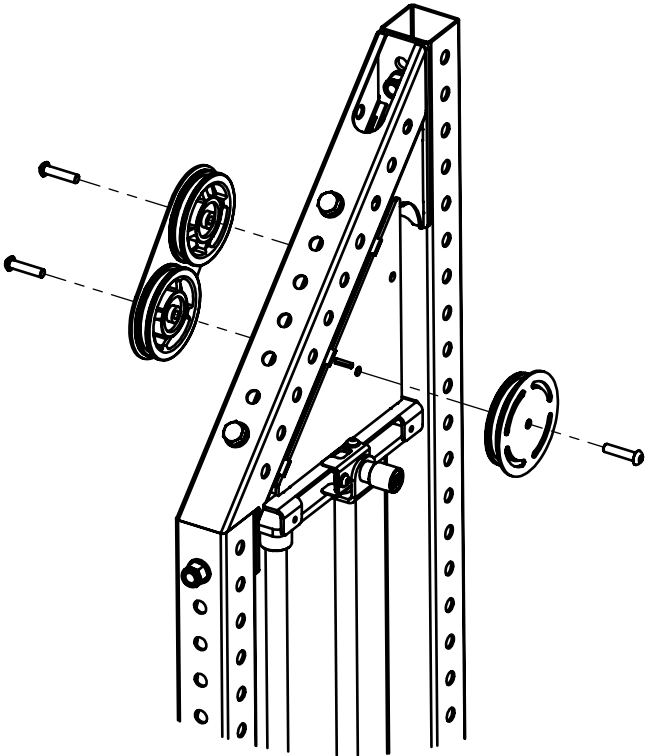

44.

1x



3085601 a9

2x



M16x100

4x



Washer M16

2x



Locking Nut M16

These screws can be found in the screw kit that came with the frame!

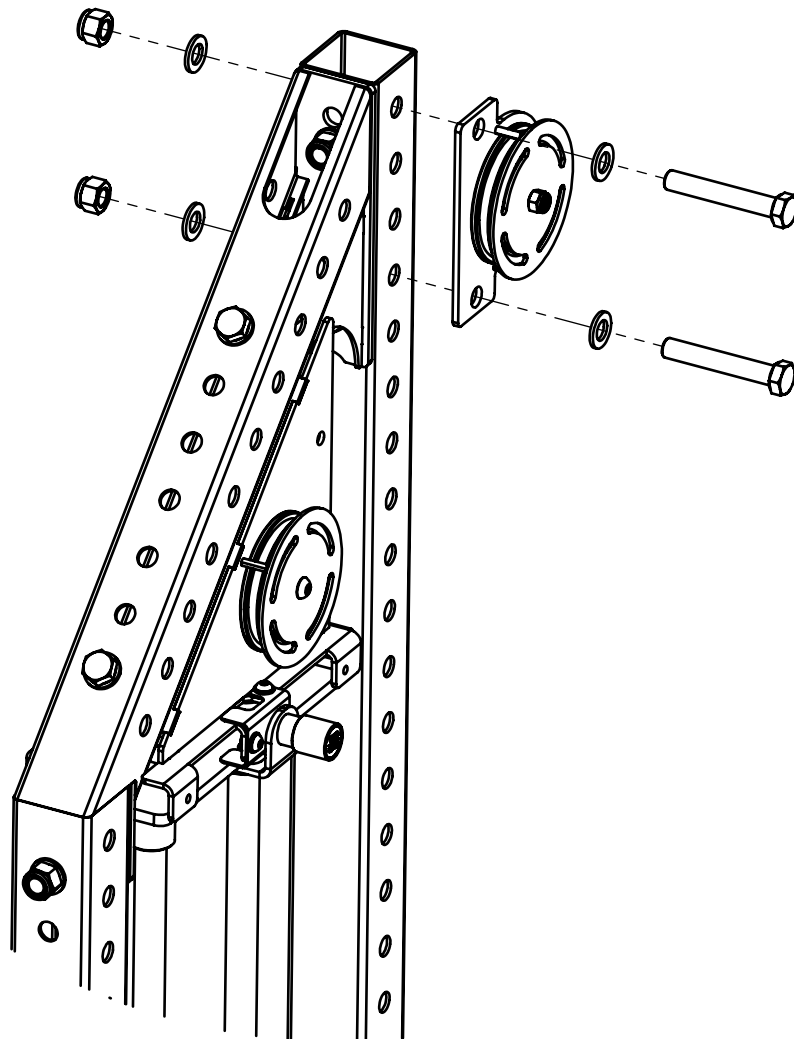

45.

1x

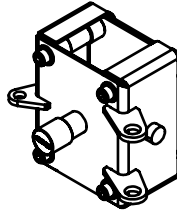

3085601 a3

Remove plate and reassemble on upright!  
Be careful not to let any parts fall out!

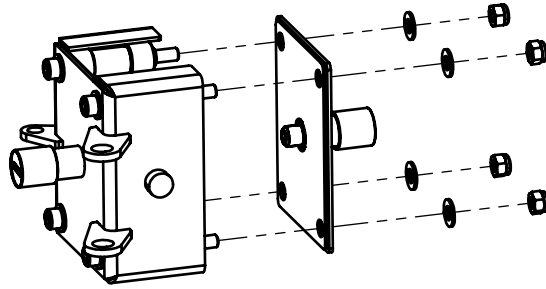

Make sure the screws are not too tight!  
Carriage should be easy to adjust in height!

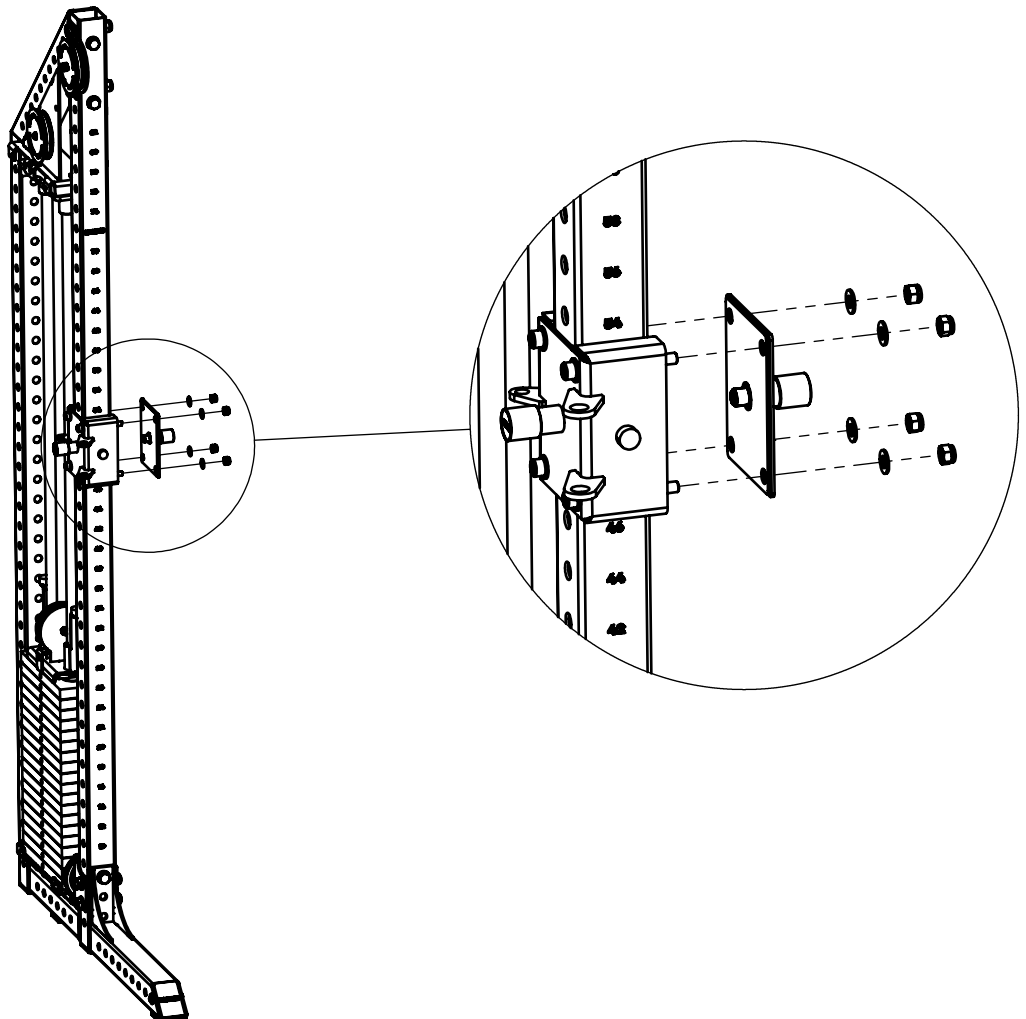



46.

1x



3085601 a6

2x



2001000

1x



M16 x 110

2x



Washer M16

1x



Locking Nut M16

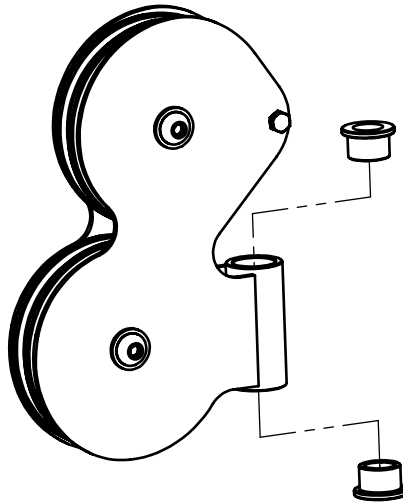

If locking nuts are on this side,  
loosen the screws and turn them so that  
screw heads are on this side!

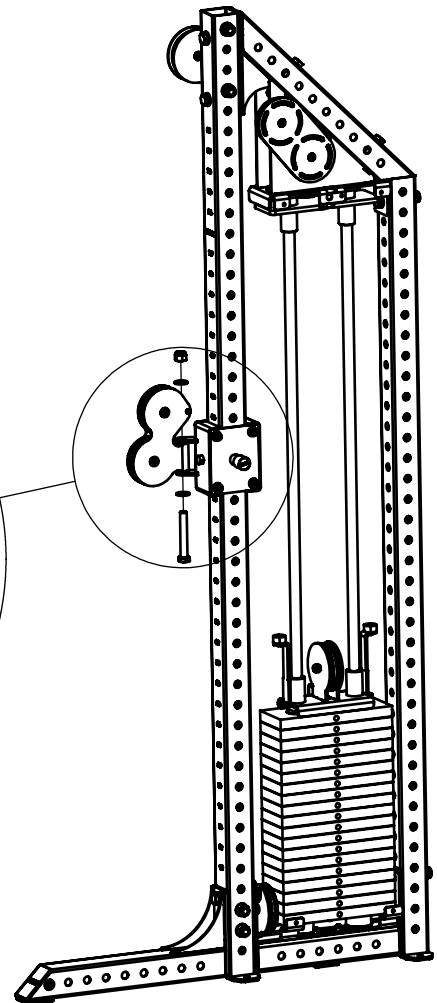
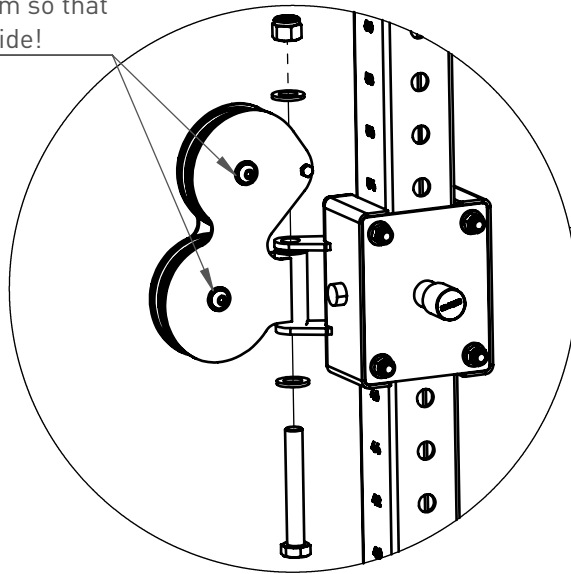

47.

1x



Hollow Screw

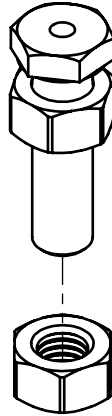

Unscrew nut and mount on carriage!

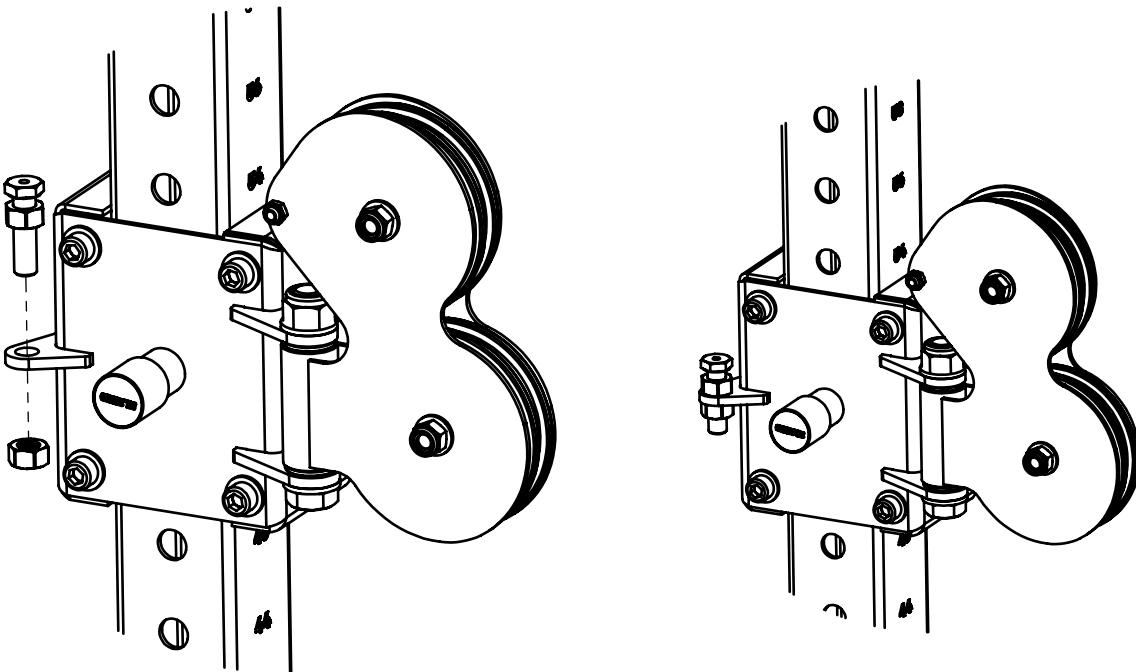

Screw should be as far down as possible!  
Tension in the cable can later be adjusted by moving the screw upwards!

48a.

1x

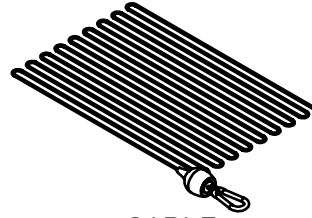

CABLE

Step 1

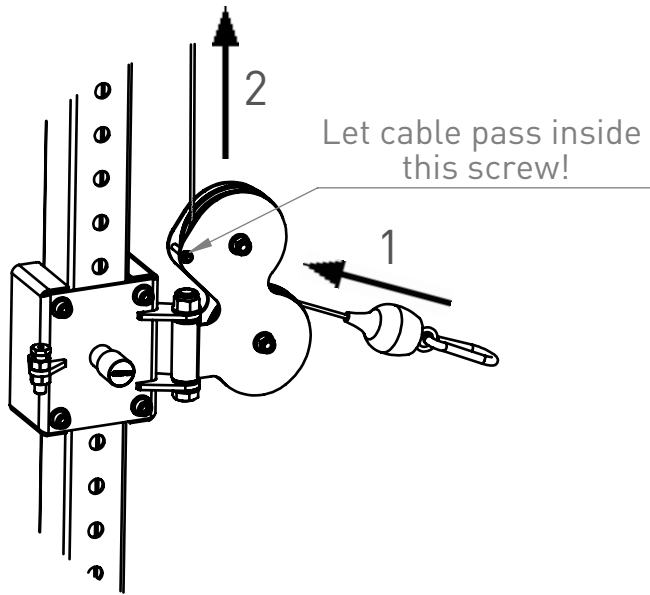

Step 2

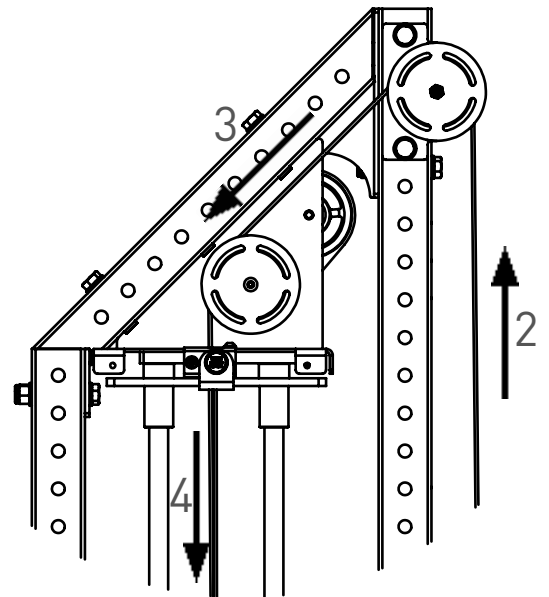

Step 3

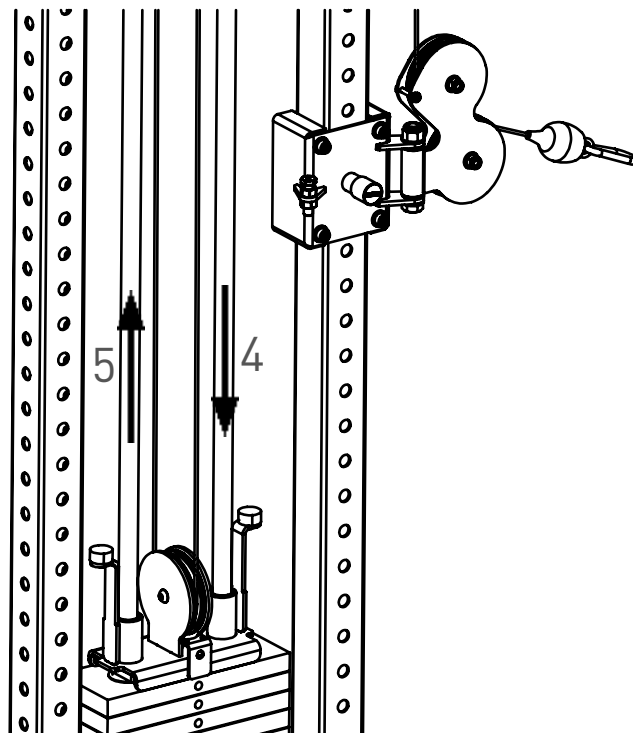

# 48b.

1x



2001808

Step 4

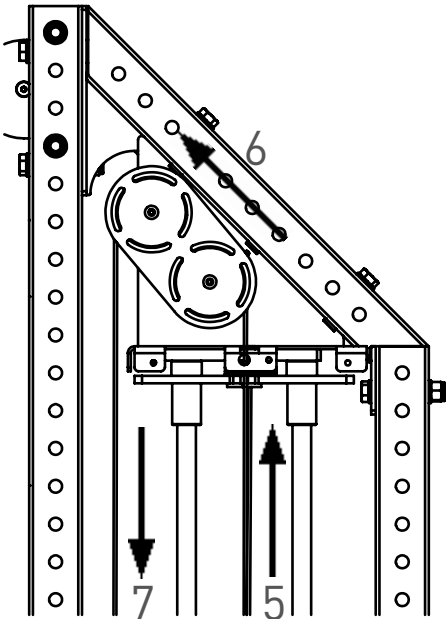

Step 5

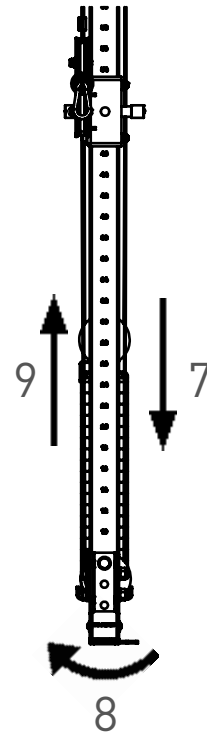

Step 6

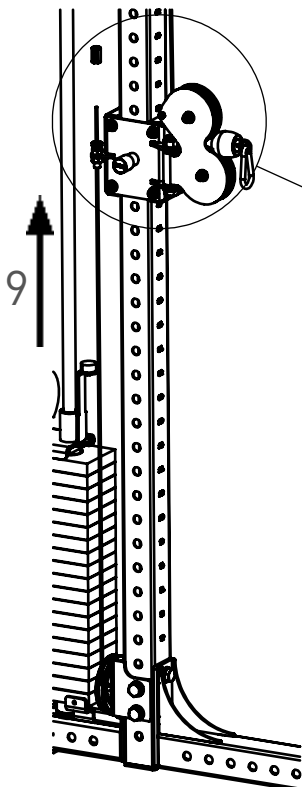

Make sure the cable is tight by pulling its end.  
Let the cable pass through the hollow screw  
before fixing it with the cable end!  
Cut off leftovers from cable!

2001808

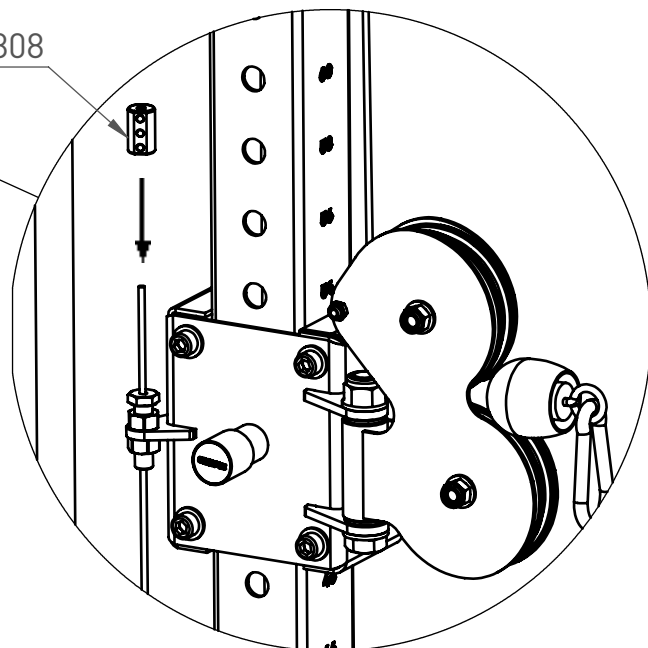

49.

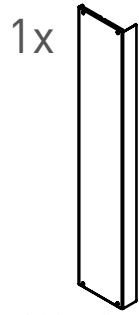

1x  
3085601 p25

4x



K6S M8 x 12

4x



Washer M8

Wipe off both rods again with a clean cloth  
before mounting the cover plate!

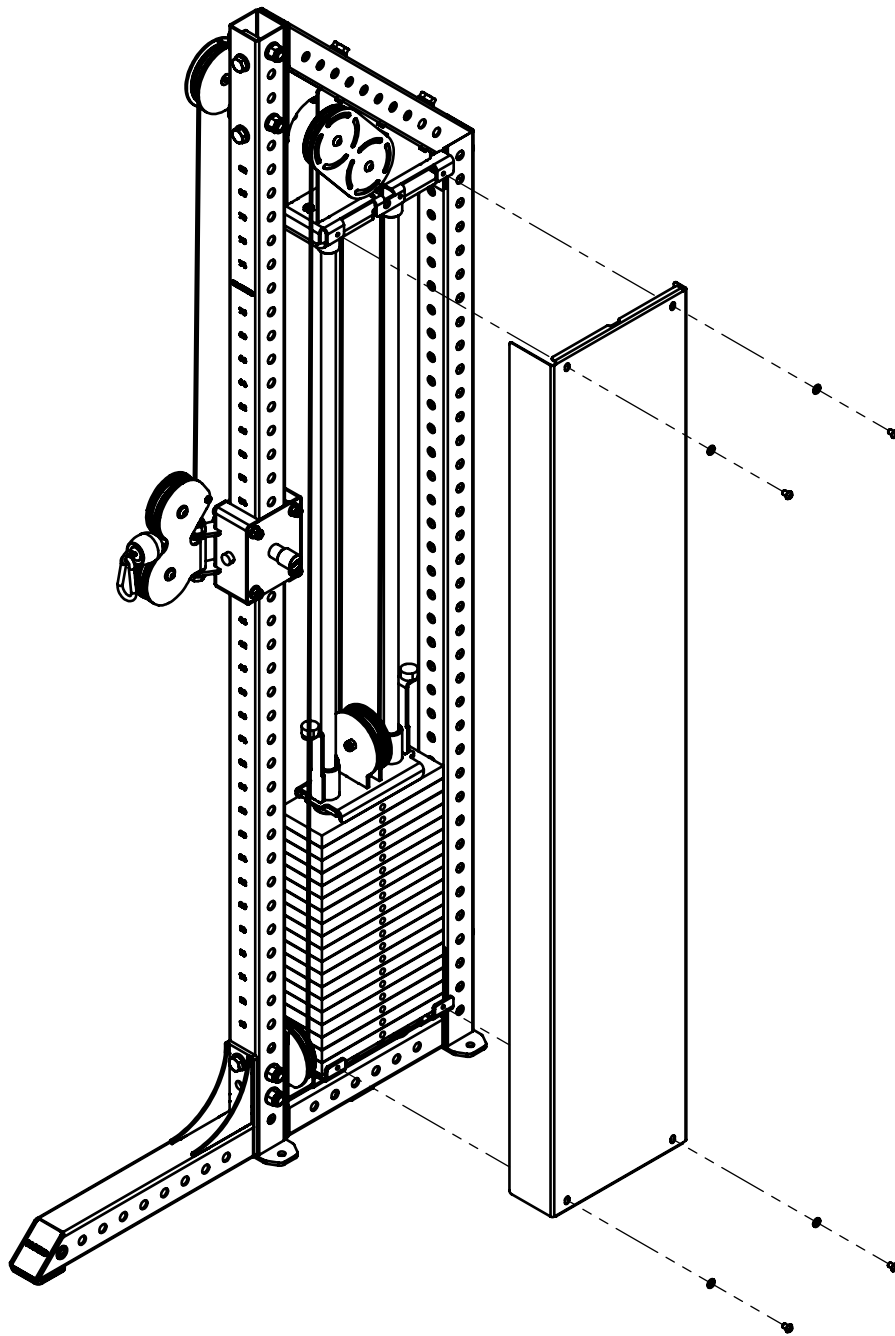

50.

1x

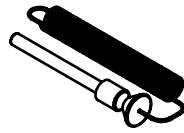

2001483

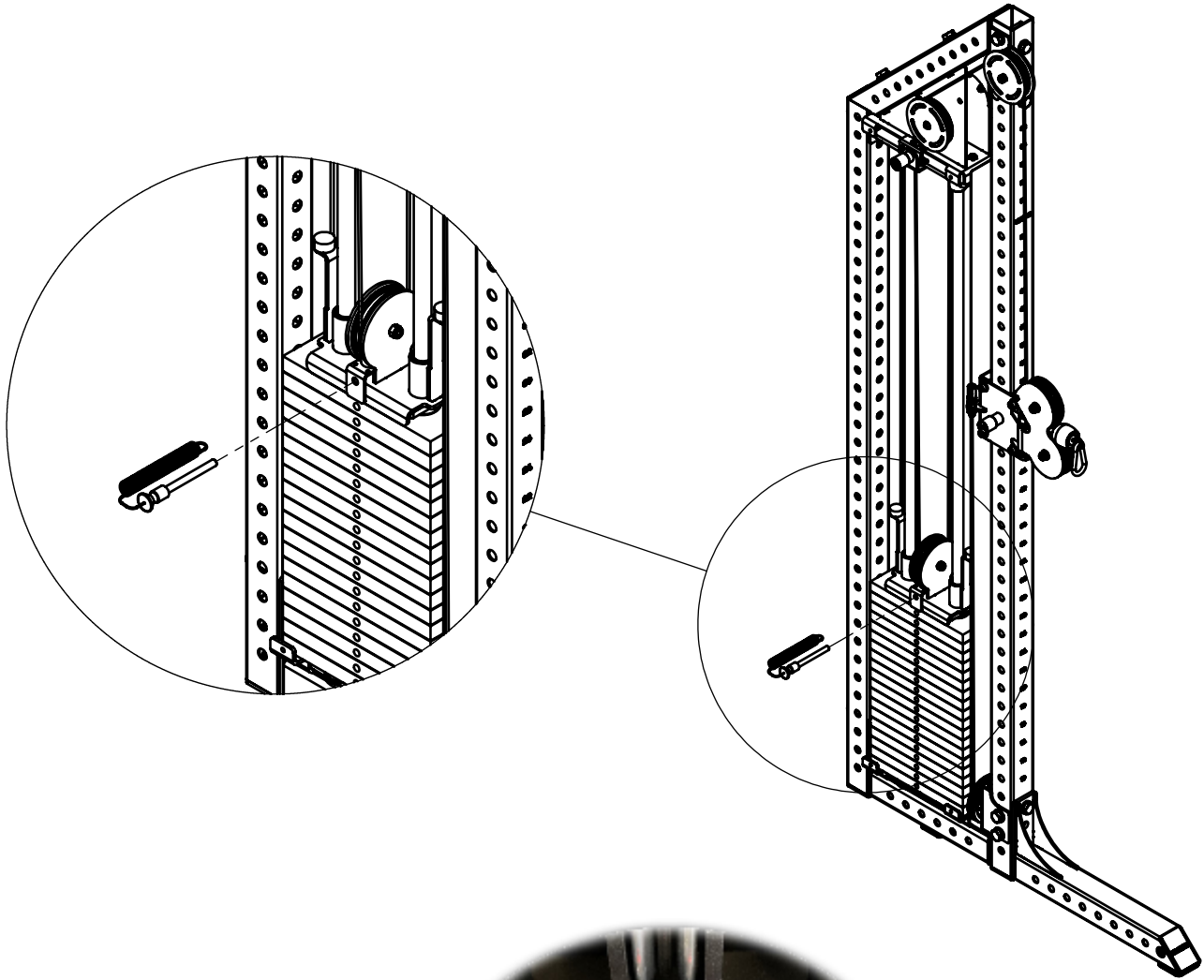

Secure selector pin by threading the metal ring into the left hole!

51.

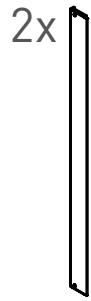

3085601 p11

4x



K6S M8 x 12

4x



Washer M8

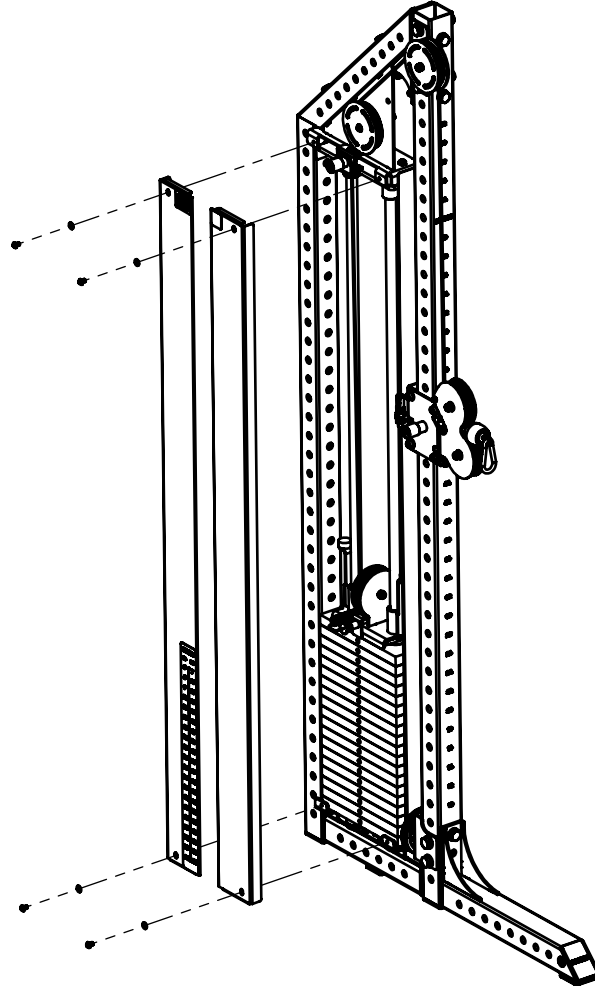

Numbers to the left  
of the weight stack!

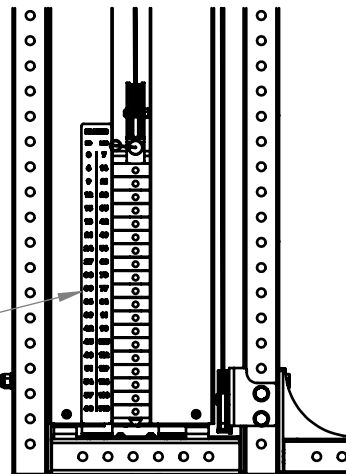

# USER GUIDE

## PURPOSE

The Eleiko Prestera Dual Adjustable Pulley provides users with a wide range of exercises that target all muscle groups. All with a small foot print.

## GENERAL INSTRUCTIONS FOR USE

1. Use the selector pin to select training weight.
2. Adjust height on carriage by pulling the pop-pins.
3. Switch to different handles depending on exercise.
4. Release 1,5 kg / 3,5 lbs weight increment by pulling pop-pin.

## PRODUCT SPECIFICATION

Max weight Pull-Up Bar	150 kg
Max training weight	120 kg / 265 lbs
Product weight	475 kg / 1047 lbs (120 kg weight stack) 415 kg / 915lbs (90 kg weight stack)
Dimensions (L x W x H)	1212 x 1936 x 2368 mm 47,7 x 76,2 x 93,2"

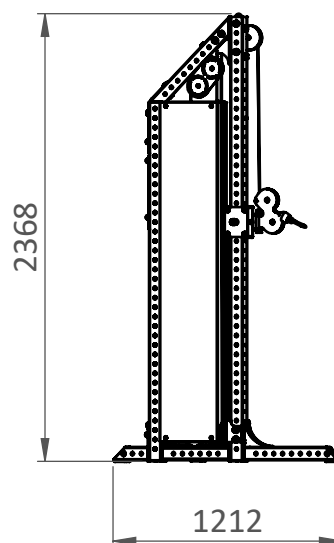
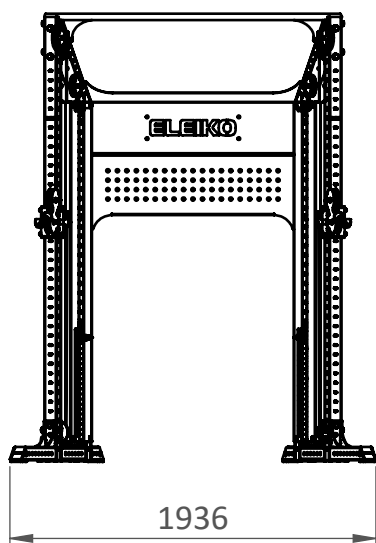



# CARE AND MAINTENANCE

## PREVENTIVE MAINTENANCE AND INSPECTIONS

NOTE: The safety level of the equipment can only be maintained if it is examined regularly for damage and wear.

Regularly:

- Clean surfaces on the frames and tubes from dust and dirt.
- Check that all bolts between parts, walls and floors are properly tightened, according to recommendations.
- Check equipment for sharp edges. Replace parts with sharp edges.

See also [www.eleiko.com](http://www.eleiko.com).

## SPARE PARTS AND SERVICE

The following components are parts that are not listed in the list of components section. They may however need to be replaced eventually. The rest of the components can be found in the list of components section.

Plastic Protection

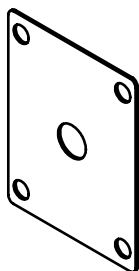

3085570 p6

Plastic Roller

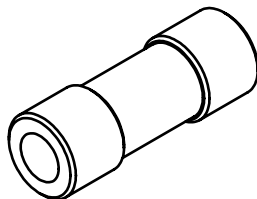

3085570 p38

Spring



2001445

Locking Nut M10



2001624

Plunger Pin

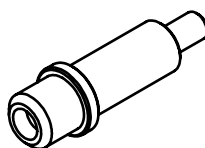

3085466 p17

Knurled Knob

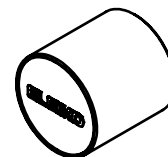

2001345

Contact Eleiko for spare parts and service:

Eleiko Group AB | Klastorpsvägen 18 | SE-302 62 HALMSTAD | Sweden  
E-mail: [info@eleiko.com](mailto:info@eleiko.com) | Phone: +46 35 17 70 70  
[www.eleiko.com](http://www.eleiko.com)

## WARRANTY

All products manufactured by ELEIKO are warranted to the original purchaser to be free from defects in workmanship and / or materials under normal use or service as follows:

- 5 years on structural moving parts.
- 3 years on bearing, bushings and pulleys.
- 1 year on cable and accessories.





# ELEIKO

Eleiko Group AB | Klastorpsvägen 18 | SE-302 62 HALMSTAD | Sweden  
E-mail: [info@eleiko.com](mailto:info@eleiko.com) | Phone: +46 35 17 70 70

[www.eleiko.com](http://www.eleiko.com)