

ELEIKO XF OUTDOOR FLAT BENCH

Art.no. 3002511-01

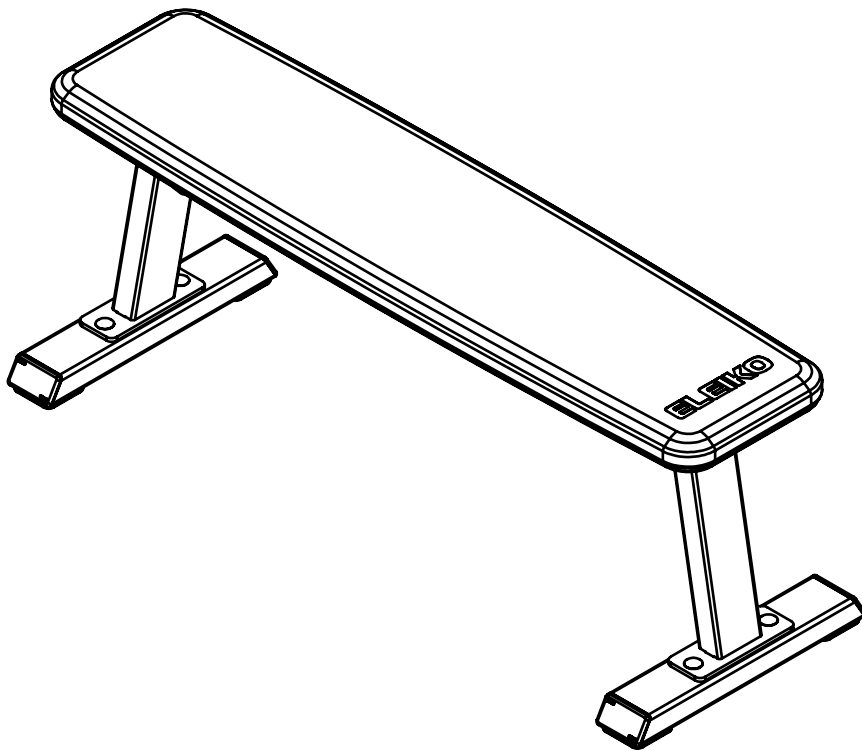

ELEIKO

CONTENTS

Read before installation and use	3
Safety instructions	3
List of components	4
Assembly instructions	5
Tools needed	5
User guide	8
Purpose	8
General instructions for use	8
Product specifications	8
Care and maintenance	9
Preventive maintenance and inspections	9
Spare parts and service	9
Warranty	9

READ BEFORE INSTALLATION AND USE

Install and use this equipment in a place where access and supervision are specifically controlled by the owner.

Be sure to install the equipment on a stable base and level the equipment properly. Eleiko recommends that all equipment is installed by a licensed contractor or an Eleiko installer.

SAFETY INSTRUCTIONS

It is the responsibility of the purchaser of ELEIKO products to instruct all users and supervising personnel on proper usage of the equipment.

1. All included warnings (labels) and instructions **MUST** be read before the use of any Eleiko equipment. Only use the equipment as it is intended.
2. A user **MUST** get a medical examination and proper instructions before using any Eleiko equipment.
3. **DO NOT** let anyone, under any circumstances, use equipment that appears to be damaged. Do not try to repair any equipment before consulting an Eleiko technician.
4. **DO NOT** replace components of Eleiko equipment with other, none Eleiko, equipment (magnetic safety pin, frames, bars etc.). Do not improvise! If there are any doubts, consult an Eleiko representative prior to any intervention.
5. **DO NOT** overload the equipment and **DO NOT** try to exceed personal strength levels.
6. Children under the age of 14 must be supervised by an adult.
7. **DO NOT** remove any safety labels from the Eleiko equipment. Eleiko is not responsible if a label is removed. Replace damaged labels immediately.
8. Eleiko packaging for products can be made of wood. Be aware of splinters! You **MUST** use protective gloves and proper work wear.
9. Eleiko packaging material could be a risk when handling. Be aware of crushing! You **MUST** use work wear including protective gloves and hard shoes.
10. Eleiko products and packing material are heavy, You **MUST** use proper lifting techniques, work wear and hard shoes.

LIST OF COMPONENTS

1x

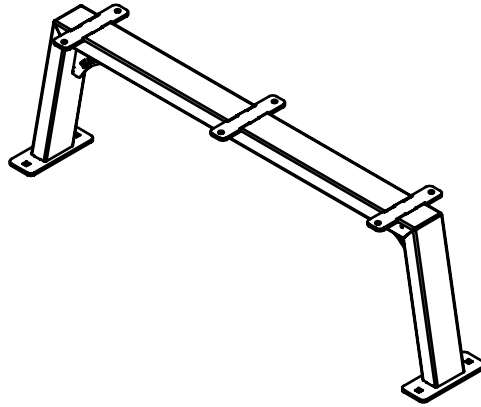

3002511 a1

1x

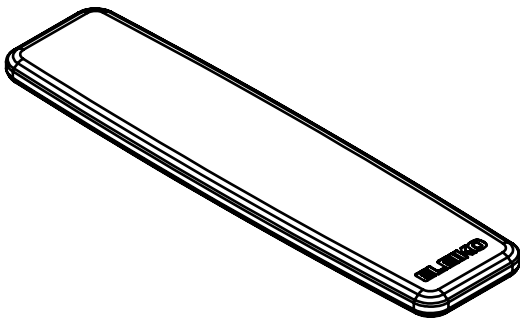

2001908

2x

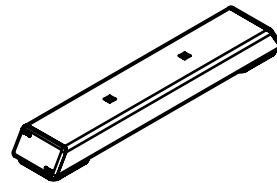

3002511 a4

6x



K6S M10 x 20
2001671-L20

4x

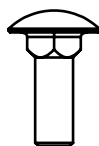

CARRIAGE BOLT M10 x 30
2001672-L30

4x



2001673

4x



2001674

ASSEMBLY INSTRUCTIONS

Before assembly, make sure you have enough clearance on all sides of the equipment, not less than 0,6 meters. Take in account the accessibility to remove and replace bar and weights.

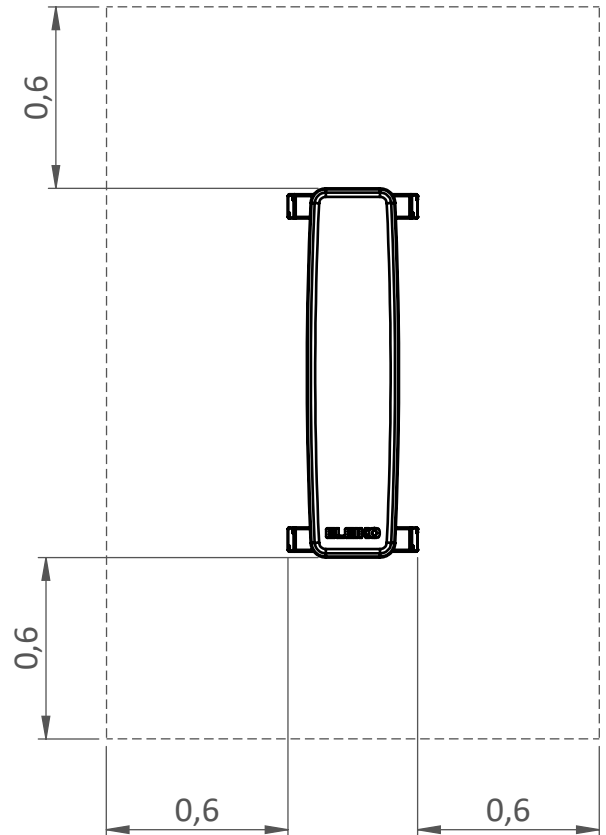

TOOLS NEEDED

You need the following tools to assemble the equipment.

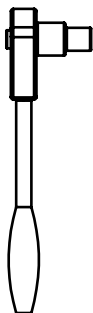

Socket Wrench Size 17mm

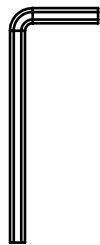

Allen Key Size 6

NOTE: Do not use electric power tools for assembly.

1.

1x

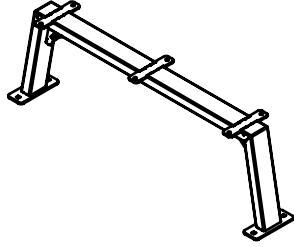

3002511 a1

1x

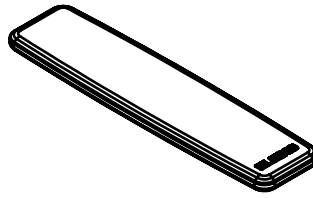

2001908

6x



K6S M10 x20

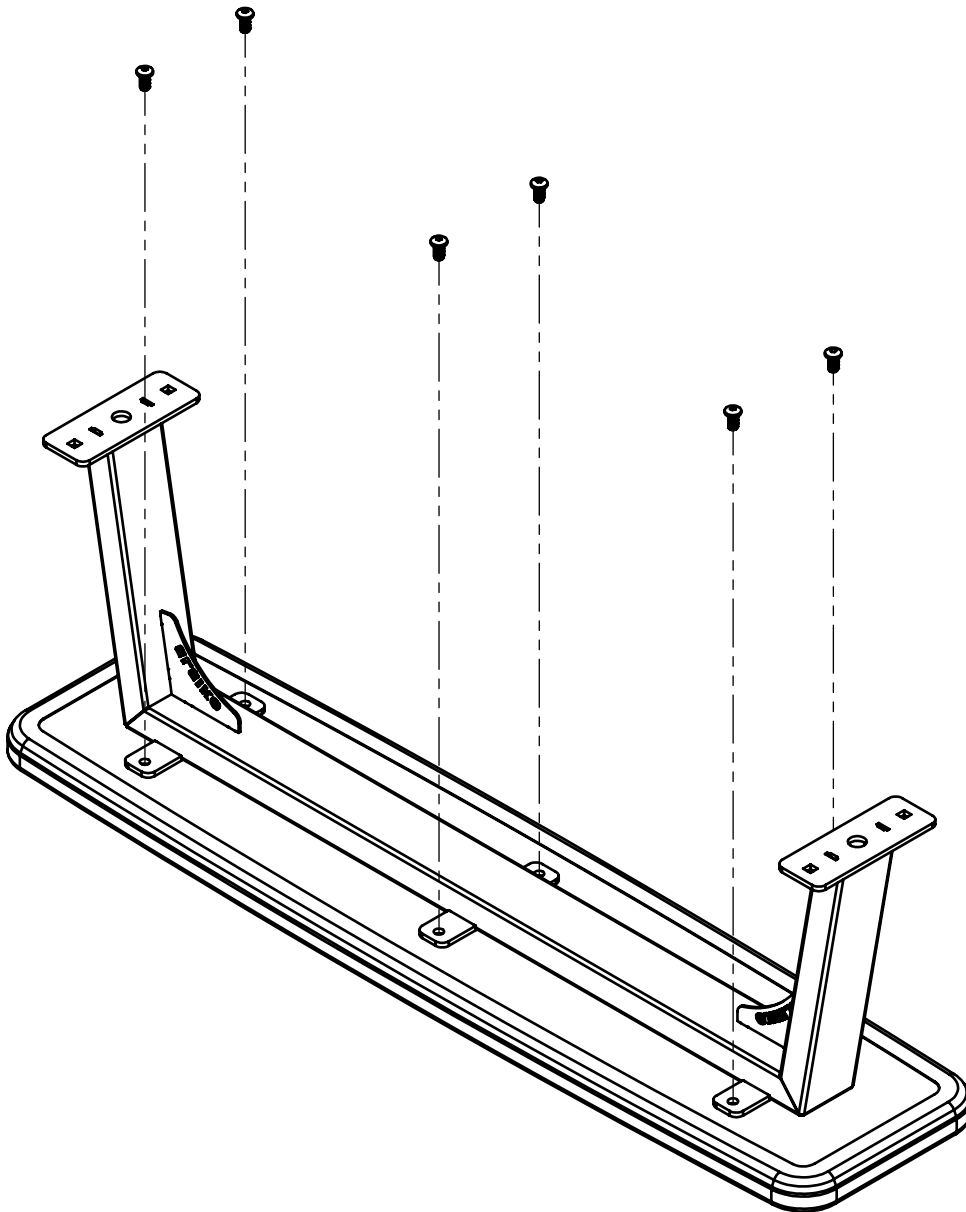

2.

2x

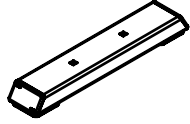

3002511 a2

4x



CARRIAGE BOLT M10 x 30

4x



2001673

4x



2001674

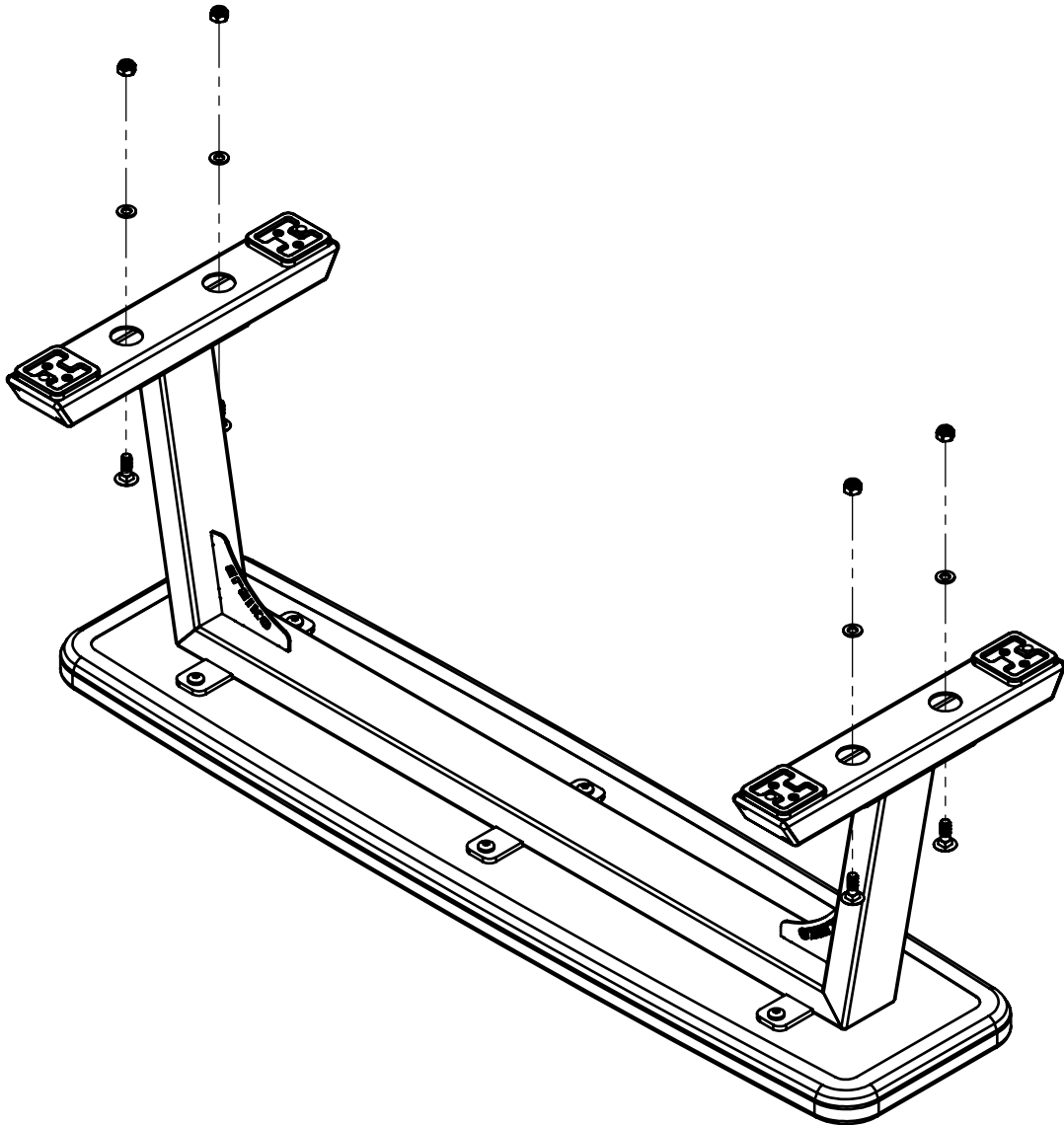

USER GUIDE

PURPOSE

Flat bench with a small footprint that can be used for a variety of free weight training exercises.

PRODUCT SPECIFICATION

Max user weight	150 kg / 330 lbs
Max training weight	350 kg / 771 lbs
Product weight	19,5 kg / 43 lbs
Dimensions (L x W x H)	1220 x 430 x 456 mm 48 x 17 x 18"

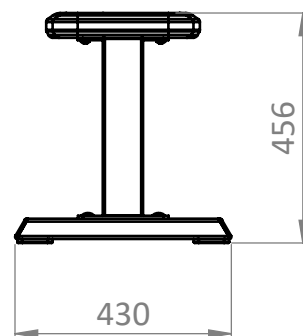
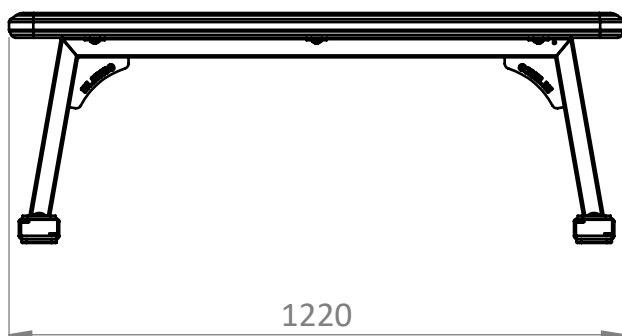

CARE AND MAINTENANCE

PREVENTIVE MAINTENANCE AND INSPECTIONS

NOTE: The safety level of the equipment can only be maintained if it is examined regularly for damage and wear.

Daily:

- Cleaning of upholstery.

Regularly:

- Clean surfaces on the frames and tubes from dust and dirt.
- Check that all bolts between parts, walls and floors are properly tightened, according to recommendations.
- Check equipment for sharp edges. Replace parts with sharp edges.
- Check equipment structural frames and welds to ensure they are free from cracks, irregularities or any other abnormalities. If in doubt, consult an Eleiko representative before product use.

Cleaning and Care:

- Apply a mild soap detergent to a lint free cloth, then wipe down product surface.
- While it is safe to use an alcohol-based neutral pH7 solution on surface-treated steel elements of the benches and racks, take care to avoid pads and cushions.
- We recommend alcohol-free, bleach-free, and o-phenylphenol (OPP) ammonia-free wipes.

See also www.eleiko.com.

SPARE PARTS AND SERVICE

Contact Eleiko for spare parts and service:

Eleiko Group AB | Klastorpsvägen 18 | SE-302 62 HALMSTAD | Sweden
E-mail: info@eleiko.com | Phone: +46 35 17 70 70
www.eleiko.com

WARRANTY

All products manufactured by ELEIKO are warranted to the original purchaser to be free from defects in workmanship and / or materials under normal use or service as follows:

- 10 years on structural frame welds (NOT on moving parts).
- 1 year on wear and tear parts.
- 6 months on polyurethane upholstery.

Normal wear and tear do not fall under the warranty.

ELEIKO

Eleiko Group AB | Klastorpsvägen 18 | SE-302 62 HALMSTAD | Sweden
E-mail: info@eleiko.com | Phone: +46 35 17 70 70

www.eleiko.com