

ELEIKO PRESTERA CABLE ATTACHMENT

Art.no. 3085601, 3085709, 3085850

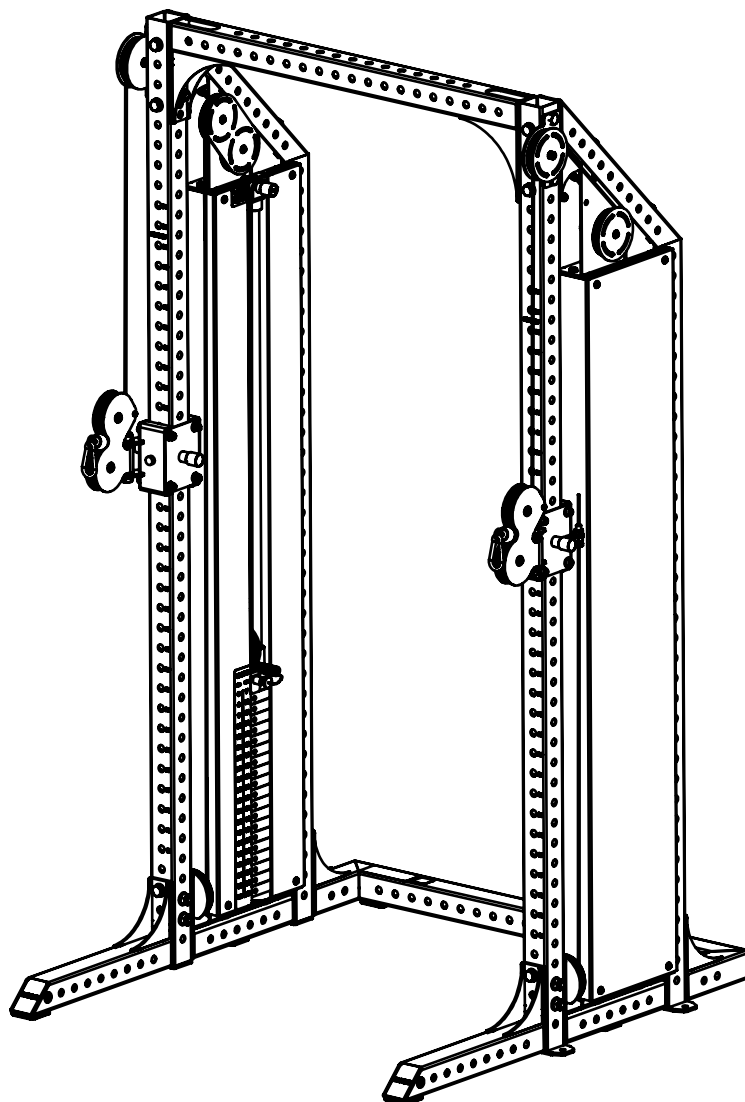

ELEIKO

CONTENTS

Read before installation and use	3
Safety instructions	3
Warning labels	4
Assembly instructions - General	5
Tools needed	5
Assembly instructions - Left side	6
List of components	7-10
Assembly instructions - Right side	35
List of components	36-39
User guide	64
Purpose	64
General instructions for use	64
Product specifications	64
Care and maintenance	65
Preventive maintenance and inspections	65
Spare parts and service	65
Warranty	65

READ BEFORE INSTALLATION AND USE

Install and use this equipment in a place where access and supervision are specifically controlled by the owner.

Be sure to install the equipment on a stable base and level the equipment properly. Eleiko recommends that all equipment is installed by a licensed contractor or an Eleiko installer.

This equipment is intended for indoor use only.

SAFETY INSTRUCTIONS

It is the responsibility of the purchaser of ELEIKO products to instruct all users and supervising personnel on proper usage of the equipment. It is also the responsibility of the purchaser of ELEIKO products to assess the suitability of the floor, and to choose appropriate fasteners depending on floor type when using ELEIKO products that needs to be bolted to the ground.

1. All included warnings (labels) and instructions MUST be read before the use of any Eleiko equipment. Only use the equipment as it is intended.
2. A user MUST get a medical examination and proper instructions before using any Eleiko equipment.
3. DO NOT let anyone, under any circumstances, use equipment that appears to be damaged. Do not try to repair any equipment before consulting an Eleiko technician.
4. DO NOT replace components of Eleiko equipment with other, none Eleiko, equipment (magnetic safety pin, frames, bars etc.). Do not improvise! If there are any doubts, consult an Eleiko representative prior to any intervention.
5. DO NOT overload the equipment and DO NOT try to exceed personal strength levels.
6. Children under the age of 14 must be supervised by an adult.
7. DO NOT remove any safety labels from the Eleiko equipment. Eleiko is not responsible if a label is removed. Replace damaged labels immediately.
8. Eleiko packaging for products can be made of wood. Be aware of splinters! You MUST use protective gloves and proper work wear.
9. Eleiko packaging material could be a risk when handling. Be aware of crushing! You MUST use work wear including protective gloves and hard shoes.
10. Eleiko products and packing material are heavy, You MUST use proper lifting techniques, work wear and hard shoes.

WARNING LABELS



Pinch point

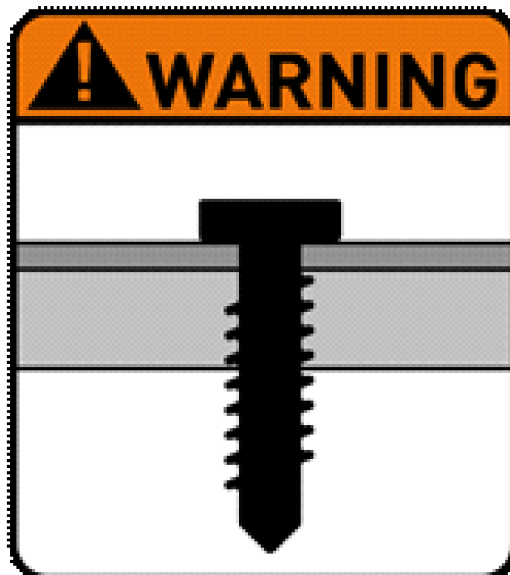

When using Eleiko Prestera Cable Attachment for Eleiko Prestera Tall Rack, the rack **MUST** be bolted to the ground!

ASSEMBLY INSTRUCTIONS

Before assembly, make sure you have enough clearance on all sides of the equipment, not less than 0,6 meters. Take in account the accessibility to remove and replace bar and weights.

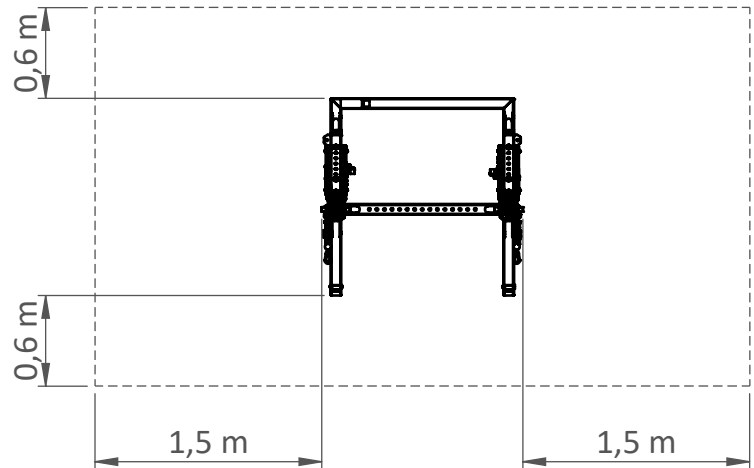

TOOLS NEEDED

You need the following tools to assemble the equipment.

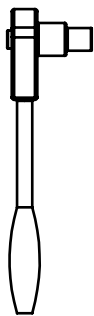

Socket Wrench Size 24mm



Wrench Size 24mm



Wrench Size 17mm

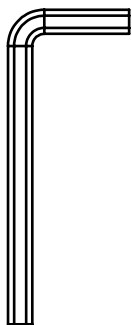

Allen Key Size 8

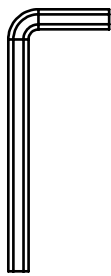

Allen Key Size 6

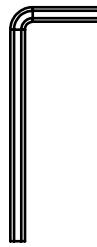

Allen Key Size 5



Allen Key Size 4

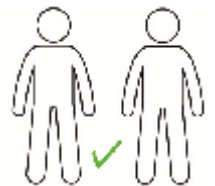

NOTE: Do not use electric power tools for assembly.

ASSEMBLY INSTRUCTIONS LEFT SIDE

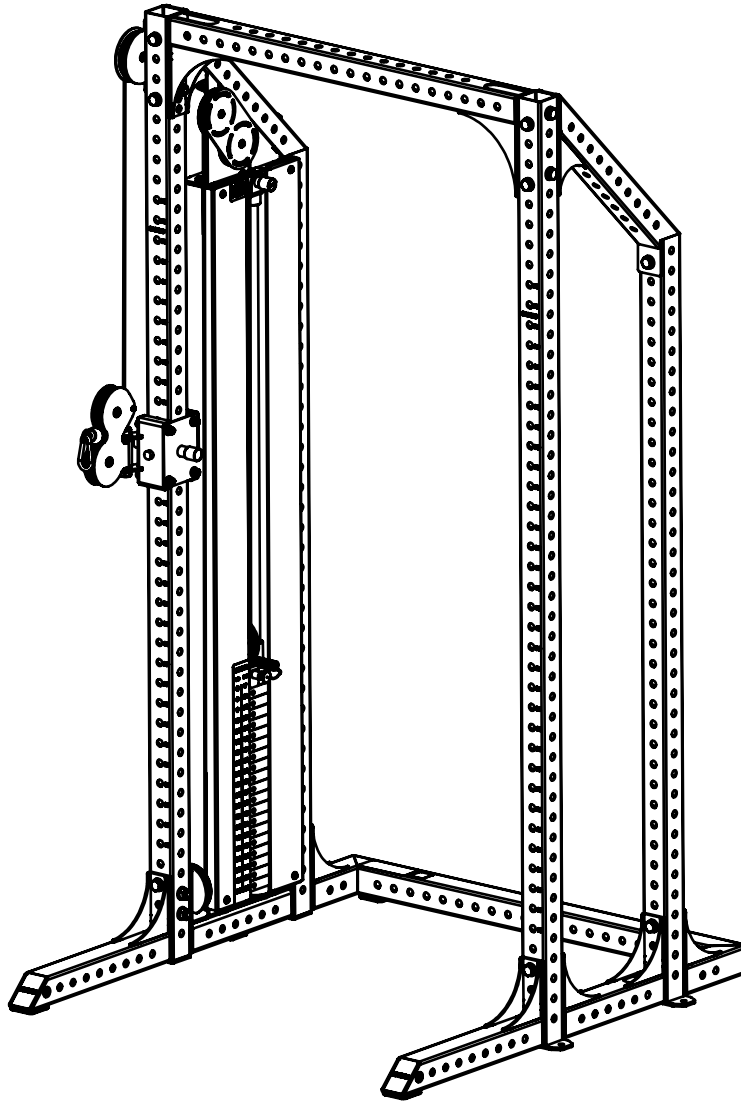

ASSEMBLY INSTRUCTIONS FOR THE RIGHT SIDE CAN BE FOUND ON
PAGE 35





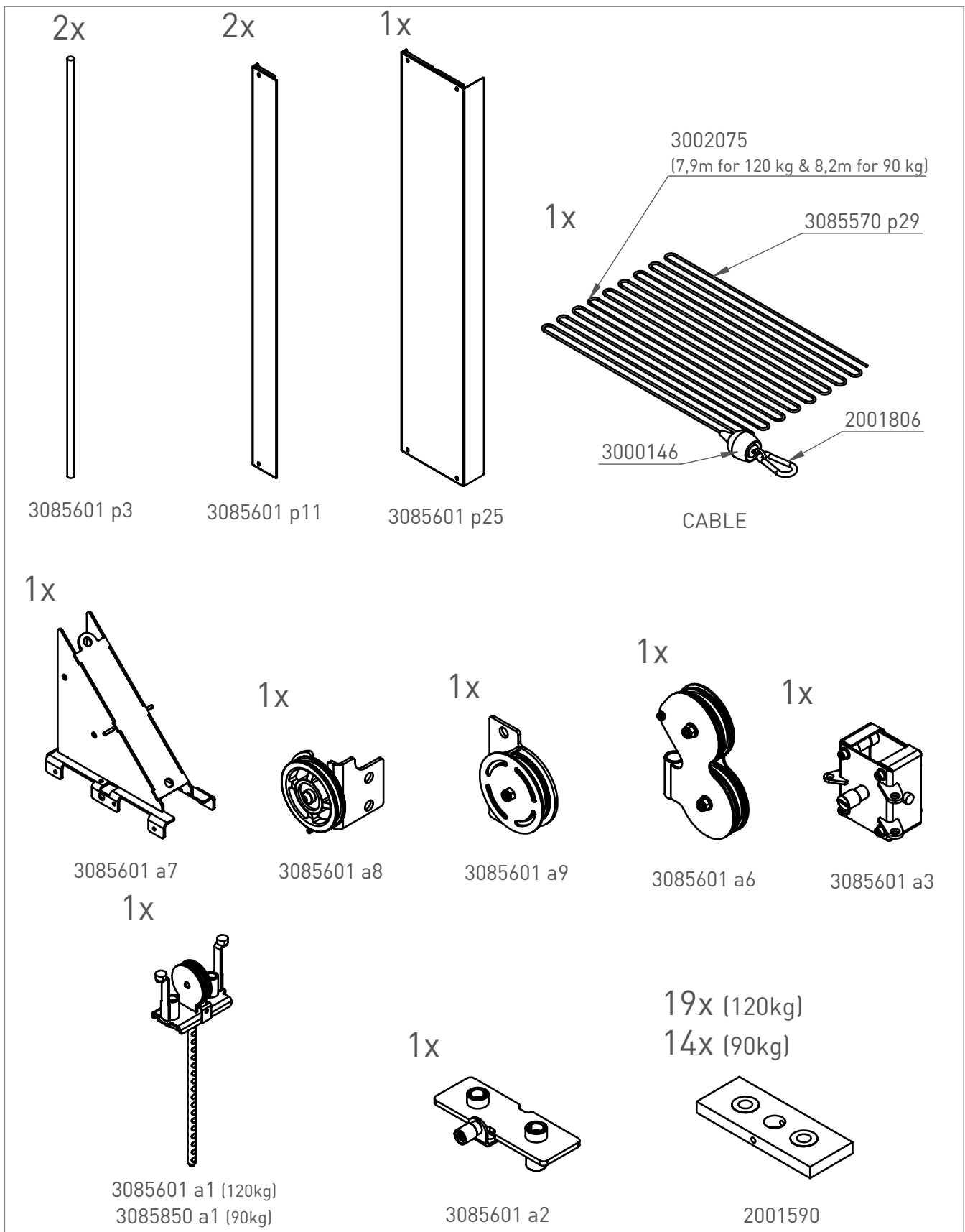





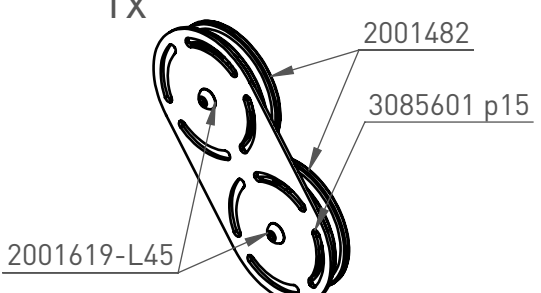
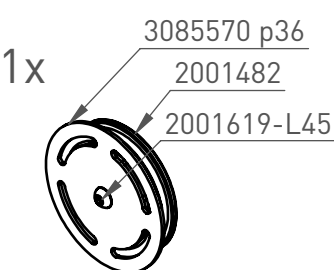
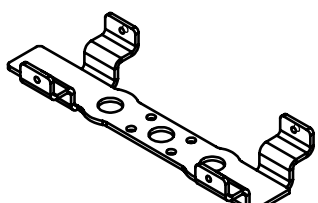
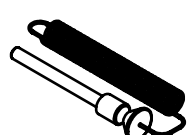
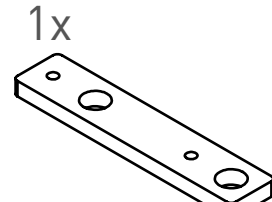

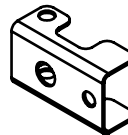

LIST OF COMPONENTS

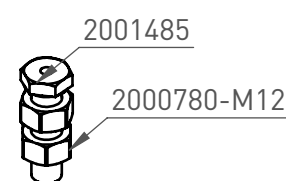
Eleiko Prestera Cable Attachment
 Art.no 3085601 (120kg) & 3085850 (90kg)

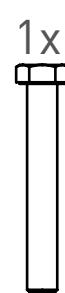

LIST OF COMPONENTS

Eleiko Pretera Cable Attachment
 Art.no 3085601 (120kg) & 3085850 (90kg)

<p>1x</p>  <p>2001482 3085601 p15 2001619-L45</p> <p>Double Wheel Kit</p>	<p>1x</p>  <p>3085570 p36 2001482 2001619-L45</p> <p>Single Wheel Kit</p>	<p>1x</p>  <p>3085601 p8</p>		
<p>1x</p>  <p>2001483</p>	<p>1x</p>  <p>3085601 p9</p>	<p>2x</p>  <p>3085570 p33</p>	<p>2x</p>  <p>3085570 p34</p>	
<p>1x</p>  <p>2001808</p>	<p>2x</p>  <p>2001000</p>	<p>1x</p>  <p>3085601 p6</p>	<p>8x</p>  <p>3061757 p30 USED FOR STORAGE PINS</p>	
<p>1x</p>  <p>2001485 2000780-M12</p> <p>Hollow Screw</p>	<p>2x</p>  <p>K6S M8 x 30 2000747-L30</p>	<p>14x</p>  <p>K6S M8 x 12 2001620-L12</p>	<p>16x</p>  <p>Washer M8 2001422</p>	
<p>1x</p>  <p>M16 x 110 2001385-L110</p>	<p>5x</p>  <p>M16 x 100 2001385-L100</p>	<p>10x</p>  <p>Washer M16 2001421</p>	<p>5x</p>  <p>Locking Nut M16 2001379</p>	<p>1x</p>  <p>Nut M16 2000780</p>





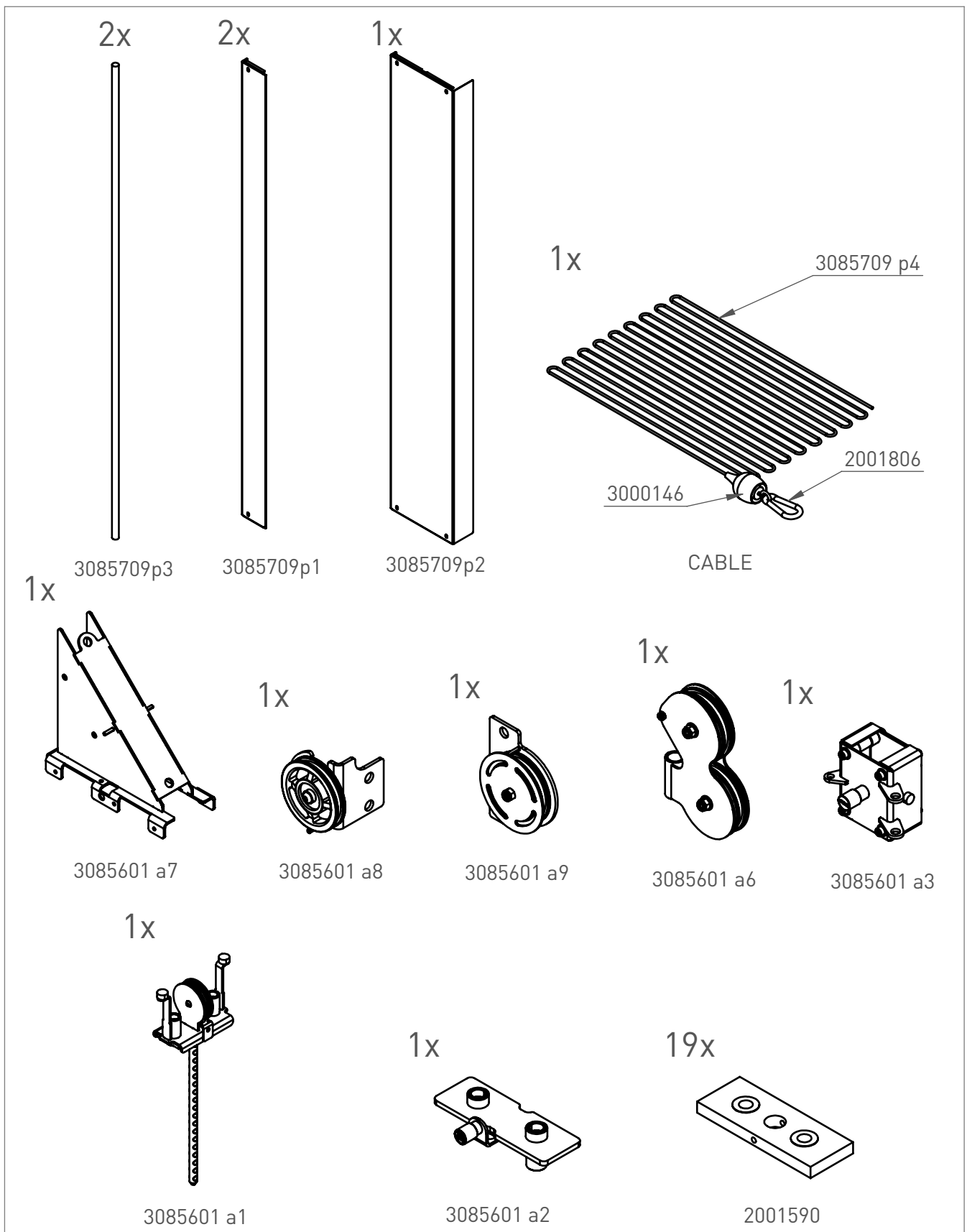





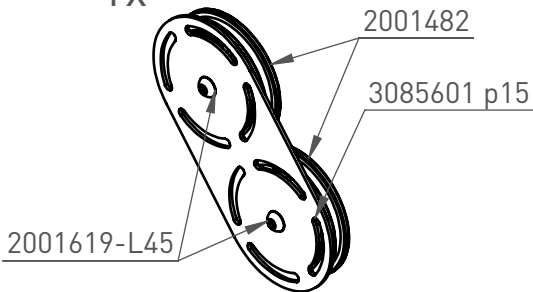
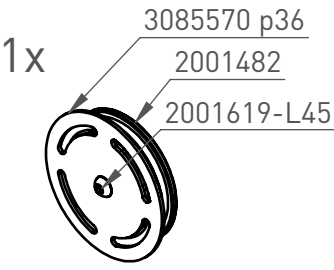
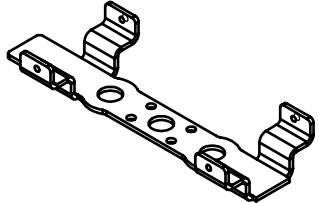
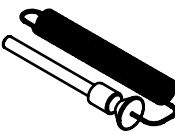
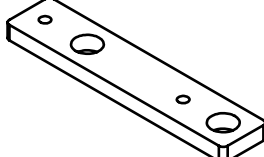

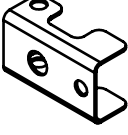

LIST OF COMPONENTS

Eleiko Pretera Cable Attachment - Tall Rack
Art.no 3085709

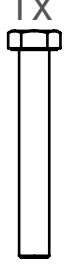

LIST OF COMPONENTS

Eleiko Pretera Cable Attachment - Tall Rack
Art.no 3085709

<p>1x</p>  <p>2001482 3085601 p15 2001619-L45</p> <p>Double Wheel Kit</p>	<p>1x</p>  <p>3085570 p36 2001482 2001619-L45</p> <p>Single Wheel Kit</p>	<p>1x</p>  <p>3085601 p8</p>		
<p>1x</p>  <p>2001483</p>	<p>1x</p>  <p>3085601 p9</p>	<p>2x</p>  <p>3085570 p33</p>	<p>2x</p>  <p>3085570 p34</p>	
<p>1x</p>  <p>2001808</p>	<p>2x</p>  <p>2001000</p>	<p>1x</p>  <p>3085601 p6</p>	<p>8x</p>  <p>3061757 p30 USED FOR STORAGE PINS</p>	
<p>1x</p>  <p>2001485 2000780-M12</p> <p>Hollow Screw</p>	<p>2x</p>  <p>K6S M8 x 30 2000747-L30</p>	<p>14x</p>  <p>K6S M8 x 12 2001620-L12</p>	<p>16x</p>  <p>Washer M8 2001422</p>	
<p>1x</p>  <p>M16 x 110 2001385-L110</p>	<p>5x</p>  <p>M16 x 100 2001385-L100</p>	<p>10x</p>  <p>Washer M16 2001421</p>	<p>5x</p>  <p>Locking Nut M16 2001379</p>	<p>1x</p>  <p>Nut M16 2000780</p>

PREPARATION

IF YOU HAVE ALSO PURCHASED A SVR
INSERT PLATFORM, INSTALL THE
PLATFORM FIRST!

BEFORE YOU START THIS ASSEMBLY,
REMOVE EVENTUAL GLIDING J-CUPS
AND/OR GLIDING SAFETY ARMS!

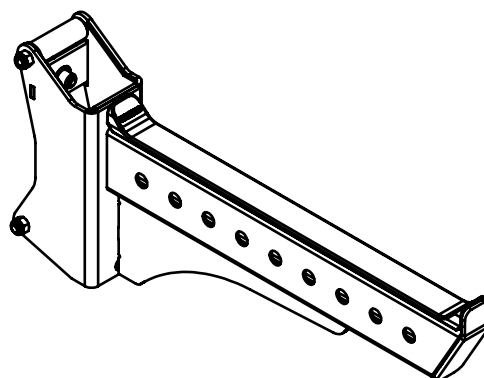
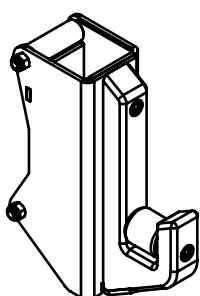

ALSO REMOVE THE RUBBER DAMPERS IF
YOU HAVE ELEIKO PRESTERA STORAGE
PINS, SAVE THESE FOR LATER!

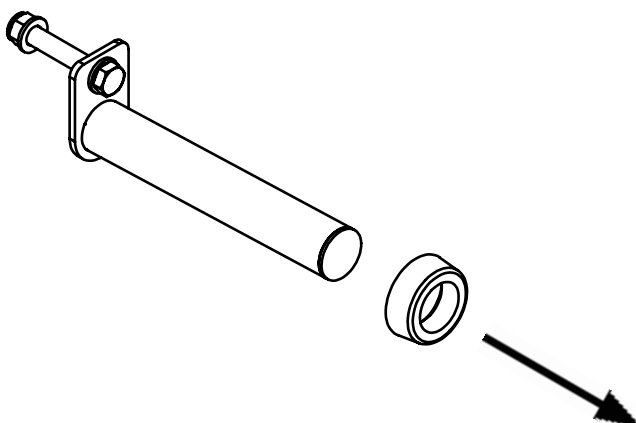

1.

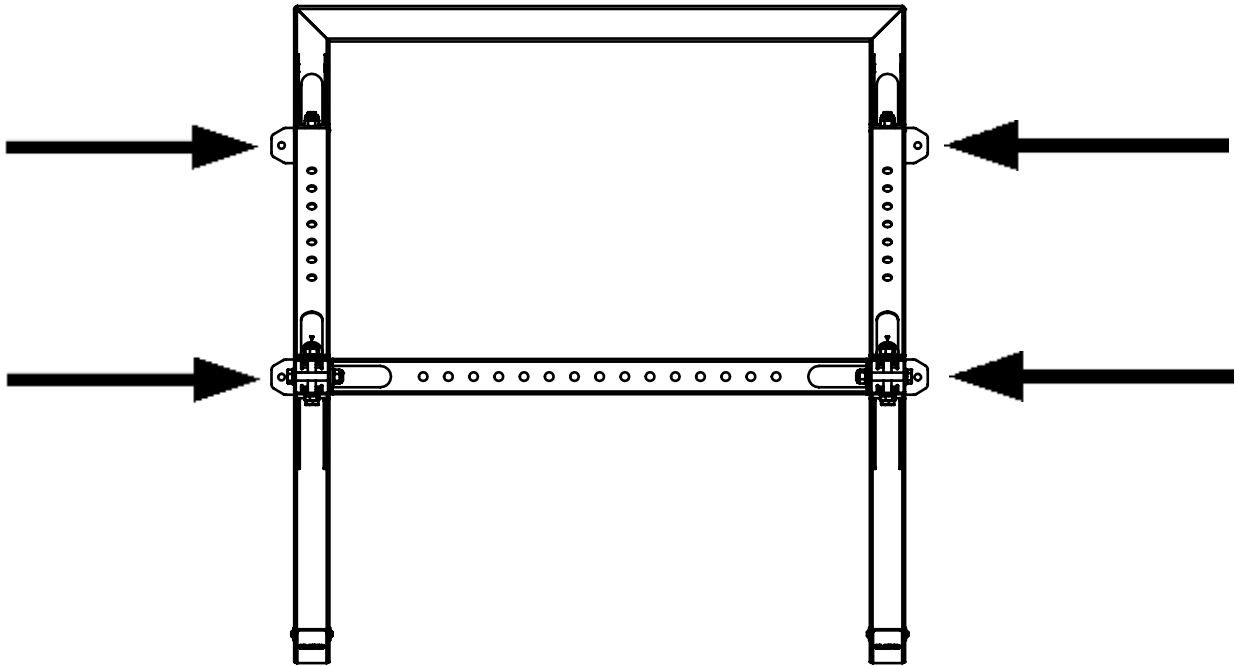

When using Eleiko Prestera Cable Attachment for Eleiko Prestera Tall Rack, the rack **MUST** be bolted to the ground!

2.

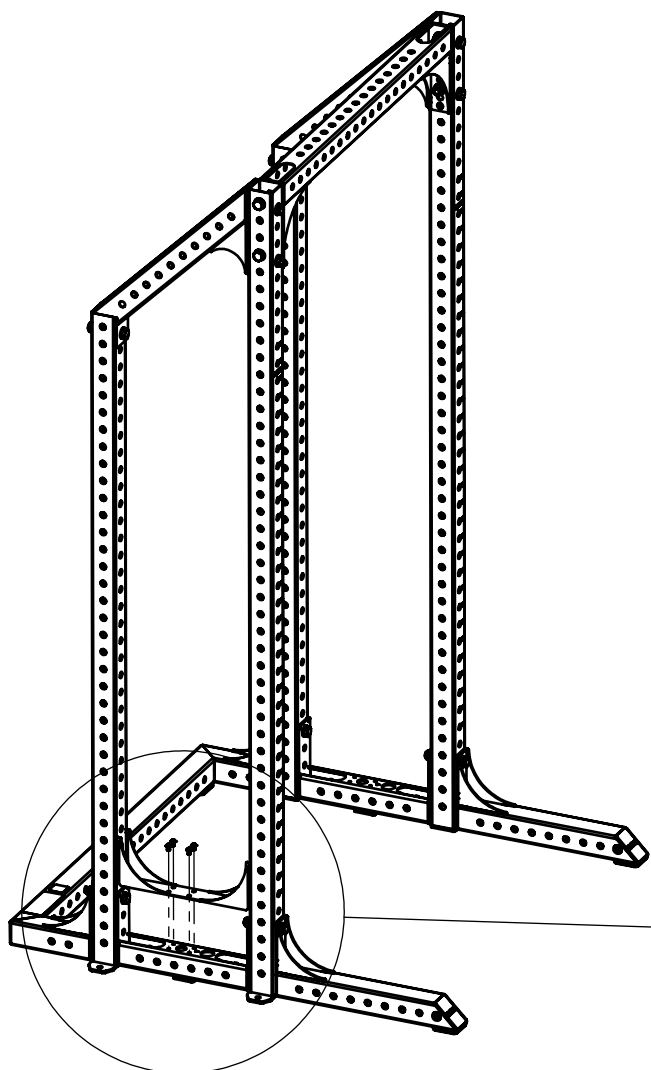

REMOVE TOP COVER PLATE!

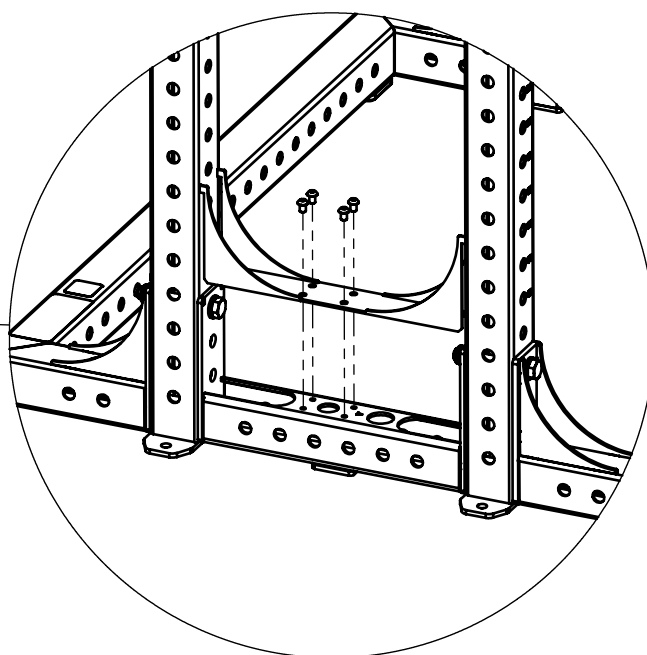

YOU WILL NOT NEED SCREWS AND COVER PLATE ANYMORE.
SAVE THE PARTS IN CASE YOU REMOVE THE CABLE ATTACHMENT IN THE FUTURE!

ONLY FOR DOUBLE HALF RACK
WITH TWO CABLE ATTACHMENTS, FRONT AND BACK

3.

1x

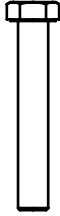

M16 x 100

1x



Nut M16

IF YOU HAVE A DOUBLE HALF RACK AND PLAN TO HAVE TWO CABLE
ATTACHMENTS, FRONT AND BACK, CHANGE THIS SCREW TO A M16x100.
ALSO REMOVE BOTH WASHERS AND REPLACE THE LOCKING NUT!

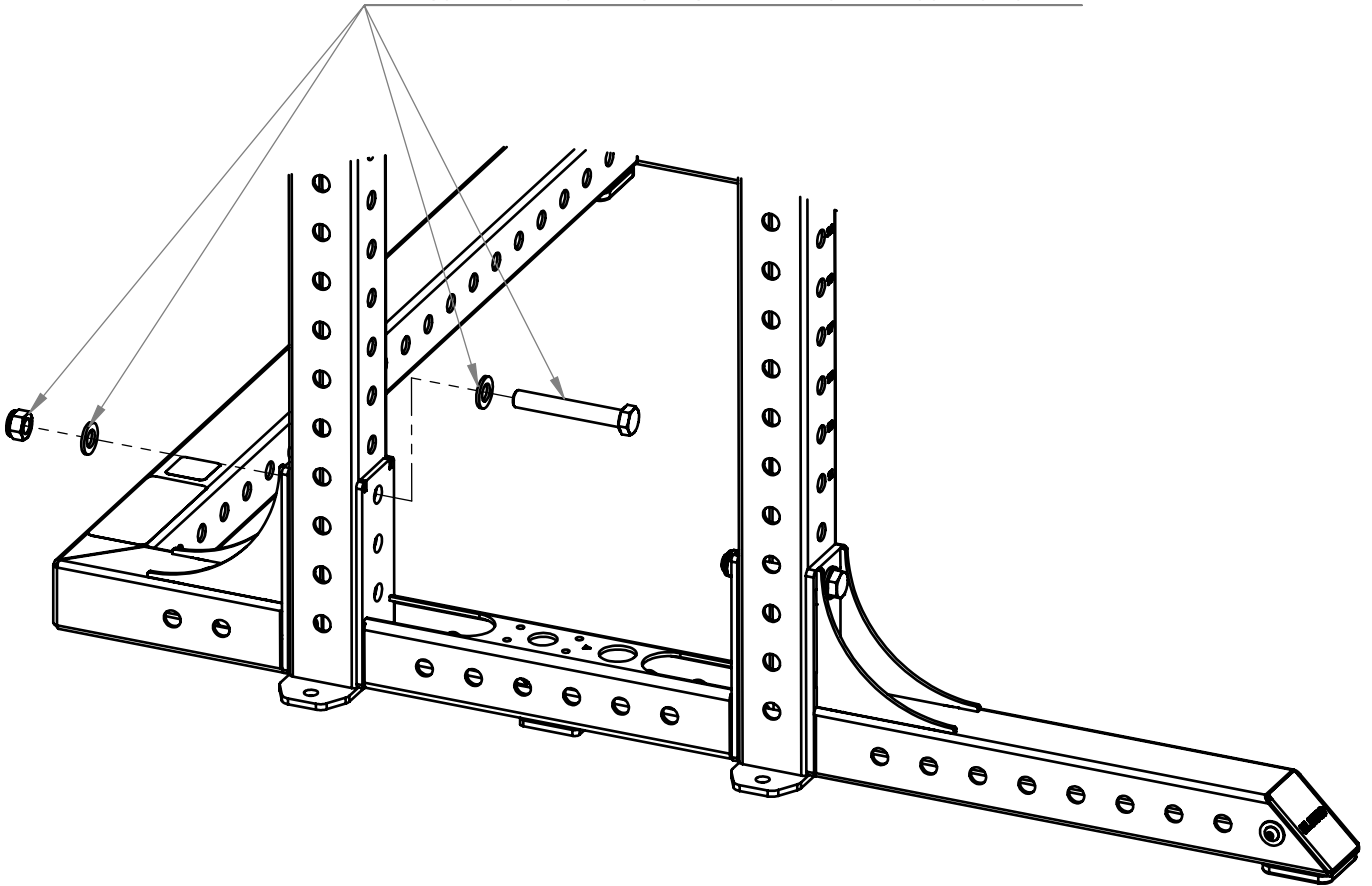

4.

1x

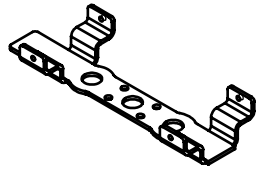

3085601 p8

4x



K65 M8 x 12

4x



Washer M8

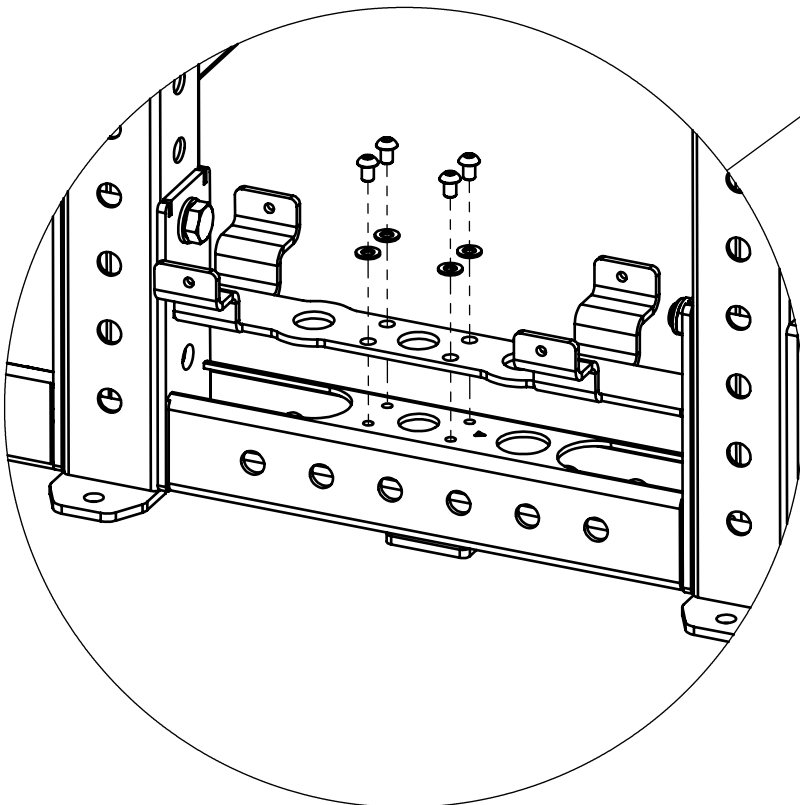
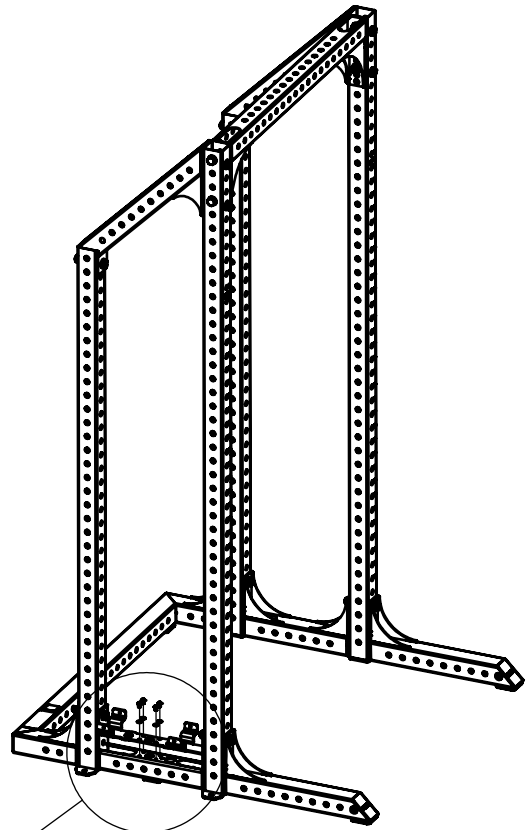

5.

1x

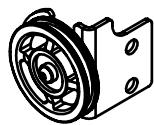

3085601 a8

2x

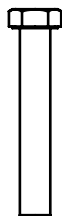

M16 x 100

4x



Washer M16

2x



Locking Nut M16

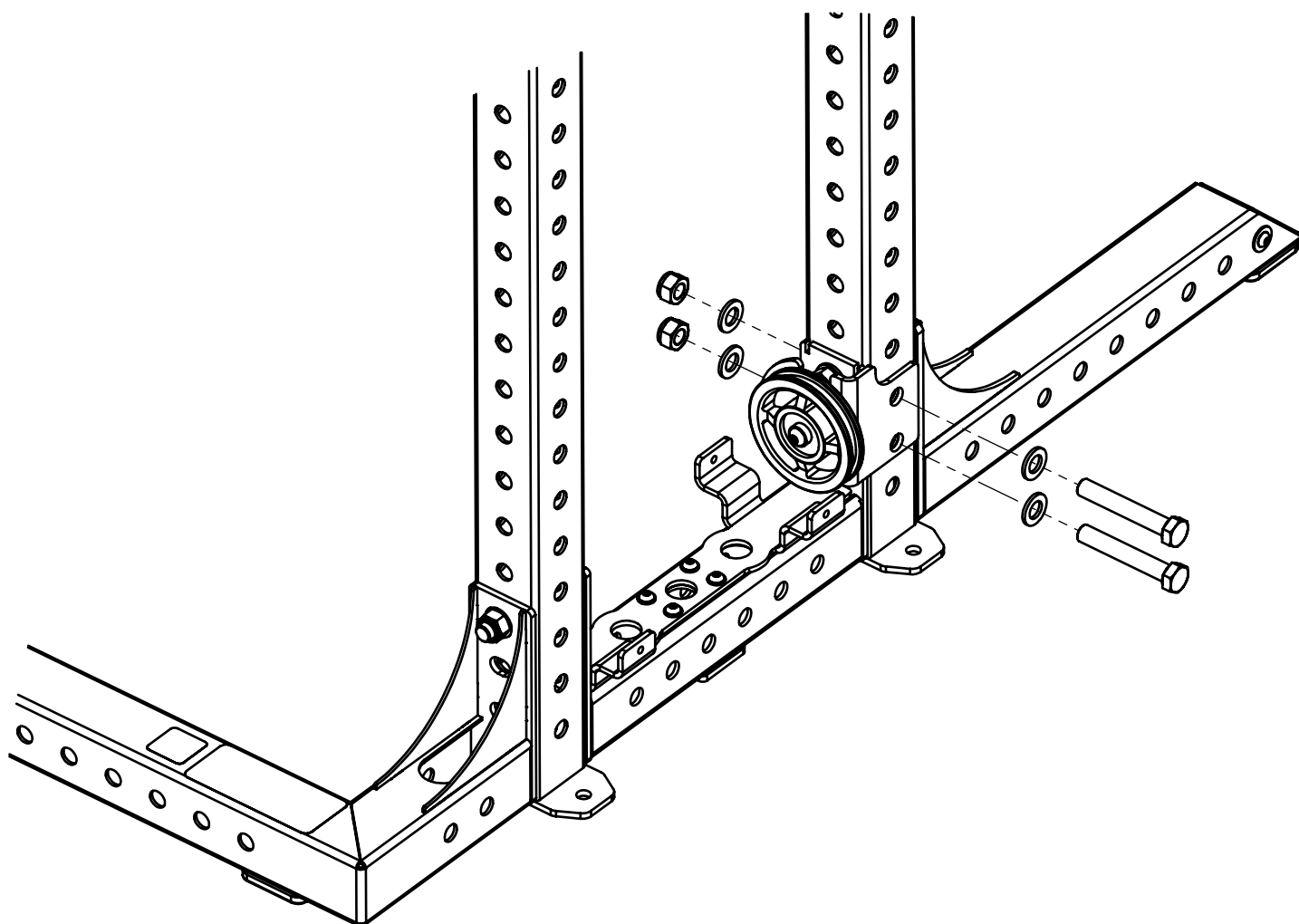

6.

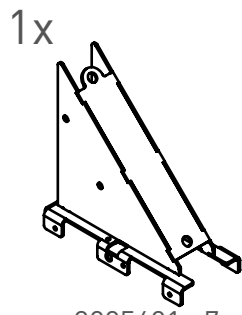

2x

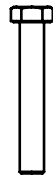

M16 x 100

4x



Washer M16

2x



Locking Nut M16

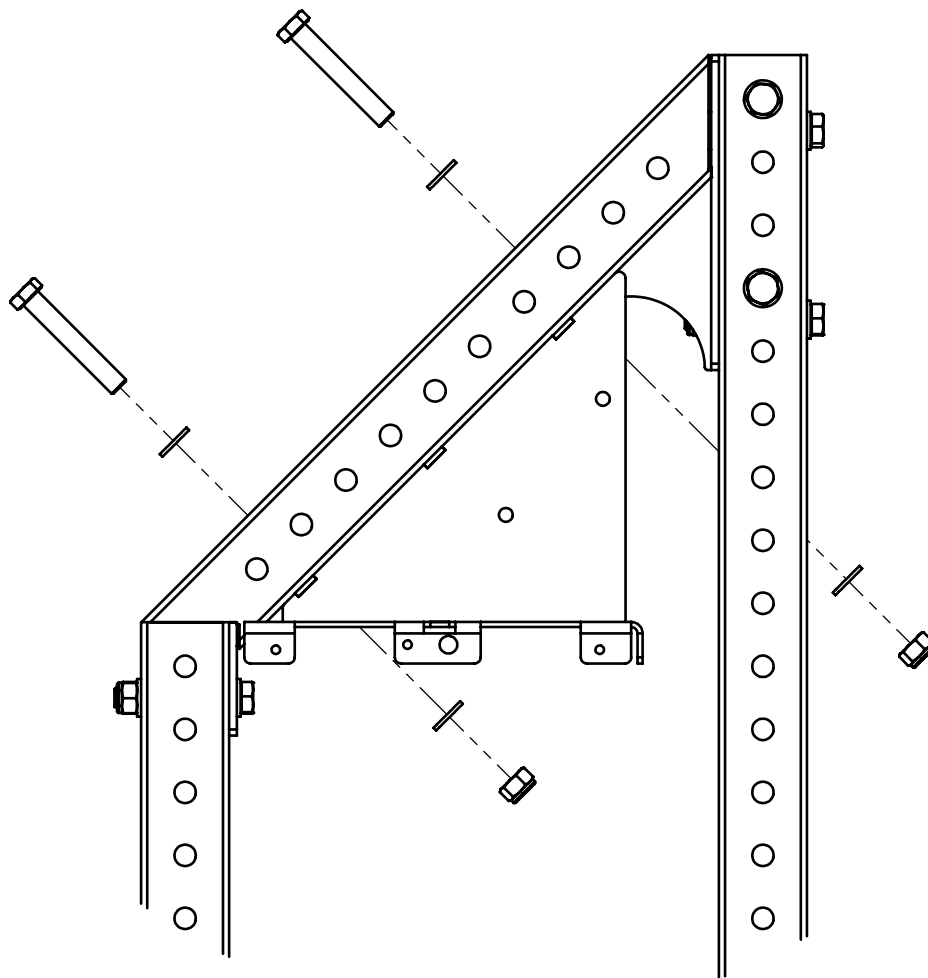

7.



3085601 p3 / 3085709 p3

2x



3085570 p33

2x



3085570 p34

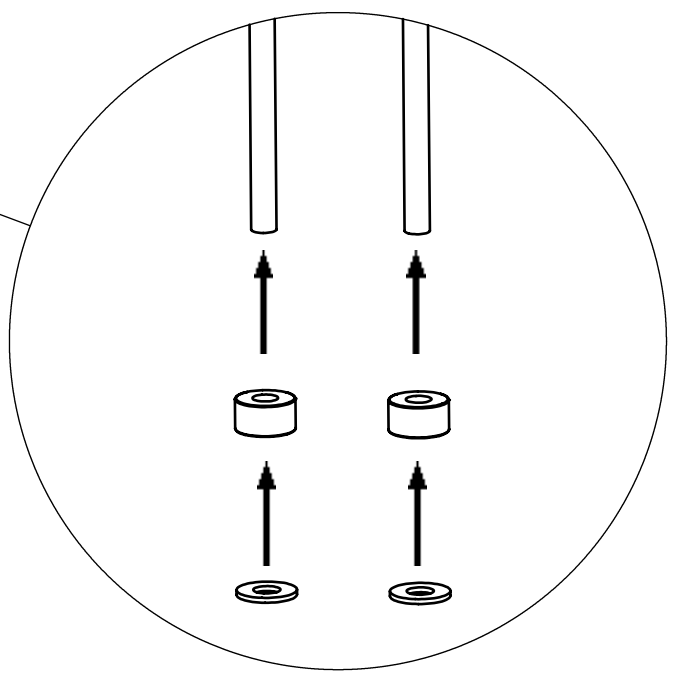
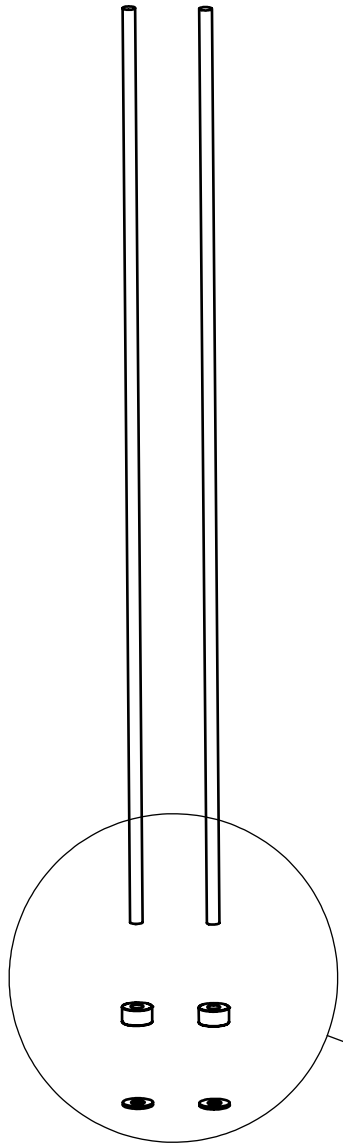

8.

PLACE RODS IN TILTED POSITION IN THESE HOLES.
RUBBER DAMPERS AND DISTANCE PLATES DOWN!

WIPE OFF BOTH RODS WITH A CLEAN CLOTH!

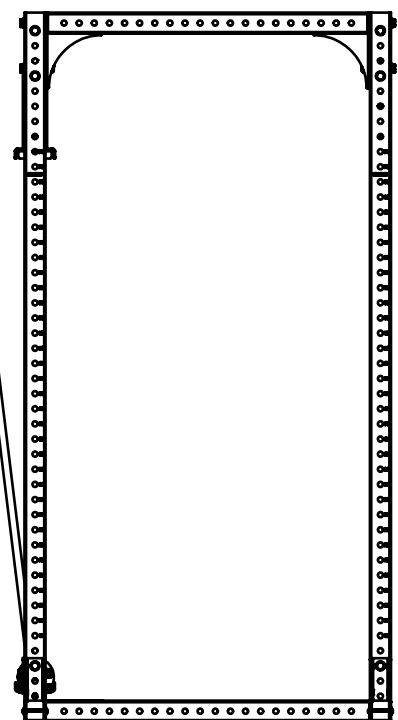
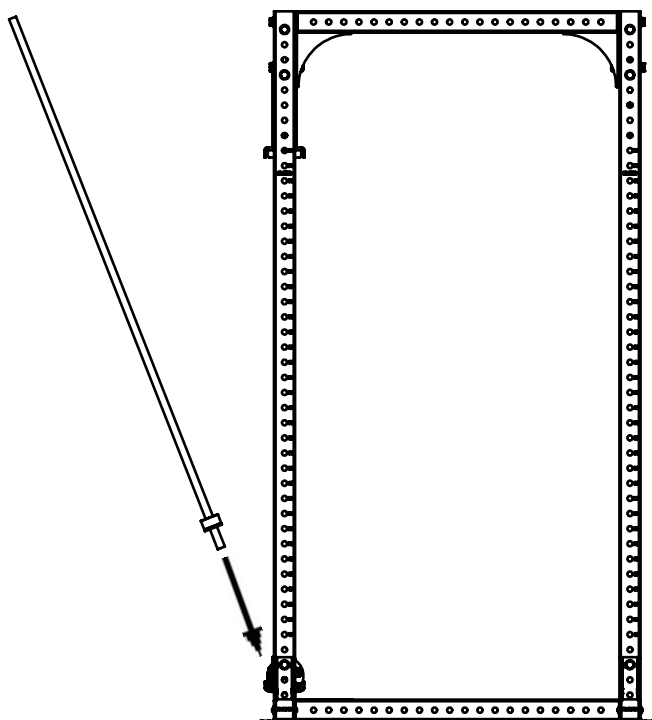
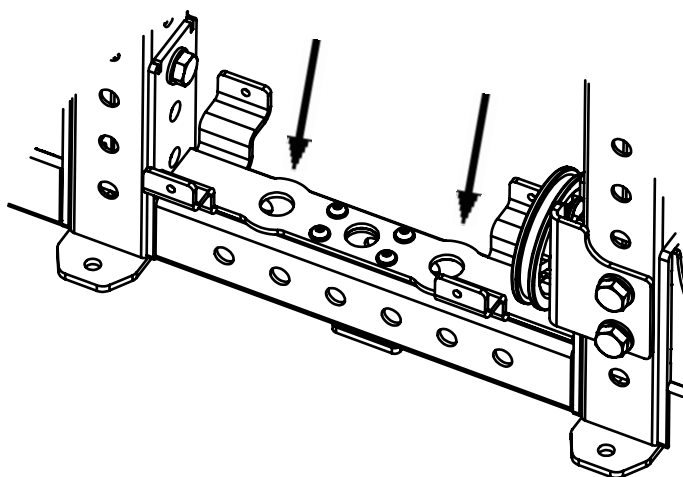

9.

19x / 14x

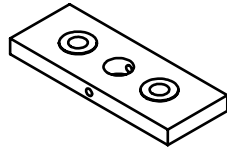

2001590

ASSEMBLE THE WEIGHT STACK PLATE BY PLATE!

MAKE SURE THE FIRST PLATE IS PUSHED ALL THE WAY DOWN AND LOCKED IN POSITION!

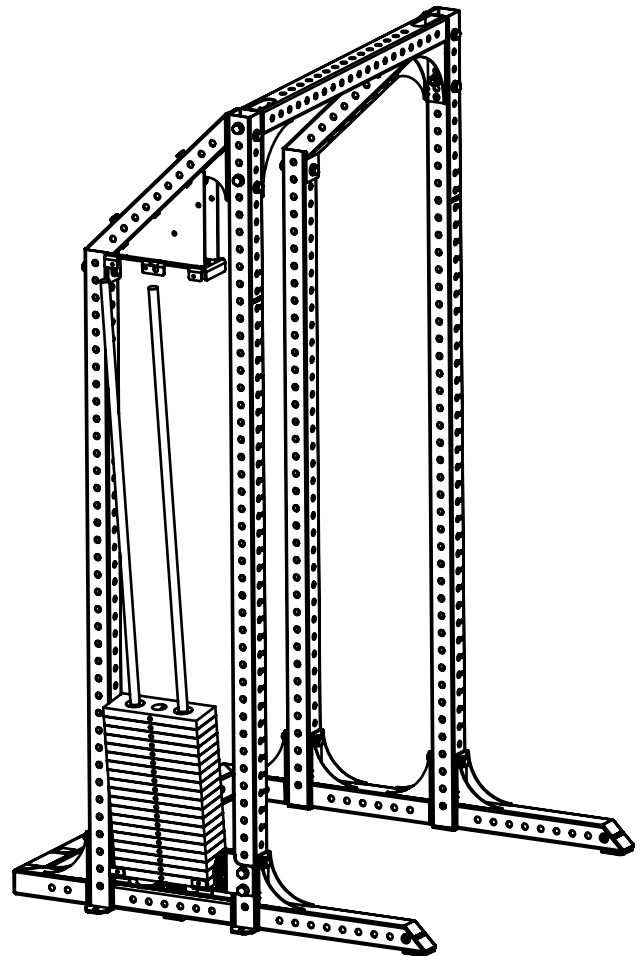
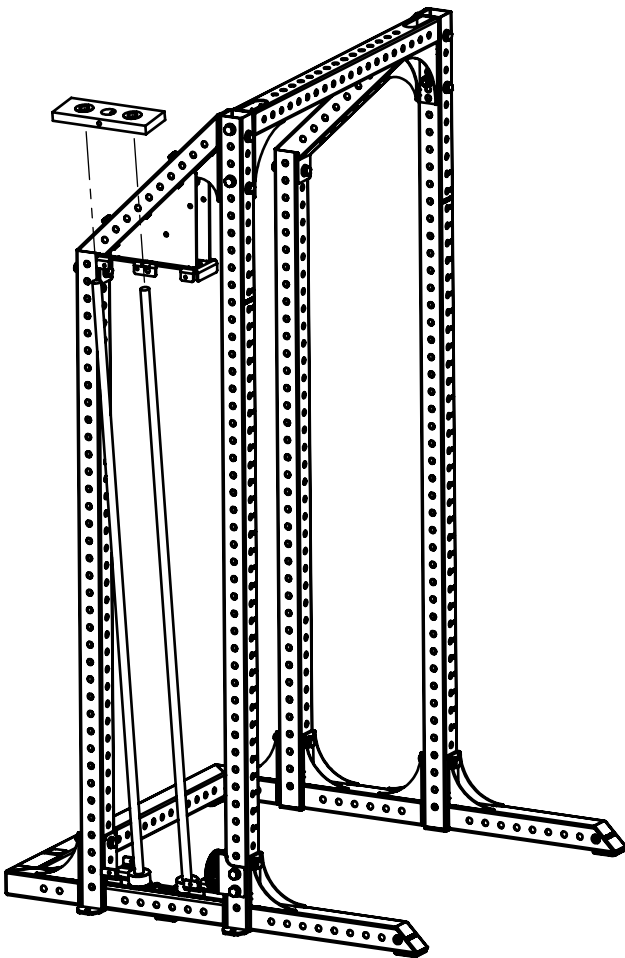

1x

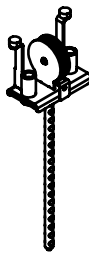

10.

3085601 a1 / 3085850 a1

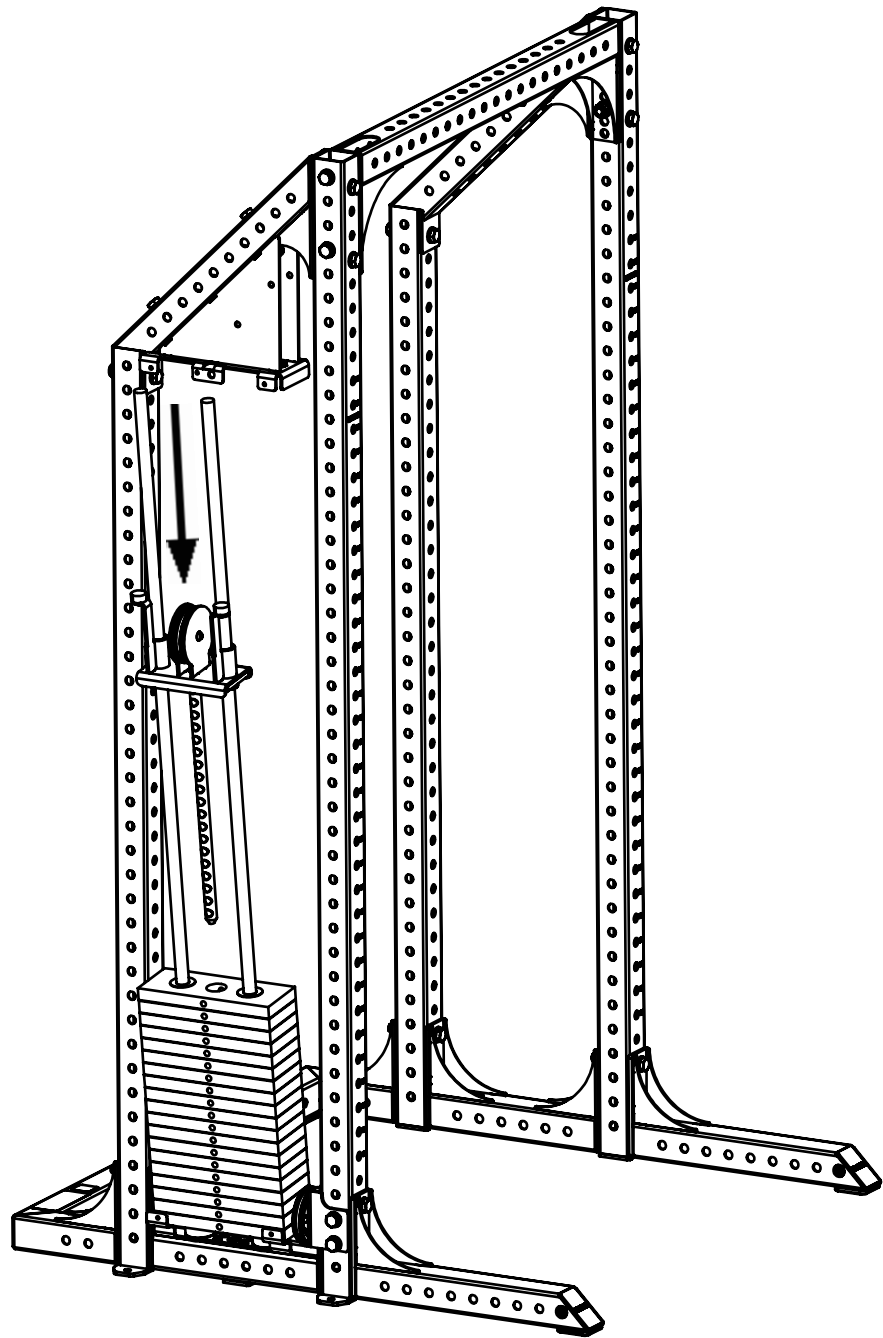

11.

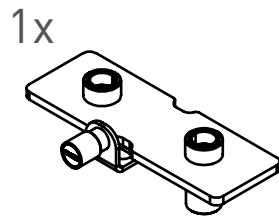

3085601 a2

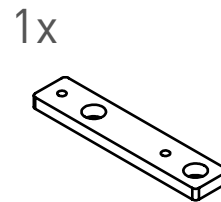

3085601 p9

MOUNT TOP WEIGHT AND PLASTIC TOP SUSPENSION!
PUSH TO VERTICAL POSITION!

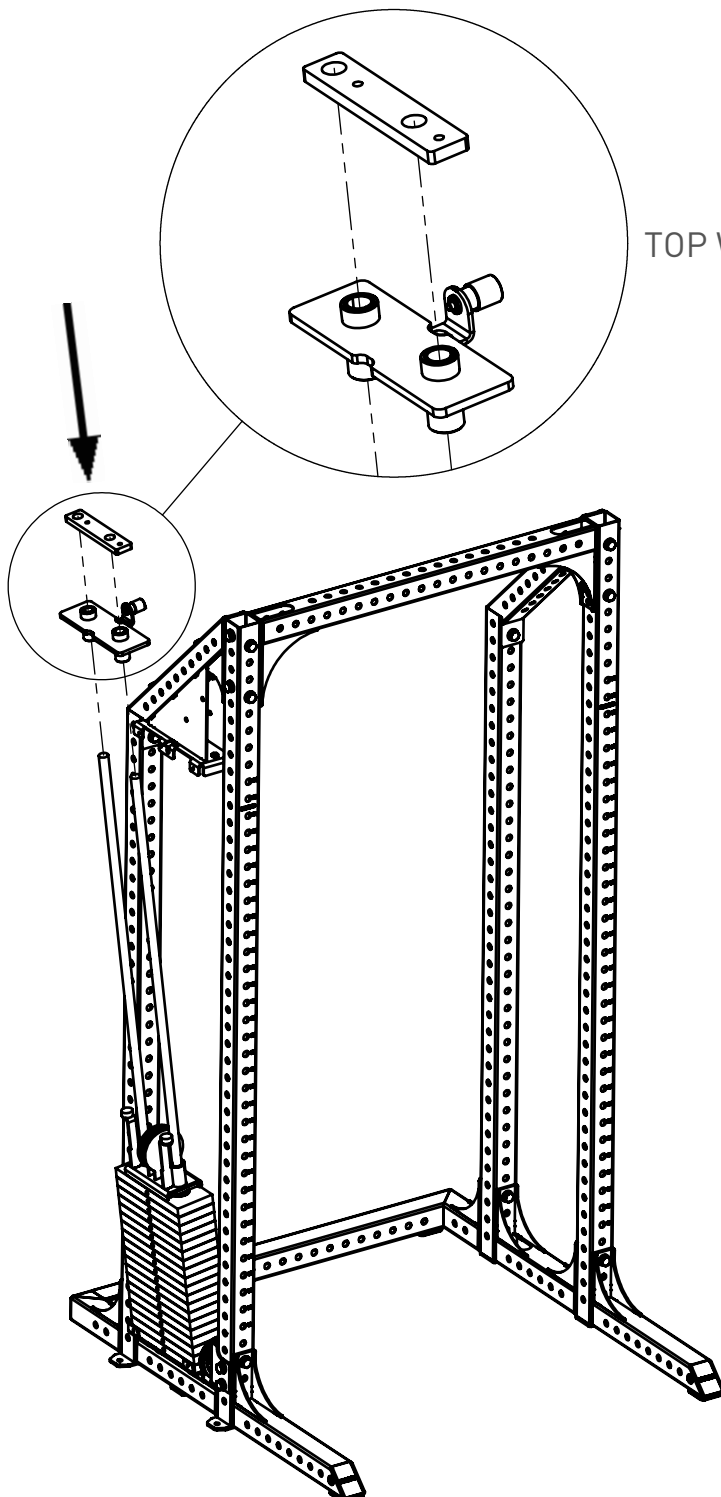

TOP WEIGHT AND PLASTIC TOP SUSPENSION
MUST BE TURNED THIS WAY!

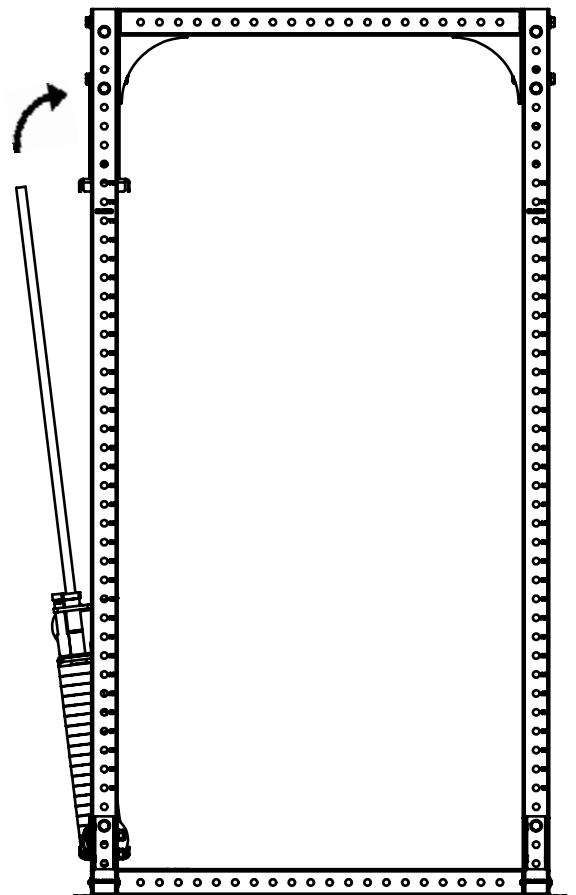

12.

1x

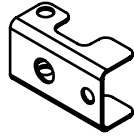

3085601 p6

2x



K6S M8 x 30

2x



K6S M8 x 12

4x



Washer M8

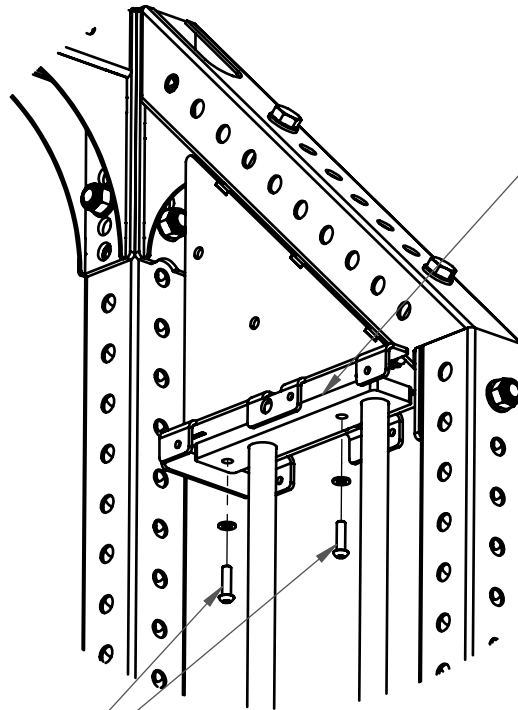

PLASTIC TOP SUSPENSION
FROM PREVIOUS STEP!

M8 x 30

3085601 p6

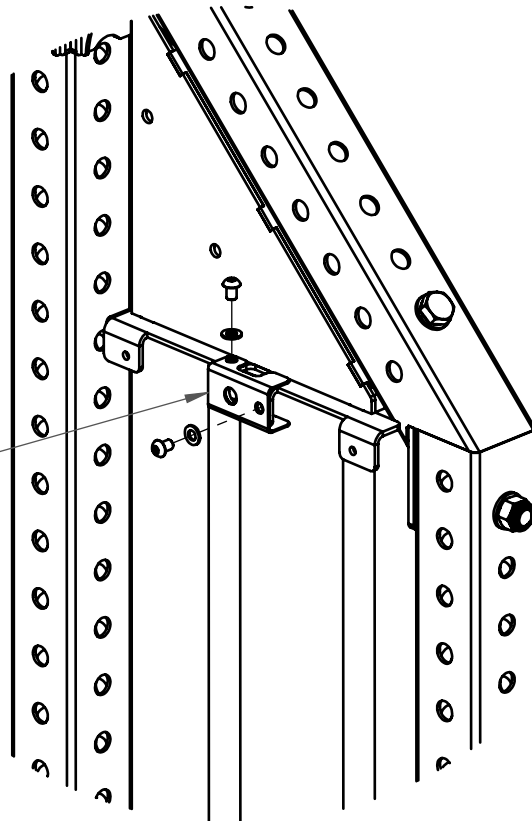

THE WEIGHT INCREMENT CAN NOW BE SECURED
IN A TOP POSITION WITH HELP OF THE POP-PIN!

13.

1x

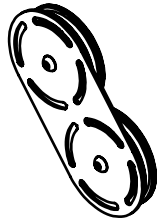

Double Wheel Kit

1x



Single Wheel Kit

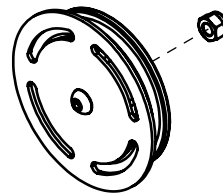
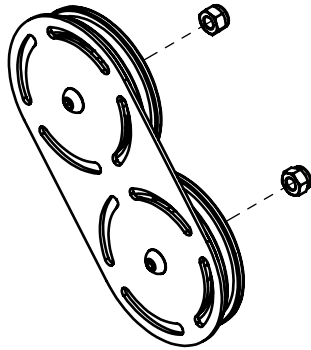

UNSCREW NUTS AND MOUNT BOTH WHEEL KITS!

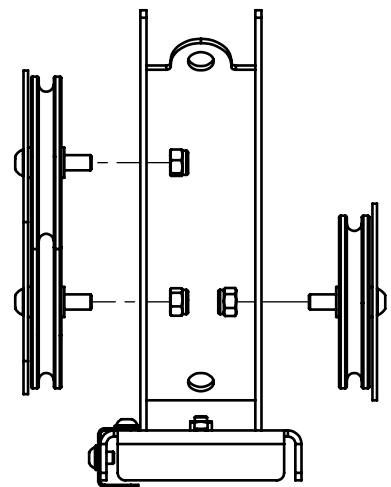
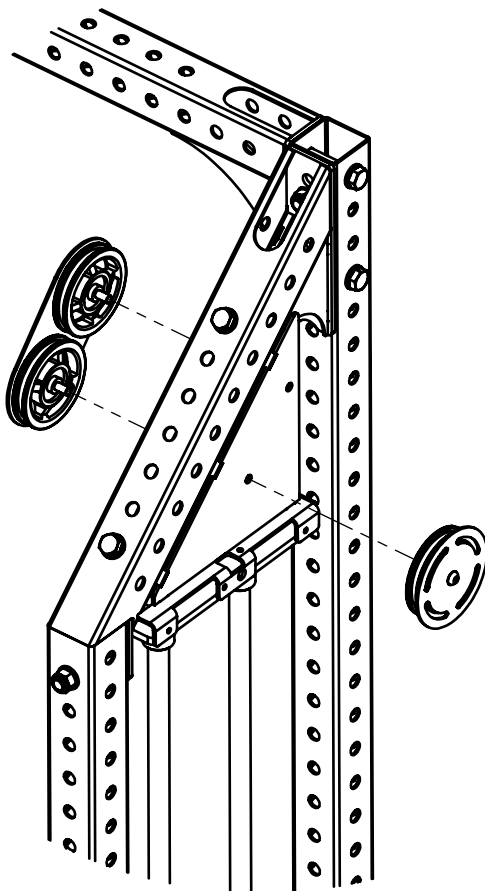

14.

1x



3085601 a9

MOUNT THE TOP WHEEL ONE SCREW AT THE TIME!
START WITH THE TOP ONE!

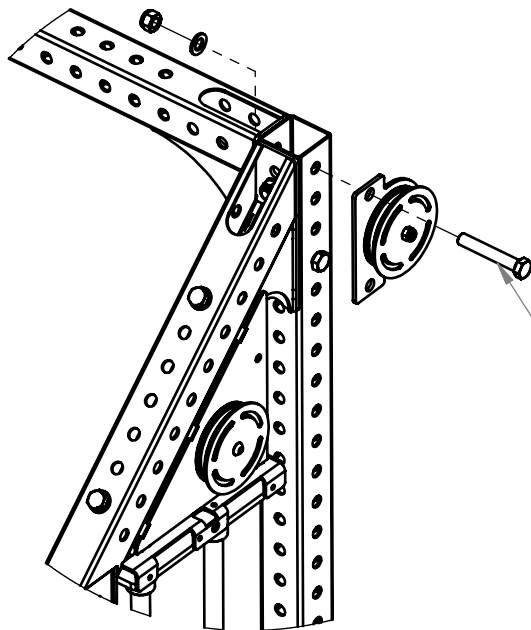

USE EXISTING SCREW WITHOUT
WASHER ON THIS SIDE!

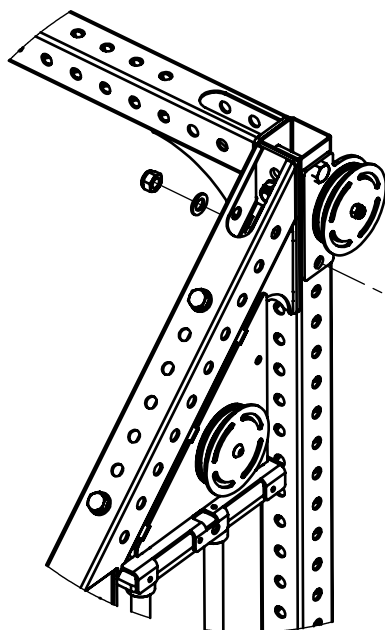

USE EXISTING SCREW WITHOUT
WASHER ON THIS SIDE!

15.

1x

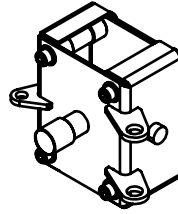

3085601 a3

REMOVE PLATE AND REASSEMBLE ON UPRIGHT!
BE CAREFUL NOT TO LET ANY PARTS FALL OUT!

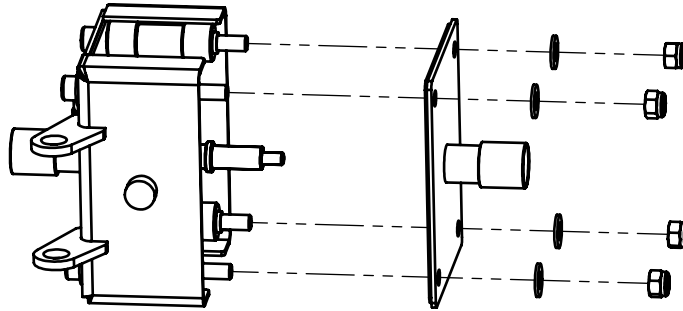

MAKE SURE THE SCREWS ARE NOT TOO TIGHT!
CARRIAGE SHOULD BE EASY TO ADJUST IN HEIGHT!

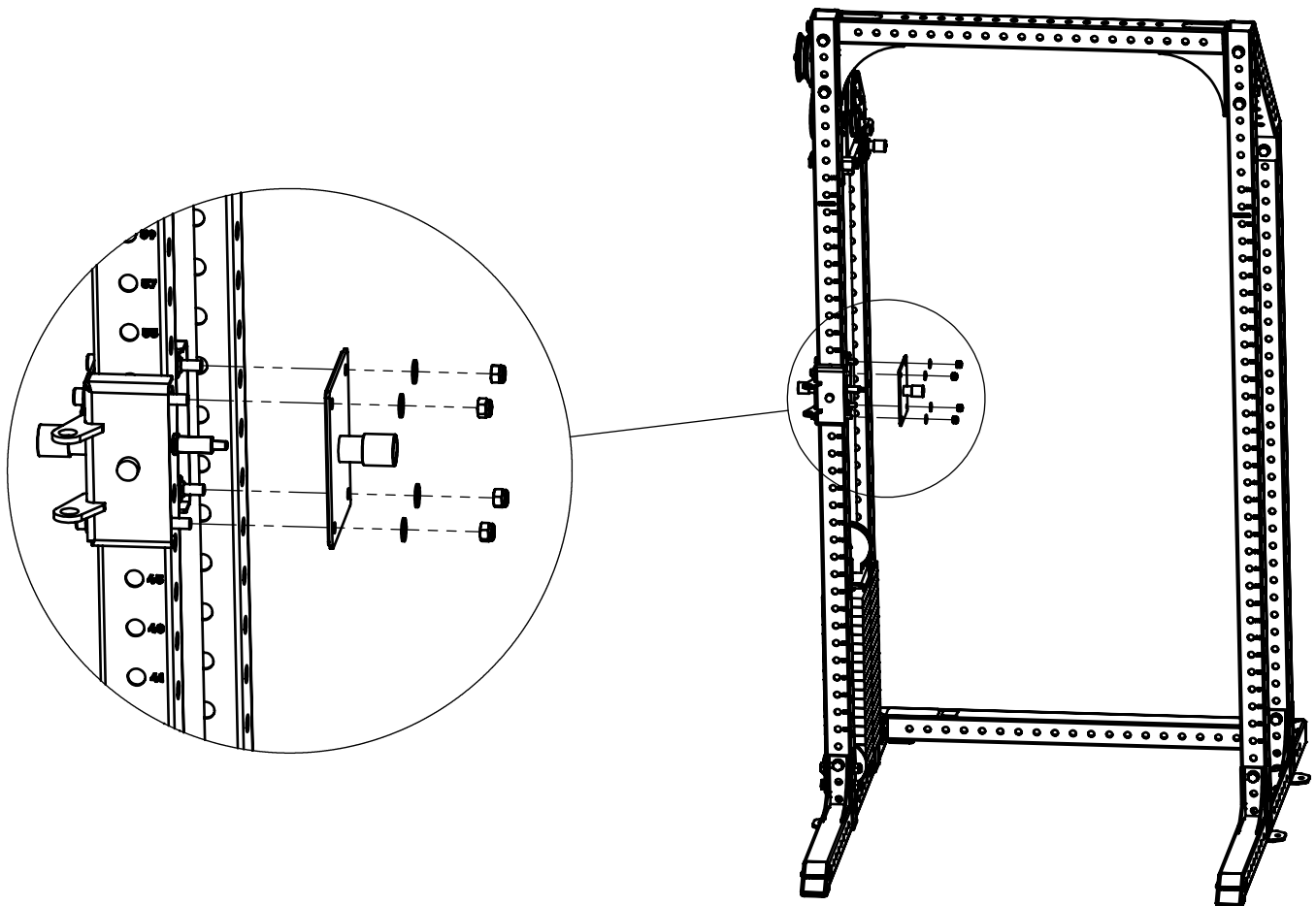

16.

1x



3085601 a6

2x



2001000

1x

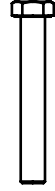

M16 x 110

2x



Washer M16

1x



Locking Nut M16

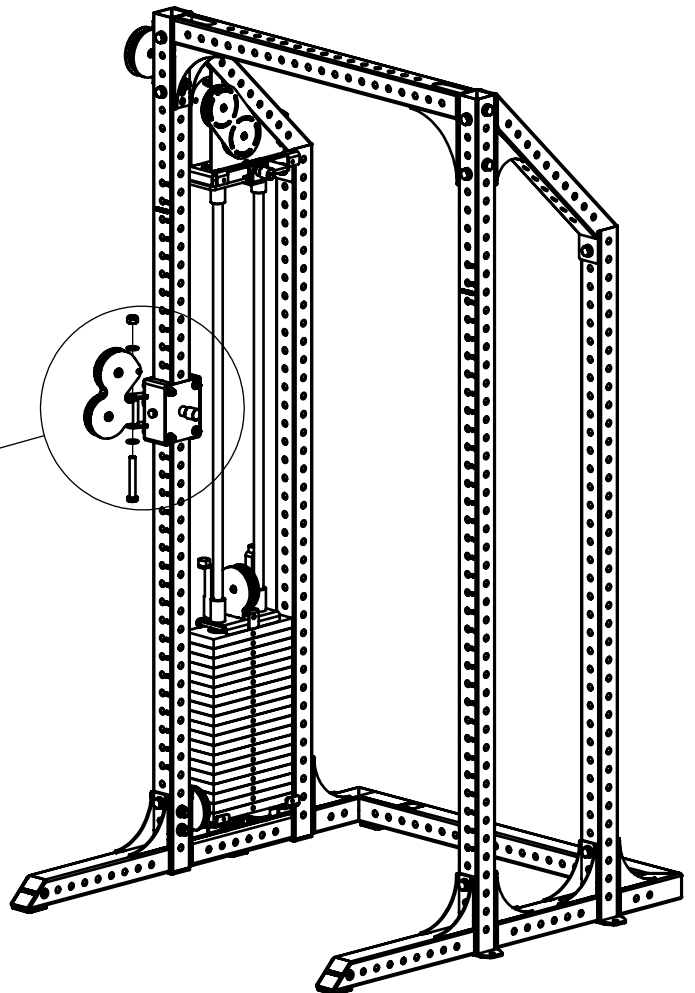
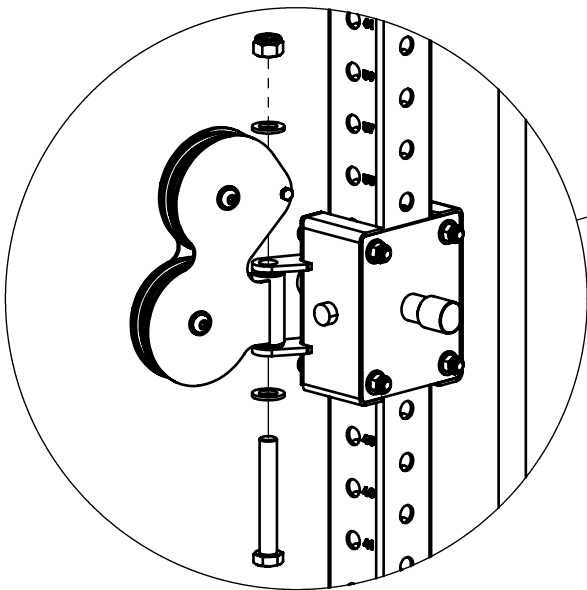
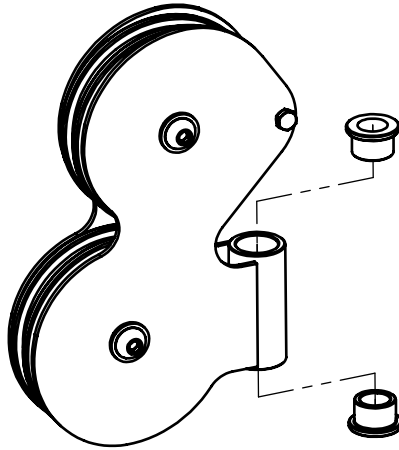

17.

1x



Hollow Screw

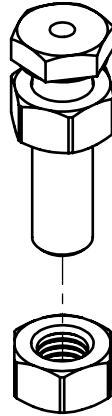

UNSCREW NUT AND MOUNT ON CARRIAGE!

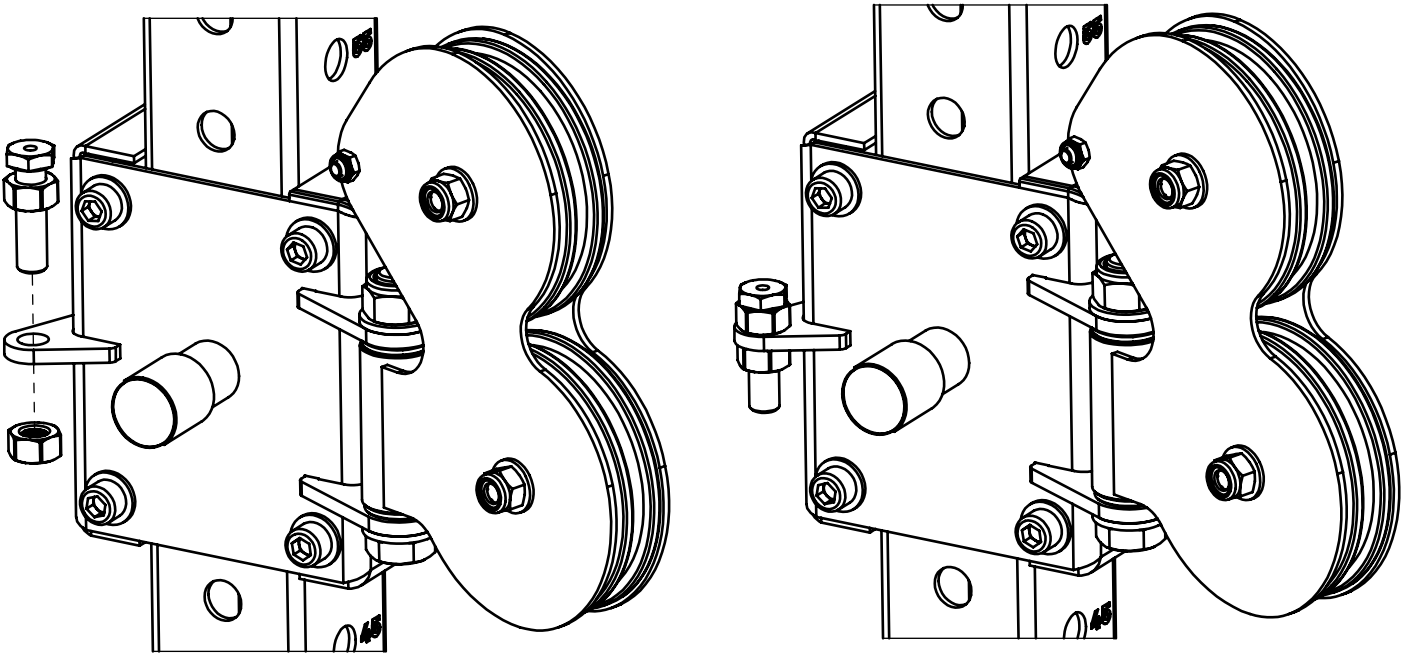

SCREW SHOULD BE AS FAR DOWN AS POSSIBLE!
TENSION IN THE CABLE CAN LATER BE ADJUSTED BY MOVING THE SCREW UPWARDS!

18a.

1x

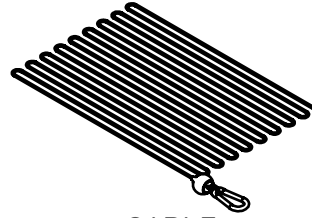

CABLE

Step 1

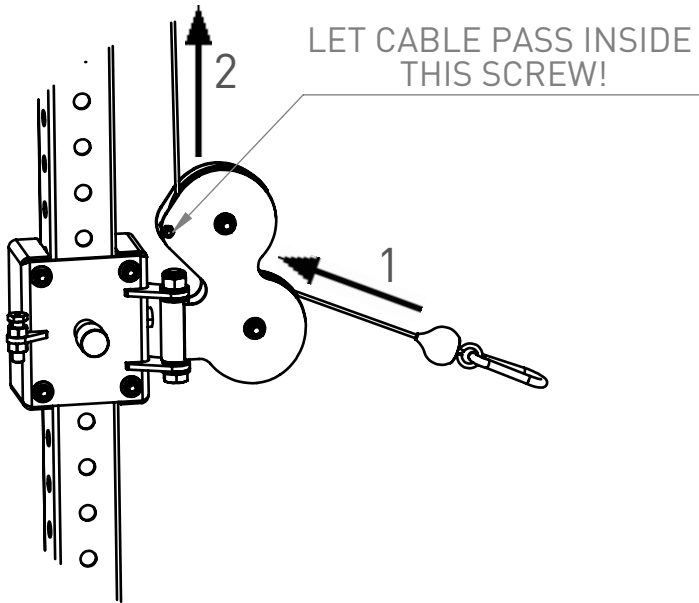

Step 2

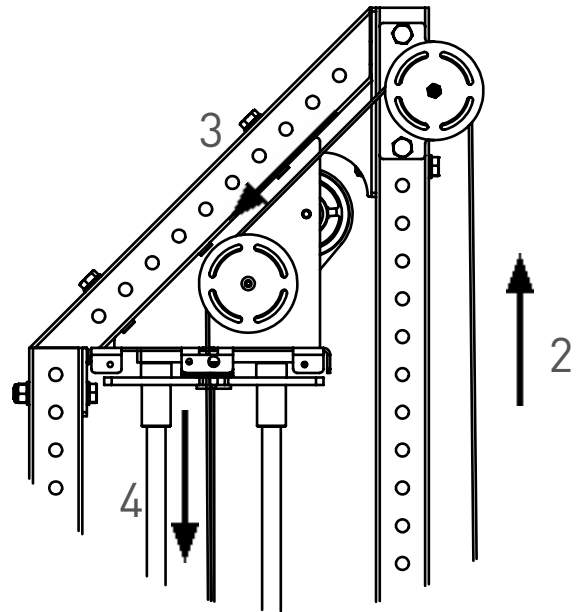

Step 3

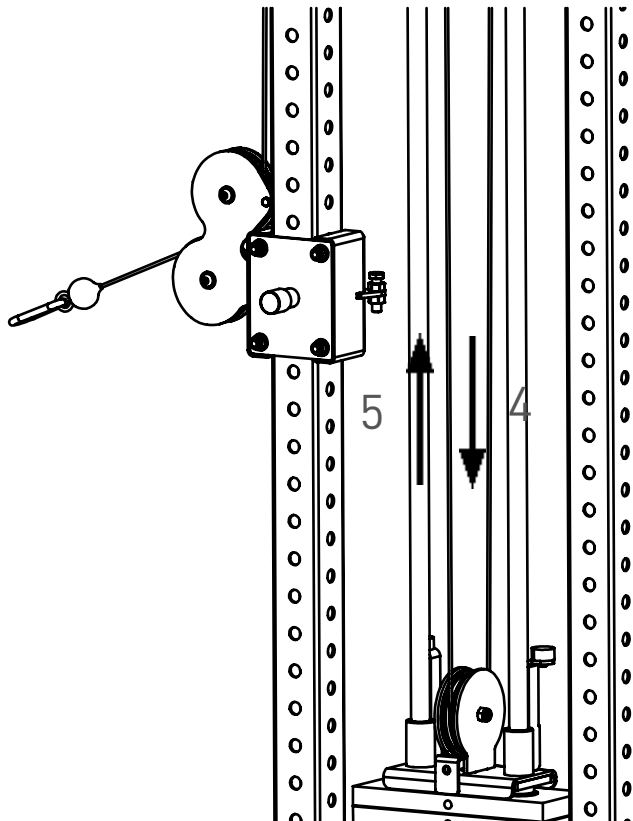

18b.

1x



2001808

Step 4

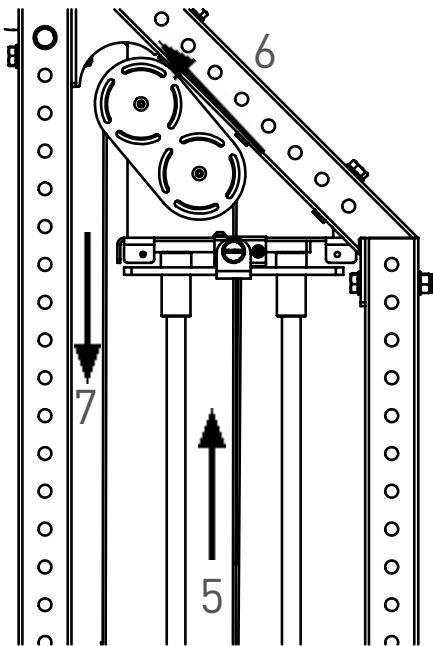

Step 5

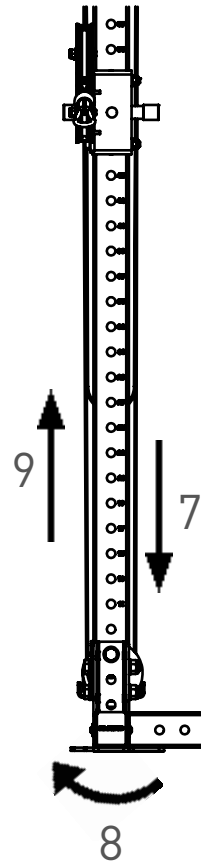

Step 6

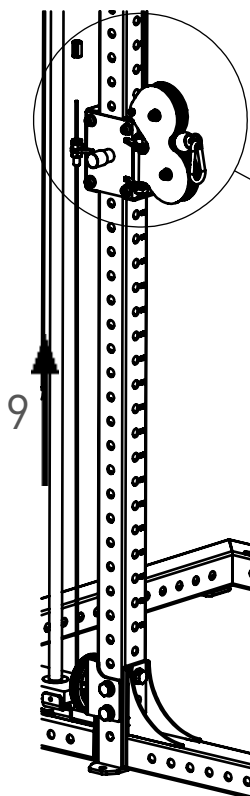

MAKE SURE THE CABLE IS TIGHT BY PULLING ITS END.
LET THE CABLE PASS THROUGH THE HOLLOW SCREW
BEFORE FIXING IT WITH THE CABLE END!
CUT OFF LEFTOVERS FROM CABLE!

2001808

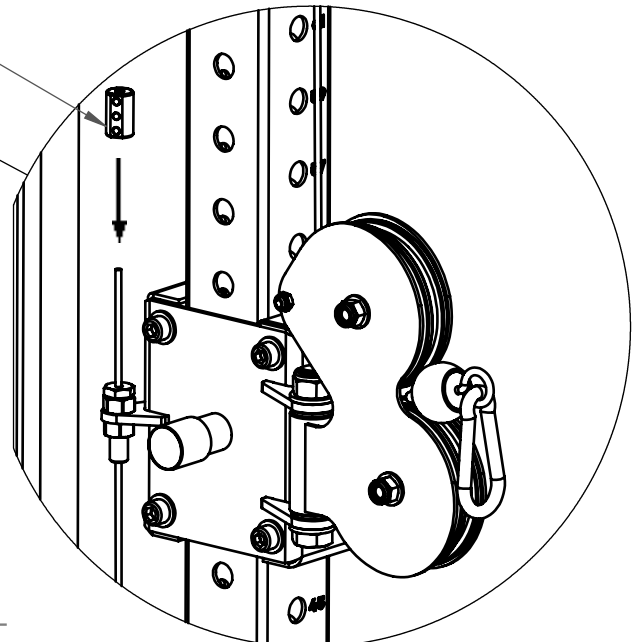

19.

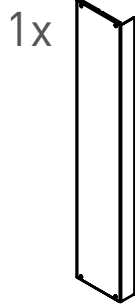

3085601 p25 / 3085709 p2



K6S M8 x 12



Washer M8

WIPE OFF BOTH RODS AGAIN WITH A CLEAN CLOTH
BEFORE MOUNTING COVER PLATE!

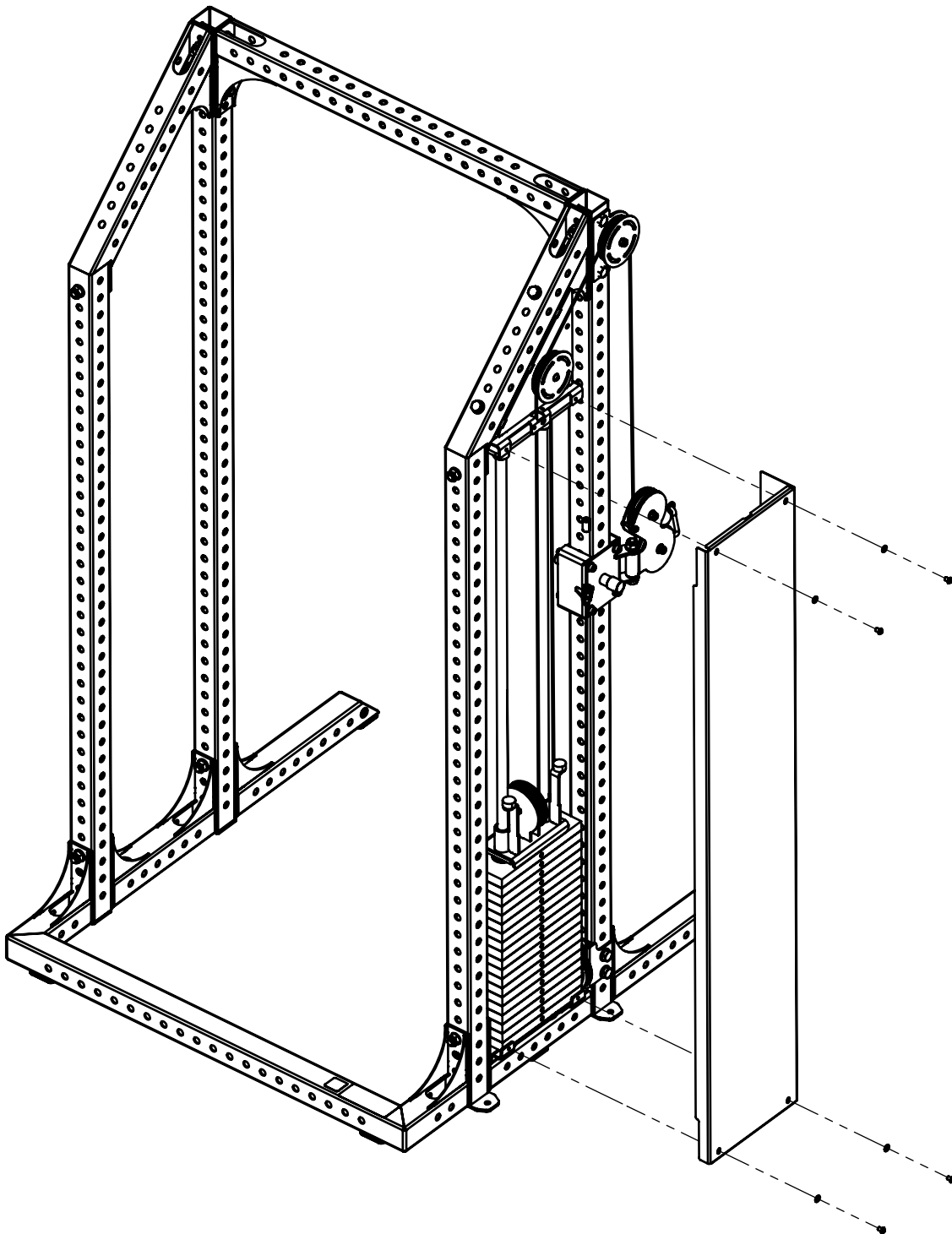

20.

1x

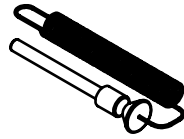

2001483

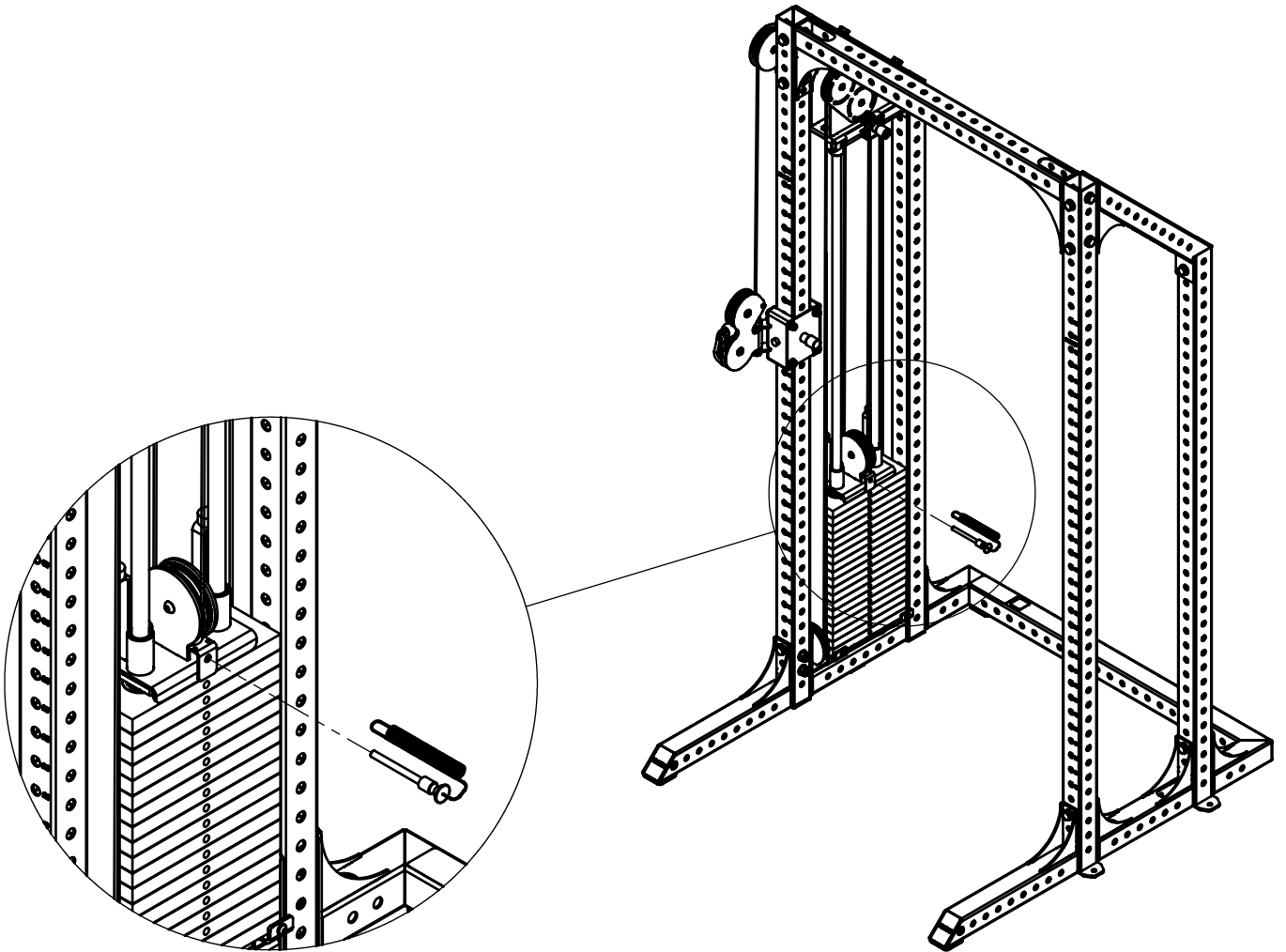

SECURE SELECTOR PIN BY THREADING THE METAL RING INTO THE RIGHT HOLE!

20.

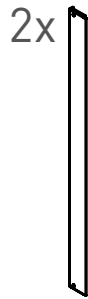

3085601 p11 / 3085709 p1

K6S M8 x 12

Washer M8

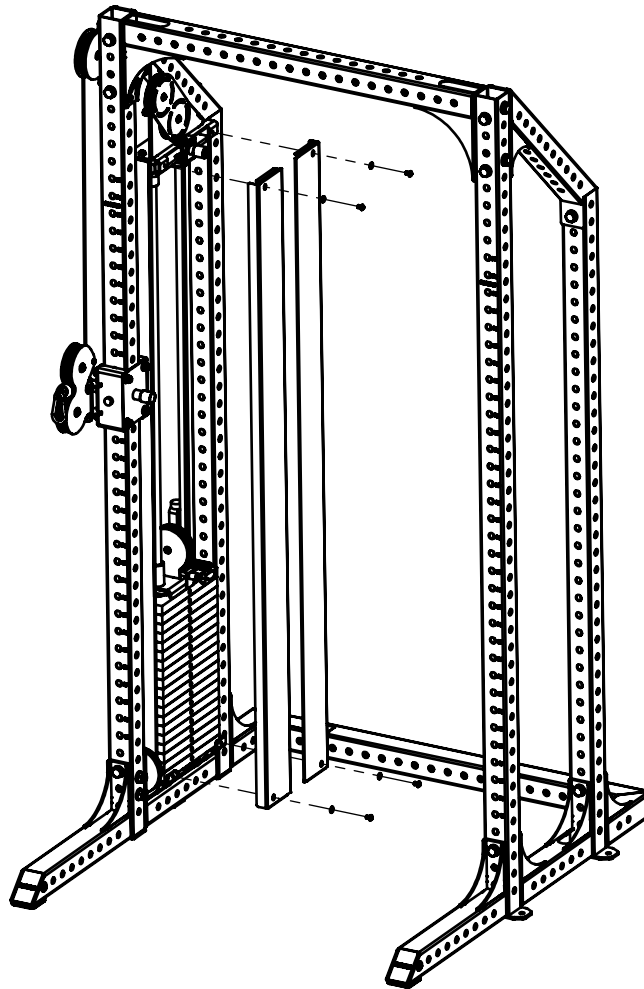

NUMBERS TO THE LEFT OF THE WEIGHT STACK!

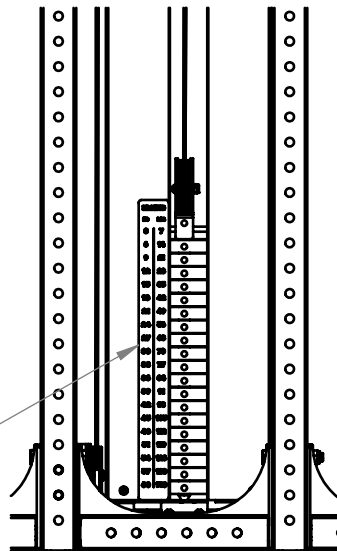

THIS STEP ONLY APPLIES IF YOU HAVE STORAGE PINS!

22.

4x



3061757 p30

or

8x



3061757 p30

FOR ELEIKO PRESTERA STORAGE PINS, FLIP EXISTING RUBBER DAMPERS AND USE THEM TOGETHER WITH FOUR NEW DAMPERS RECEIVED WITH ELEIKO PRESTERA CALBE ATTACHMENT! YOU WILL NOT NEED THE REMAINING FOUR DAMPERS!

4x

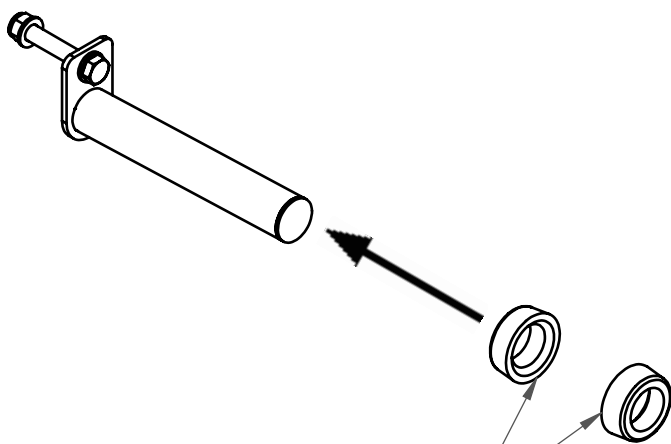

LARGE ENDS AGAINST EACH OTHER!

FOR ELEIKO PRESTERA CHROMED STORAGE PINS, USE ALL EIGHT DAMPERS RECEIVED WITH ELEIKO PRESTERA CALBE ATTACHMENT!

4x

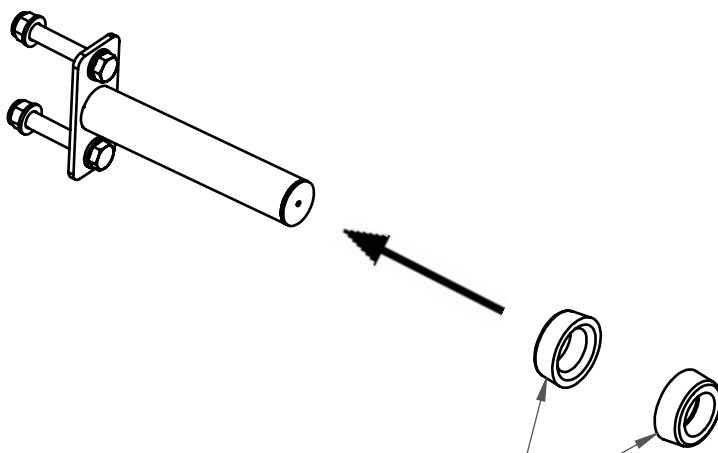

LARGE ENDS AGAINST EACH OTHER!

ASSEMBLY INSTRUCTIONS RIGHT SIDE

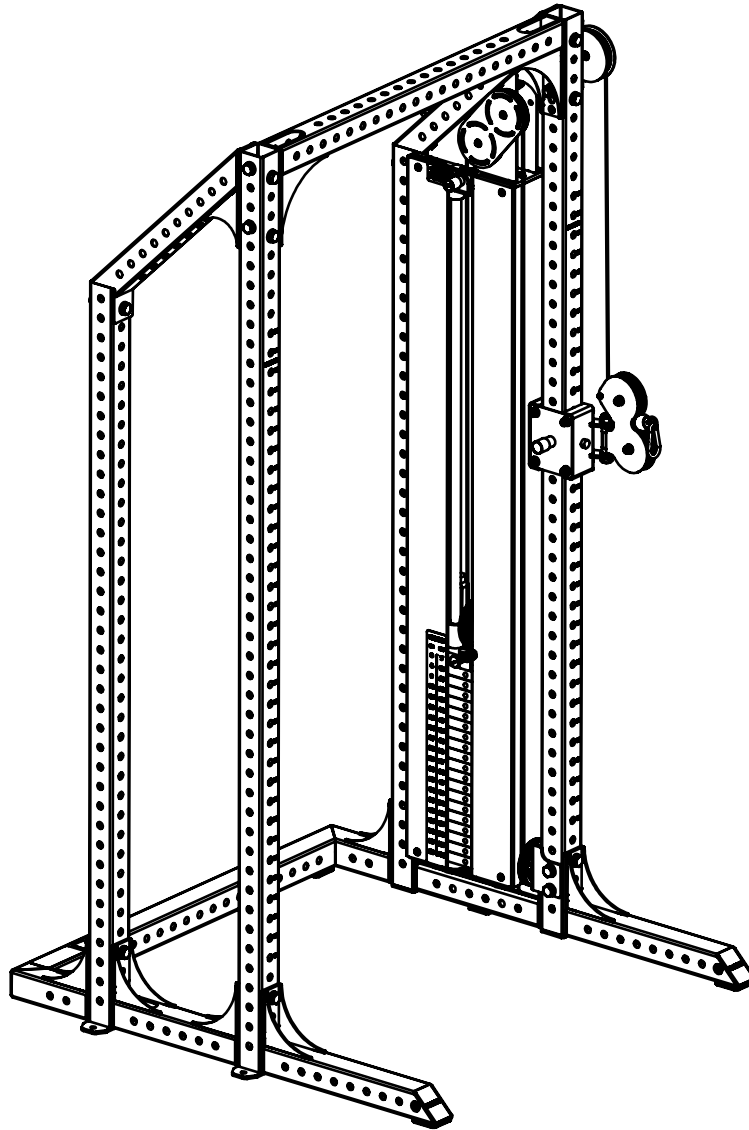

ASSEMBLY INSTRUCTIONS FOR THE LEFT SIDE CAN BE FOUND ON
PAGE 6





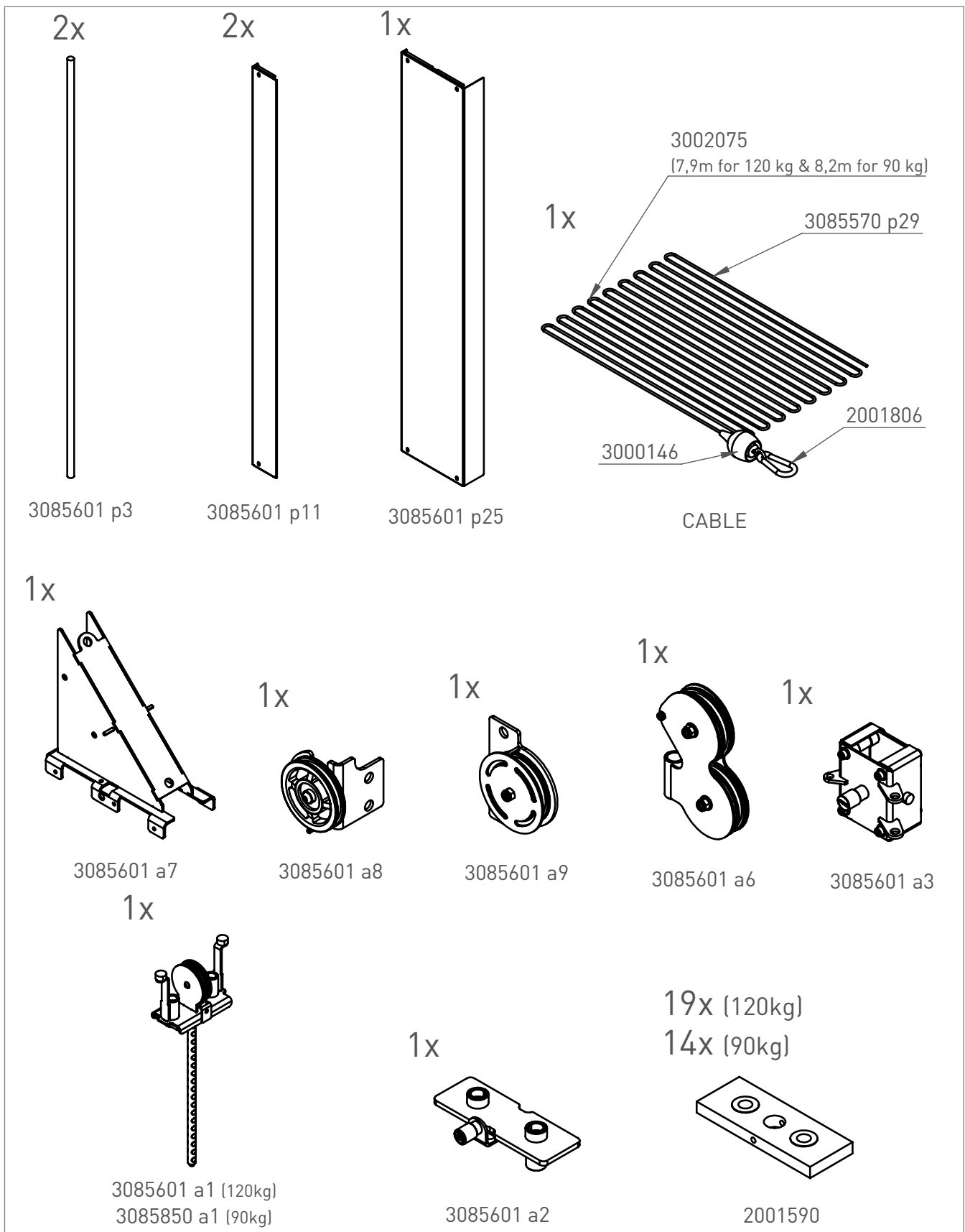





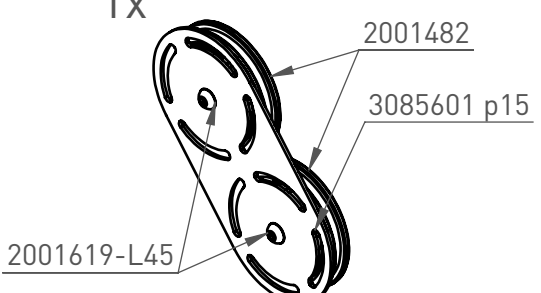
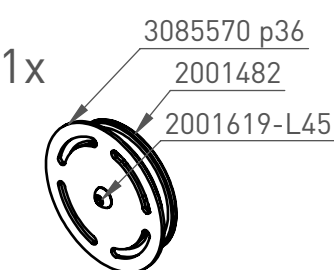
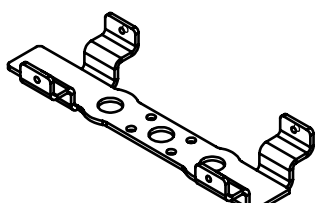
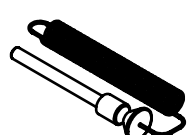
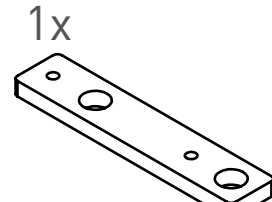

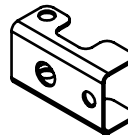

LIST OF COMPONENTS

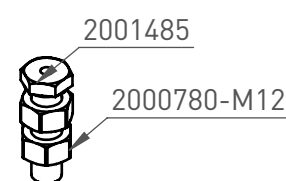
Eleiko Prestera Cable Attachment
 Art.no 3085601 (120kg) & 3085850 (90kg)

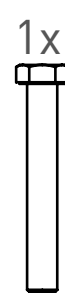

LIST OF COMPONENTS

Eleiko Pretera Cable Attachment
 Art.no 3085601 (120kg) & 3085850 (90kg)

<p>1x</p>  <p>2001482 3085601 p15 2001619-L45</p> <p>Double Wheel Kit</p>	<p>1x</p>  <p>3085570 p36 2001482 2001619-L45</p> <p>Single Wheel Kit</p>	<p>1x</p>  <p>3085601 p8</p>		
<p>1x</p>  <p>2001483</p>	<p>1x</p>  <p>3085601 p9</p>	<p>2x</p>  <p>3085570 p33</p>	<p>2x</p>  <p>3085570 p34</p>	
<p>1x</p>  <p>2001808</p>	<p>2x</p>  <p>2001000</p>	<p>1x</p>  <p>3085601 p6</p>	<p>8x</p>  <p>3061757 p30 USED FOR STORAGE PINS</p>	
<p>1x</p>  <p>2001485 2000780-M12</p> <p>Hollow Screw</p>	<p>2x</p>  <p>K6S M8 x 30 2000747-L30</p>	<p>14x</p>  <p>K6S M8 x 12 2001620-L12</p>	<p>16x</p>  <p>Washer M8 2001422</p>	
<p>1x</p>  <p>M16 x 110 2001385-L110</p>	<p>5x</p>  <p>M16 x 100 2001385-L100</p>	<p>10x</p>  <p>Washer M16 2001421</p>	<p>5x</p>  <p>Locking Nut M16 2001379</p>	<p>1x</p>  <p>Nut M16 2000780</p>





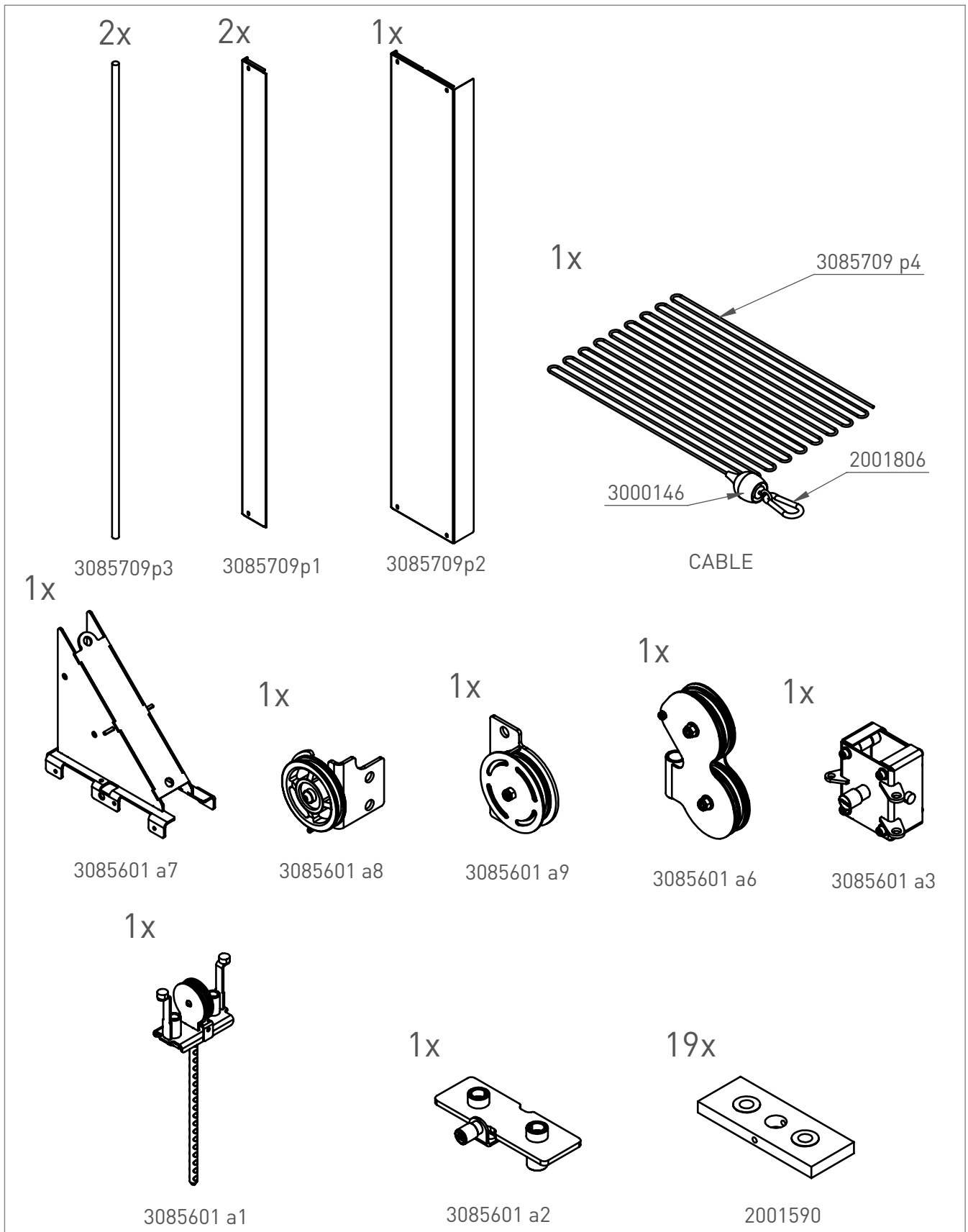





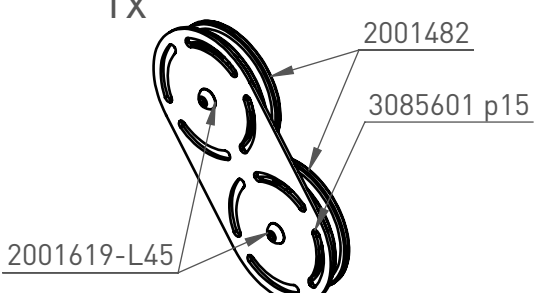
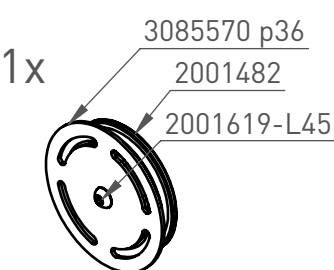
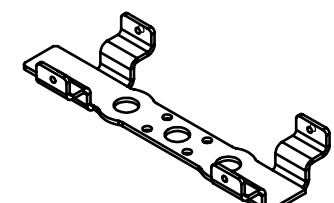
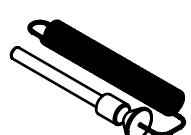
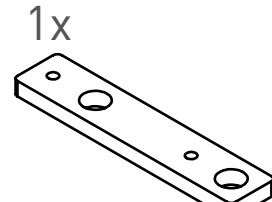

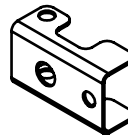

LIST OF COMPONENTS

Eleiko Pretera Cable Attachment - Tall Rack
Art.no 3085709

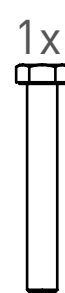

LIST OF COMPONENTS

Eleiko Pretera Cable Attachment - Tall Rack
Art.no 3085709

<p>1x</p>  <p>2001482 3085601 p15 2001619-L45</p> <p>Double Wheel Kit</p>	<p>1x</p>  <p>3085570 p36 2001482 2001619-L45</p> <p>Single Wheel Kit</p>	<p>1x</p>  <p>3085601 p8</p>		
<p>1x</p>  <p>2001483</p>	<p>1x</p>  <p>3085601 p9</p>	<p>2x</p>  <p>3085570 p33</p>	<p>2x</p>  <p>3085570 p34</p>	
<p>1x</p>  <p>2001808</p>	<p>2x</p>  <p>2001000</p>	<p>1x</p>  <p>3085601 p6</p>	<p>8x</p>  <p>3061757 p30 USED FOR STORAGE PINS</p>	
<p>1x</p>  <p>2001485 2000780-M12</p> <p>Hollow Screw</p>	<p>2x</p>  <p>K6S M8 x 30 2000747-L30</p>	<p>14x</p>  <p>K6S M8 x 12 2001620-L12</p>	<p>16x</p>  <p>Washer M8 2001422</p>	
<p>1x</p>  <p>M16 x 110 2001385-L110</p>	<p>5x</p>  <p>M16 x 100 2001385-L100</p>	<p>10x</p>  <p>Washer M16 2001421</p>	<p>5x</p>  <p>Locking Nut M16 2001379</p>	<p>1x</p>  <p>Nut M16 2000780</p>

PREPARATION

IF YOU HAVE ALSO PURCHASED A SVR
INSERT PLATFORM, INSTALL THE
PLATFORM FIRST!

BEFORE YOU START THIS ASSEMBLY,
REMOVE EVENTUAL GLIDING J-CUPS
AND/OR GLIDING SAFETY ARMS!

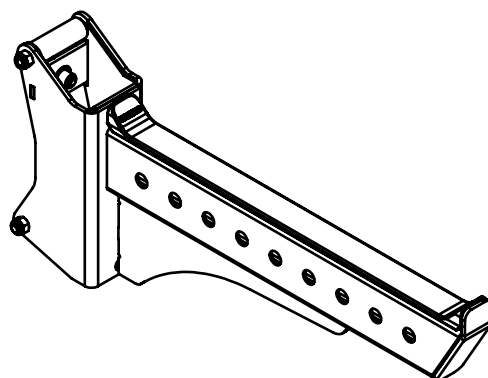
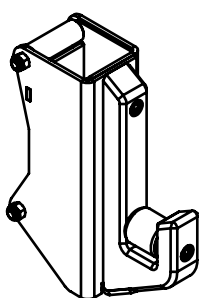

ALSO REMOVE THE RUBBER DAMPERS IF
YOU HAVE ELEIKO PRESTERA STORAGE
PINS, SAVE THESE FOR LATER!

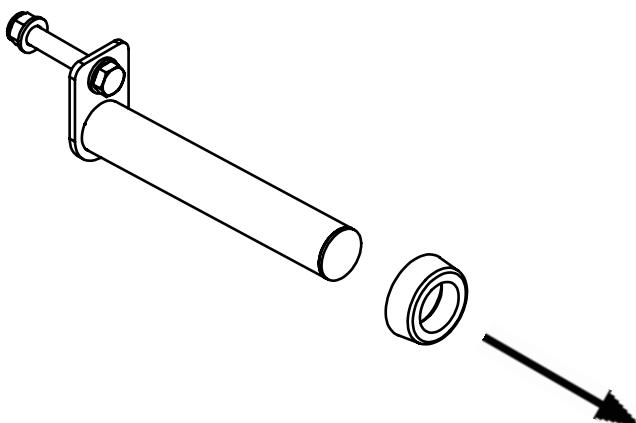

1.

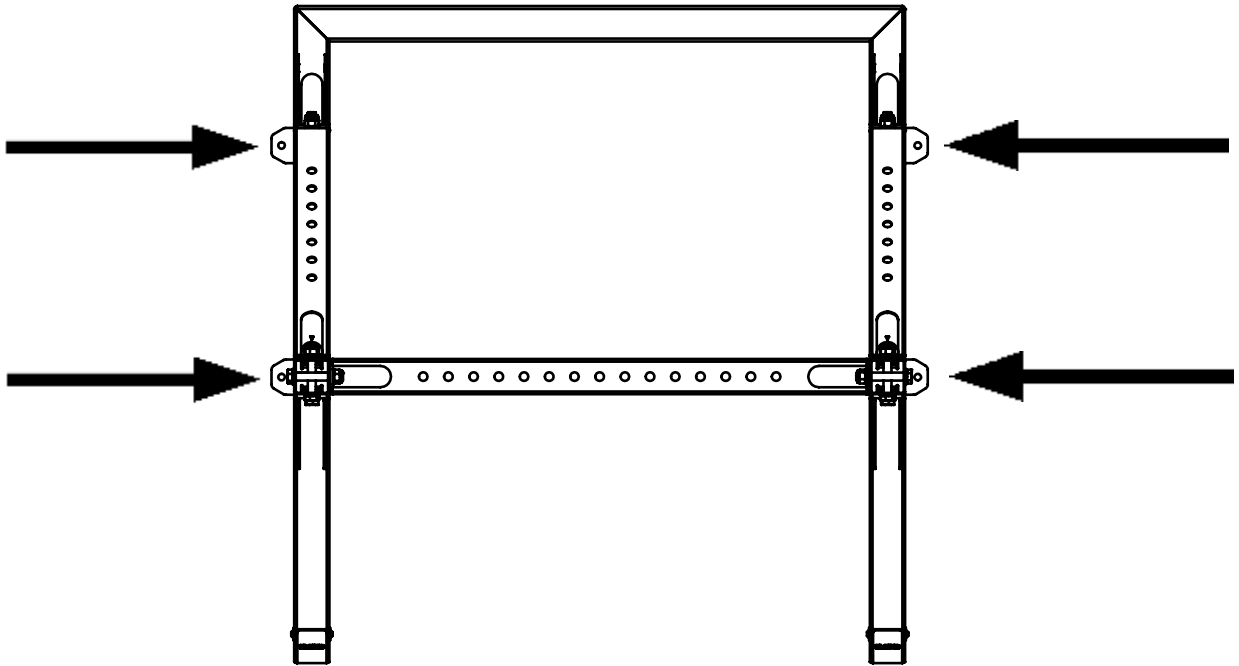

When using Eleiko Prestera Cable Attachment for Eleiko Prestera Tall Rack, the rack **MUST** be bolted to the ground!

2.

REMOVE TOP COVER PLATE!

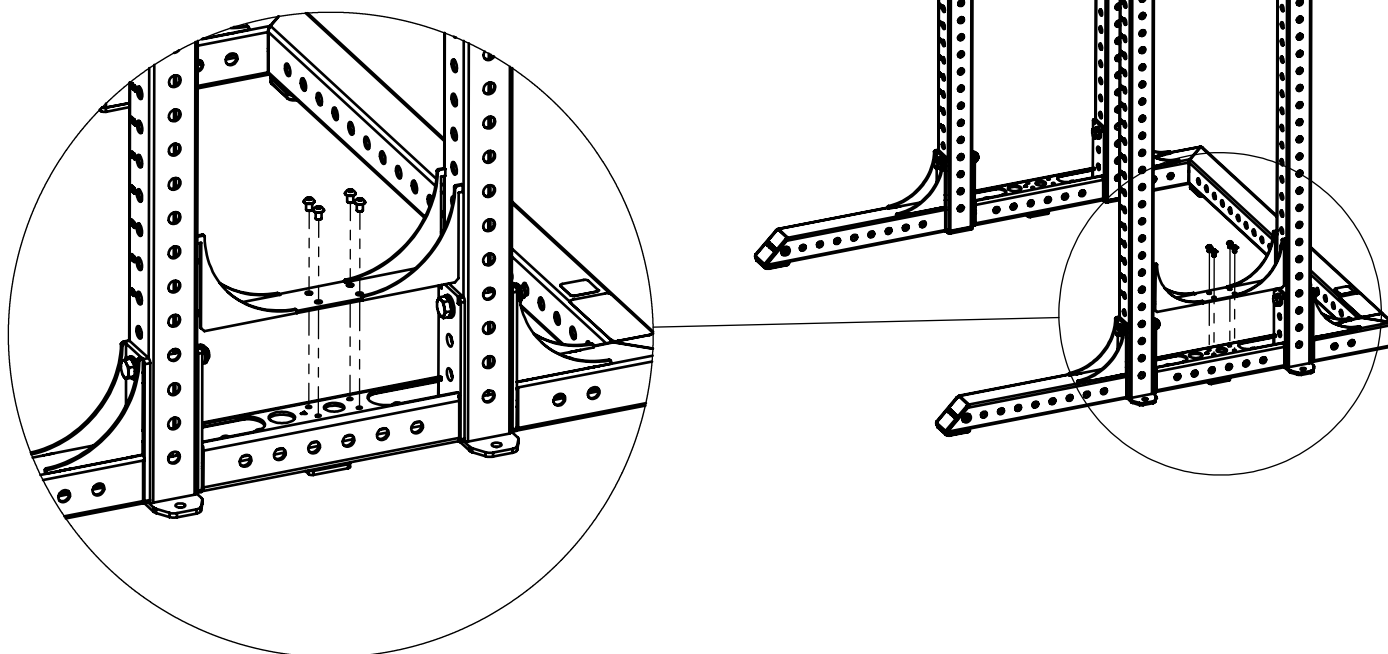

YOU WILL NOT NEED SCREWS AND COVER PLATE ANYMORE.
SAVE THE PARTS IN CASE YOU REMOVE THE CABLE ATTACHMENT IN THE FUTURE!

ONLY FOR DOUBLE HALF RACK
WITH TWO CABLE ATTACHMENTS, FRONT AND BACK

3.

1x



M16 x 100

1x



Nut M16

IF YOU HAVE A DOUBLE HALF RACK AND PLAN TO HAVE TWO CABLE ATTACHMENTS, FRONT AND BACK, CHANGE THIS SCREW TO A M16x100.
ALSO REMOVE BOTH WASHERS AND REPLACE THE LOCKING NUT!

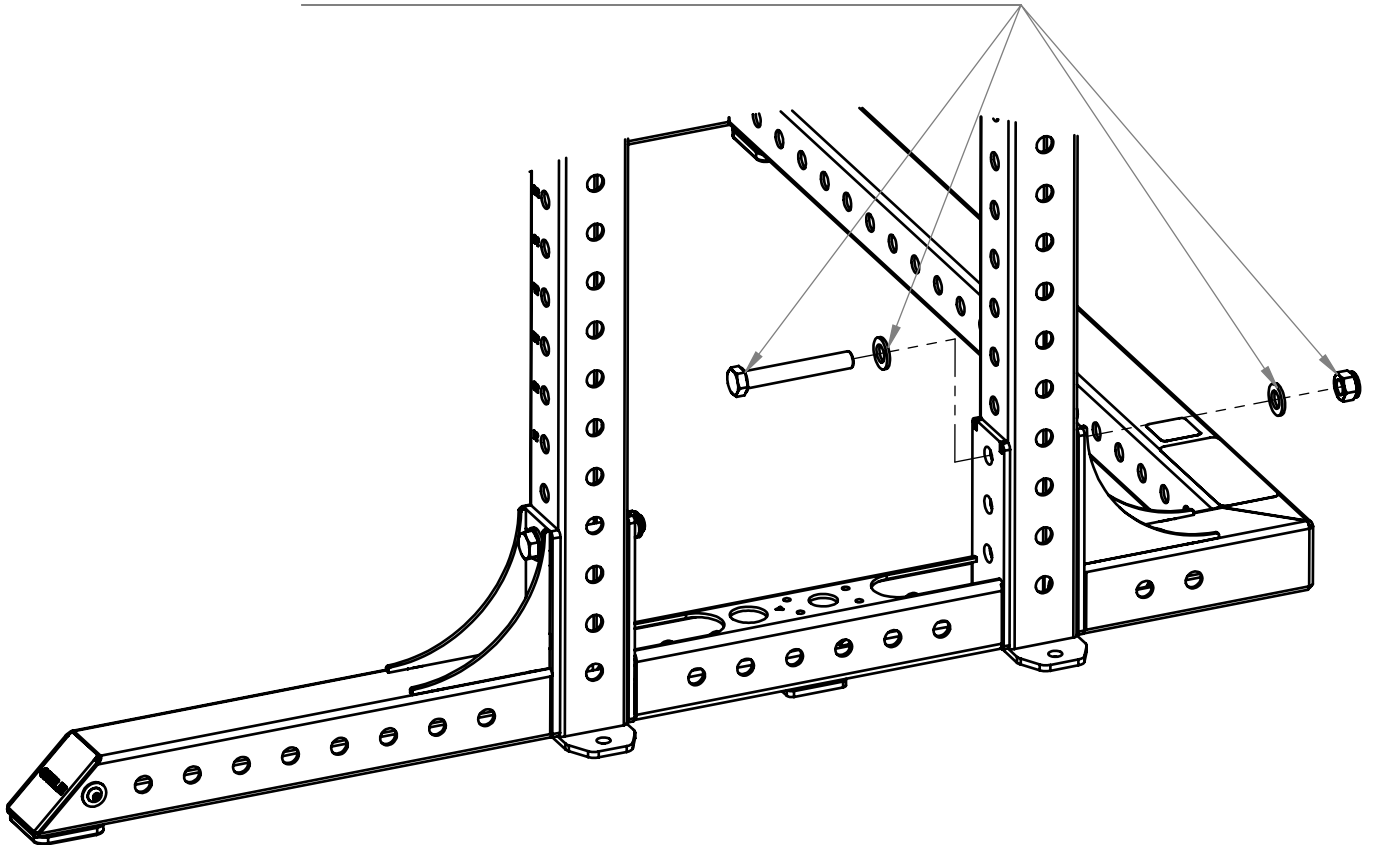

4.

1x

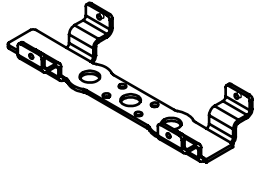

3085601 p8

4x



K6S M8 x 12

4x



Washer M8

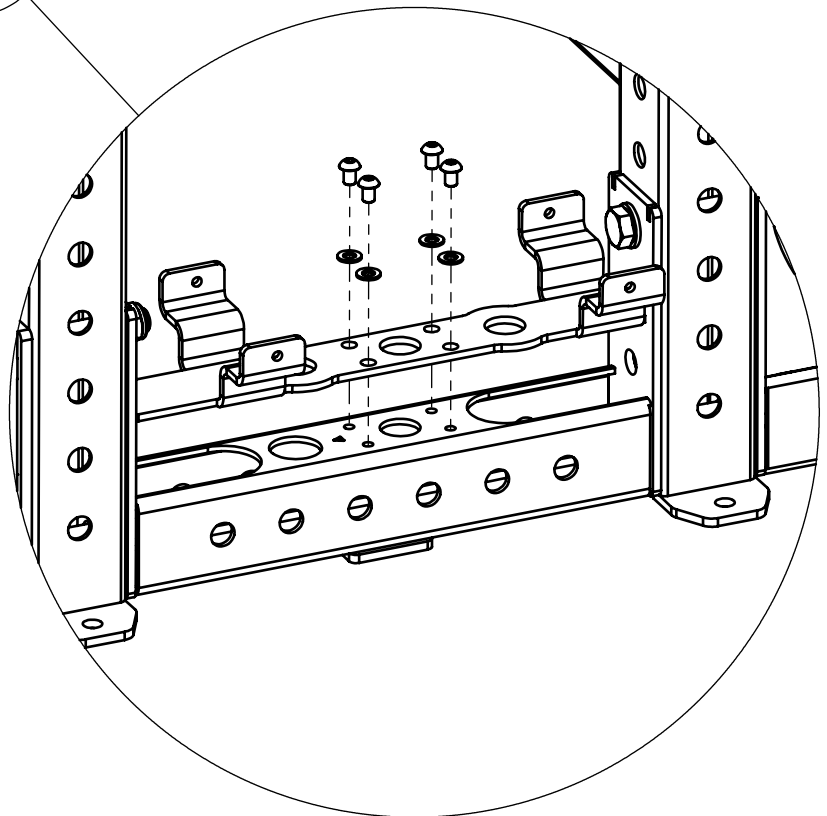
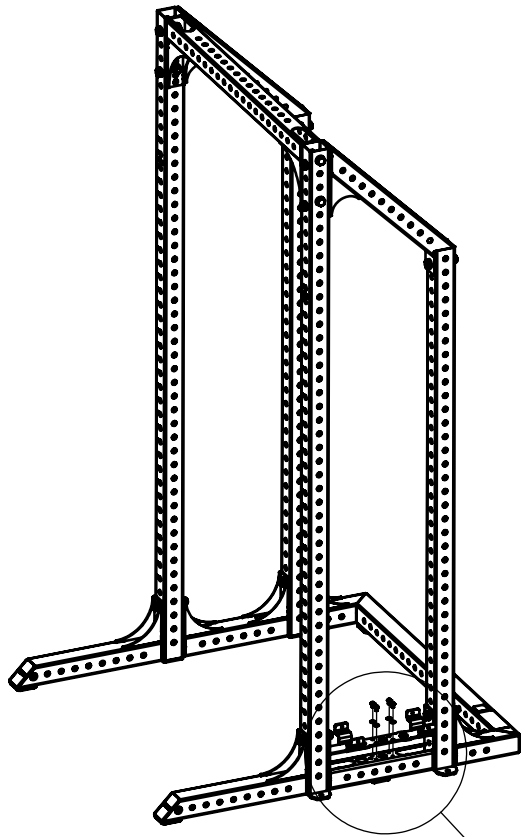

5.

1x

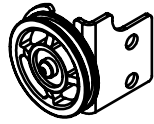

3085601 a8

2x

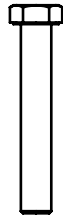

M16 x 100

4x



Washer M16

2x



Locking Nut M16

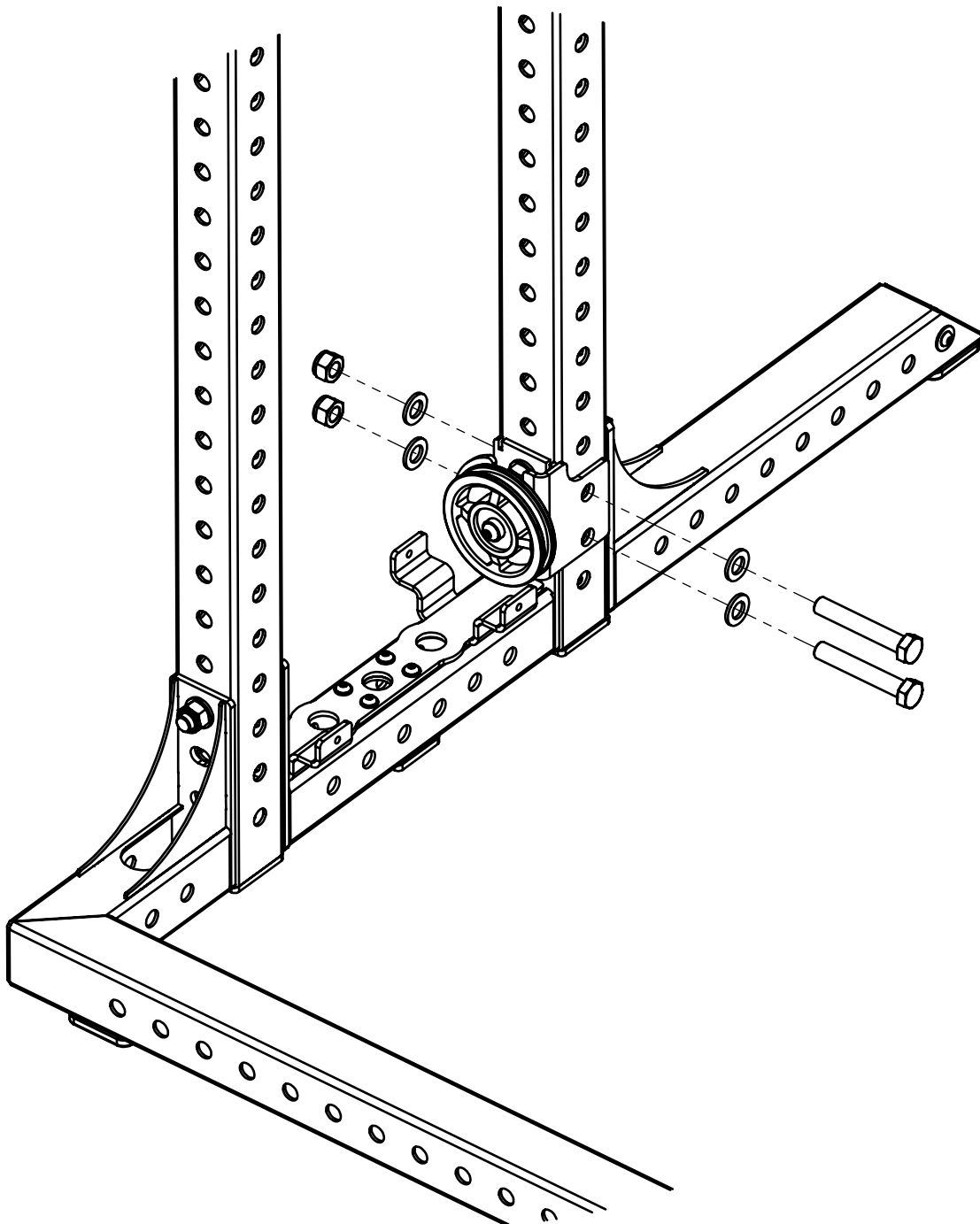

6.

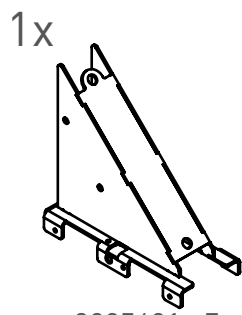

3085601 a7

2x

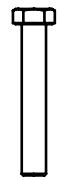

M16 x 100

4x



Washer M16

2x



Locking Nut M16

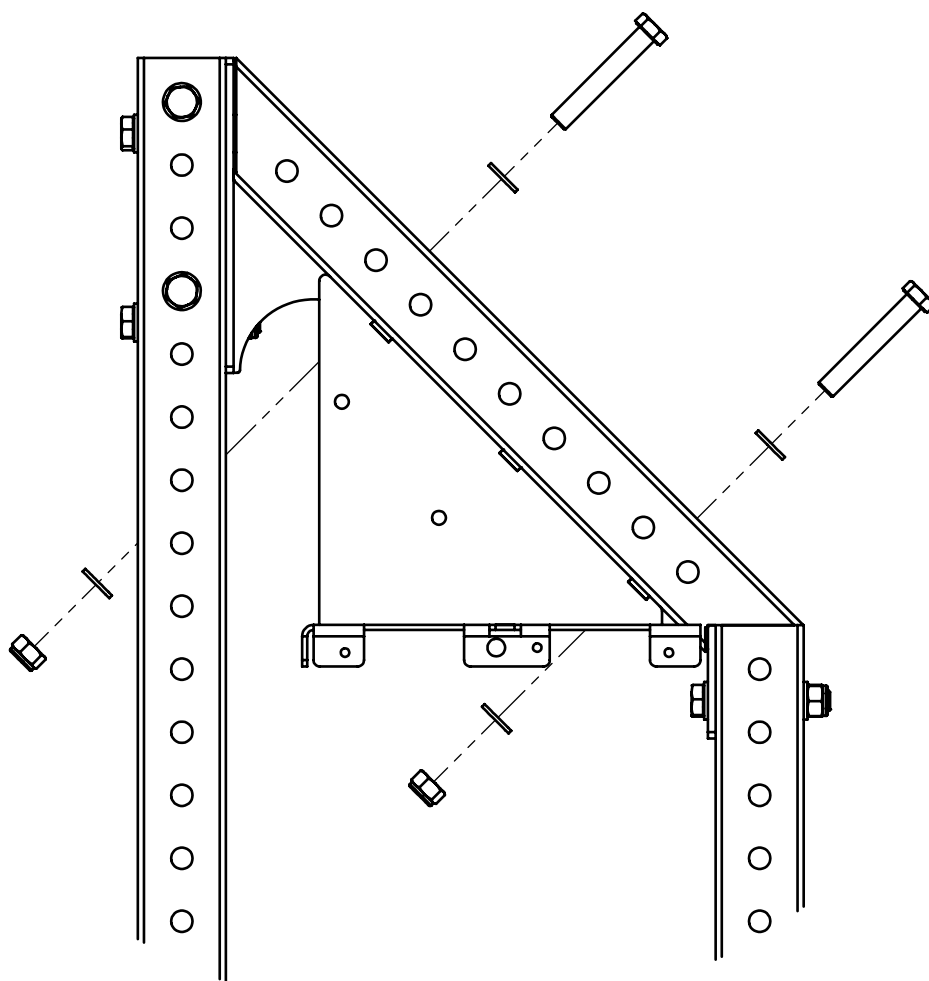

7.



3085601 p3 / 3085709 p3

2x



3085570 p33

2x



3085570 p34

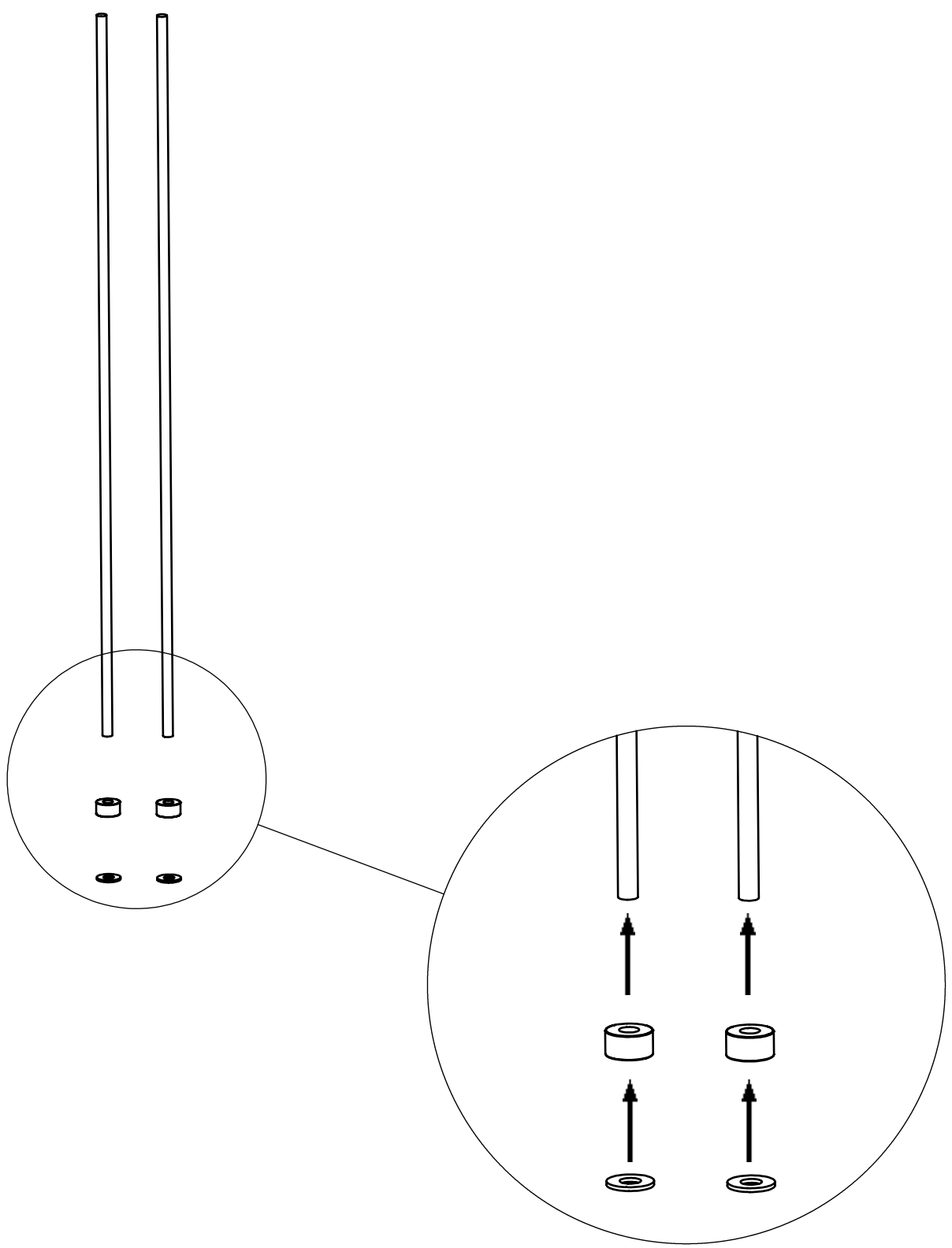

8.

PLACE RODS IN TILTED POSITION IN THESE HOLES.
RUBBER DAMPERS AND DISTANCE PLATES DOWN!

WIPE OFF BOTH RODS WITH A CLEAN CLOTH!

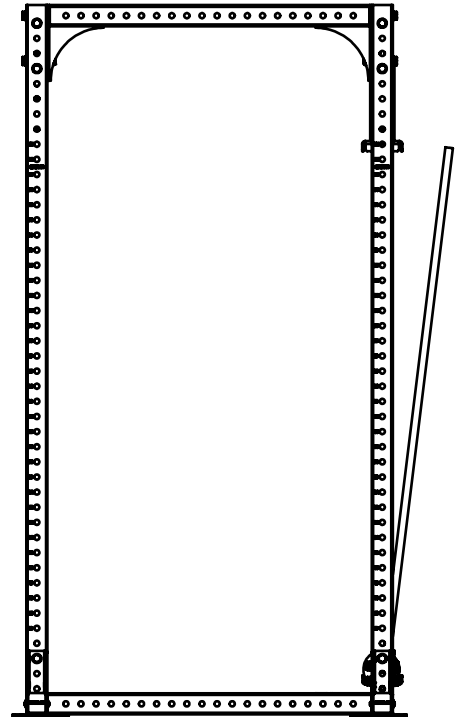
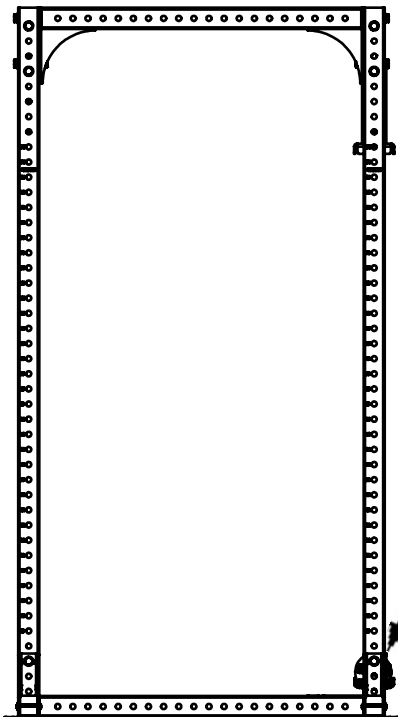
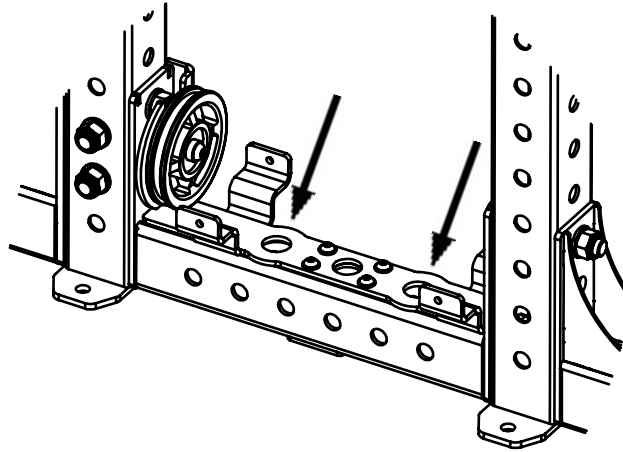

9.

19x / 14x

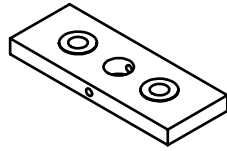

2001590

ASSEMBLE THE WEIGHT STACK PLATE BY PLATE!

MAKE SURE THE FIRST PLATE IS PUSHED ALL THE WAY DOWN AND LOCKED IN POSITION!

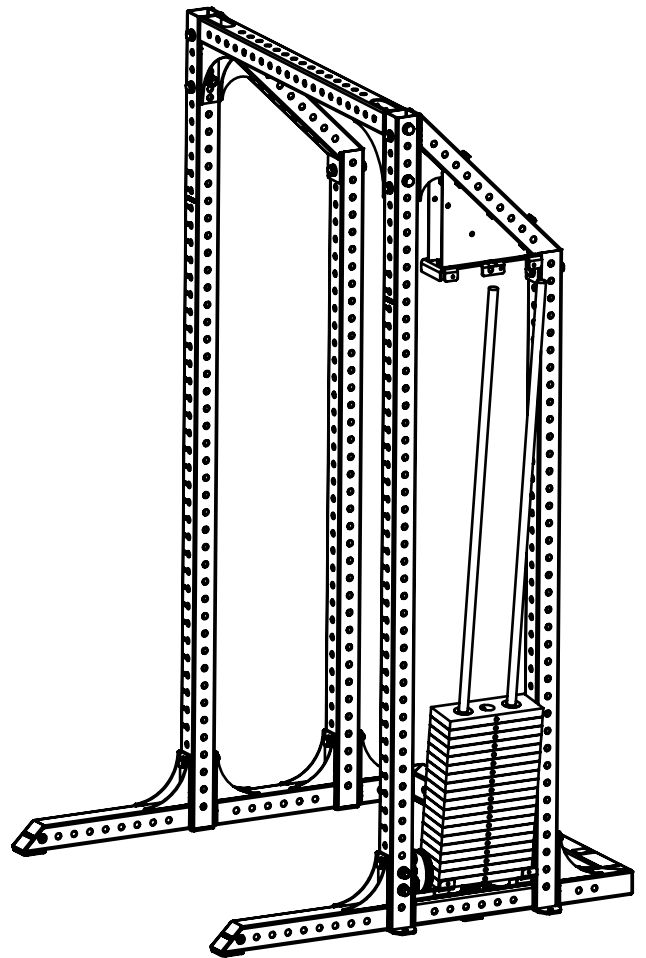
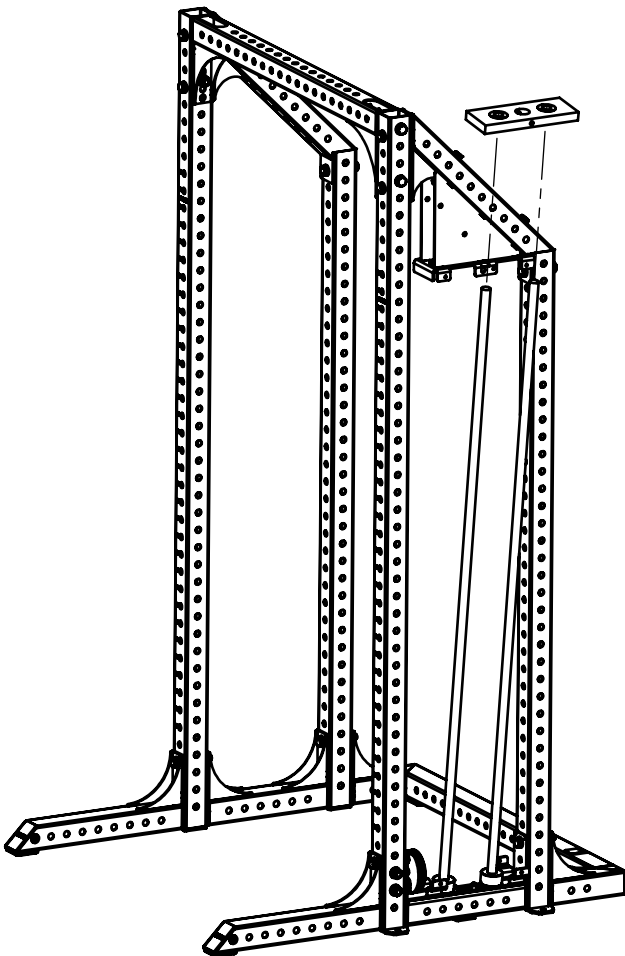

10.

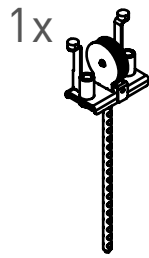

3085601 a1 / 3085850 a1

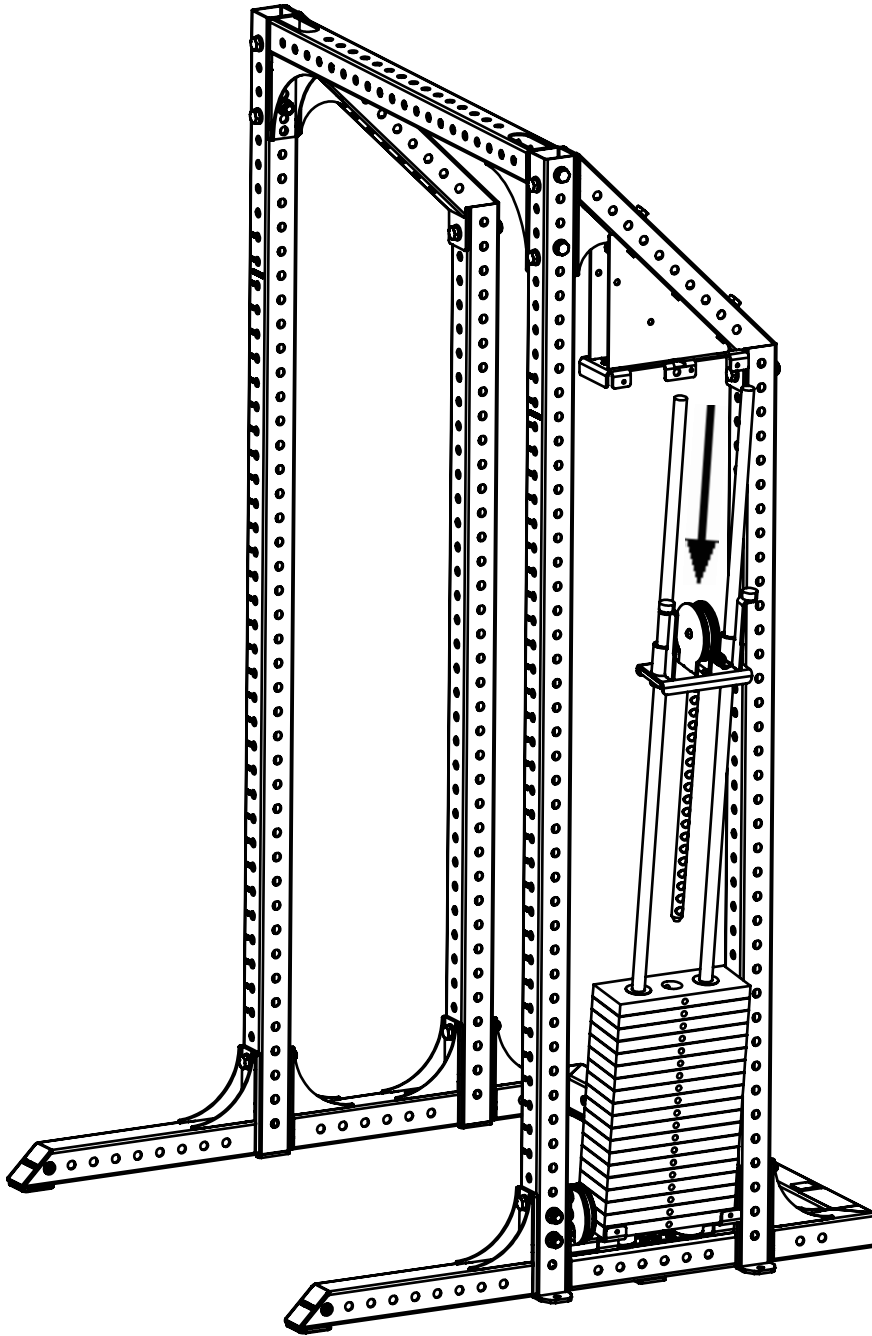

11.

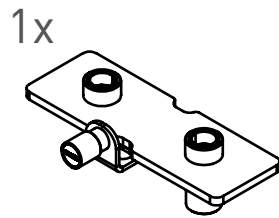

3085601 a2

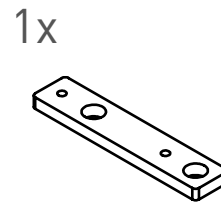

3085601 p9

MOUNT TOP WEIGHT AND PLASTIC TOP SUSPENSION!
PUSH TO VERTICAL POSITION!

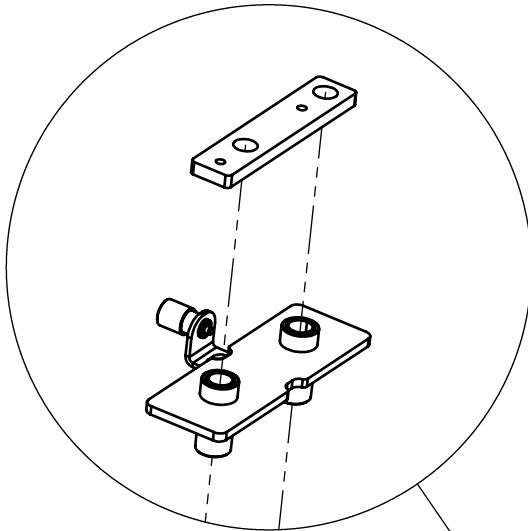

TOP WEIGHT AND PLASTIC TOP SUSPENSION
MUST BE TURNED THIS WAY!

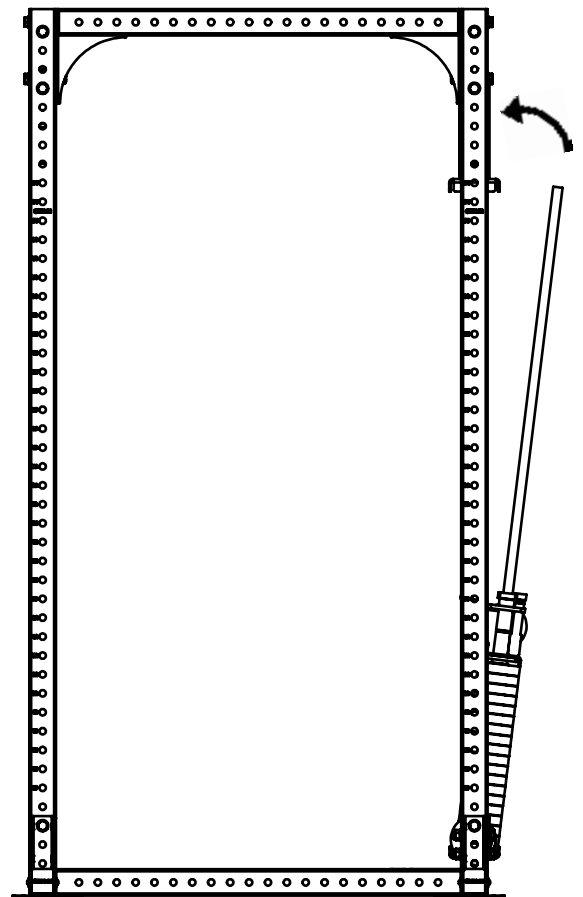
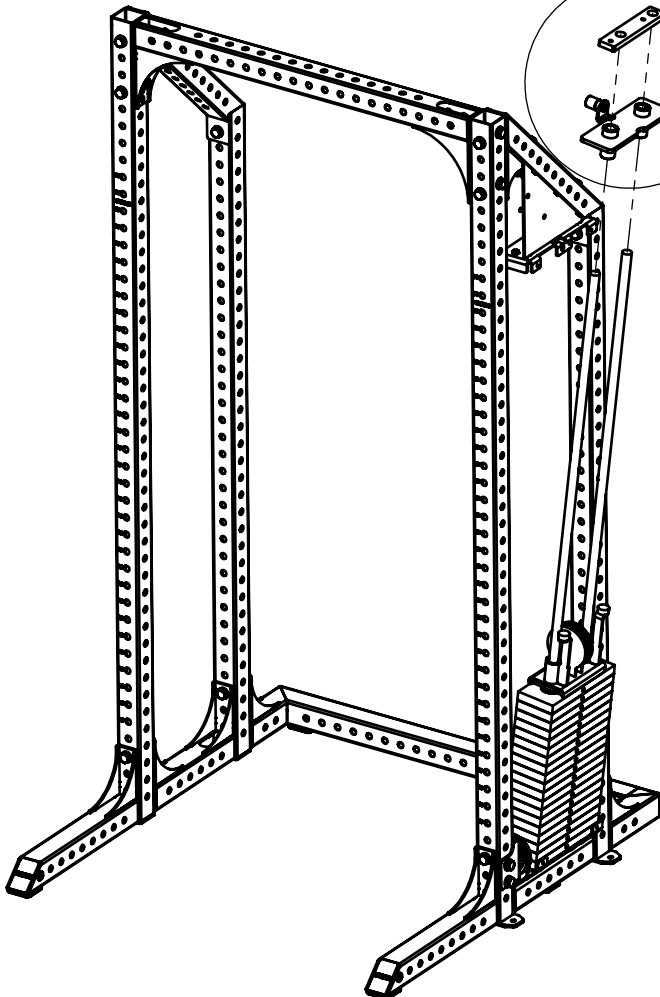
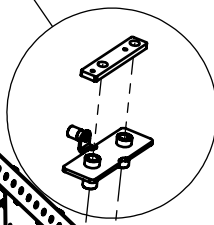

12.

1x

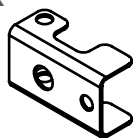

3085601 p6

2x



K65 M8 x 30

2x



K65 M8 x 12

4x



Washer M8

PLASTIC TOP SUSPENSION
FROM PREVIOUS STEP!

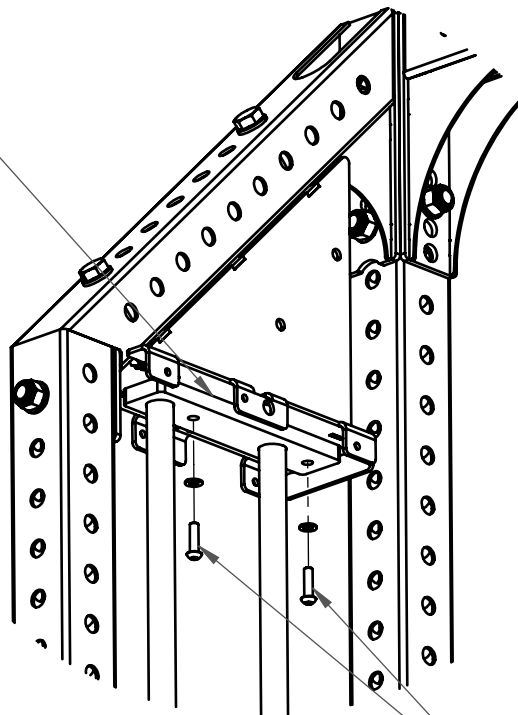

M8 x 30

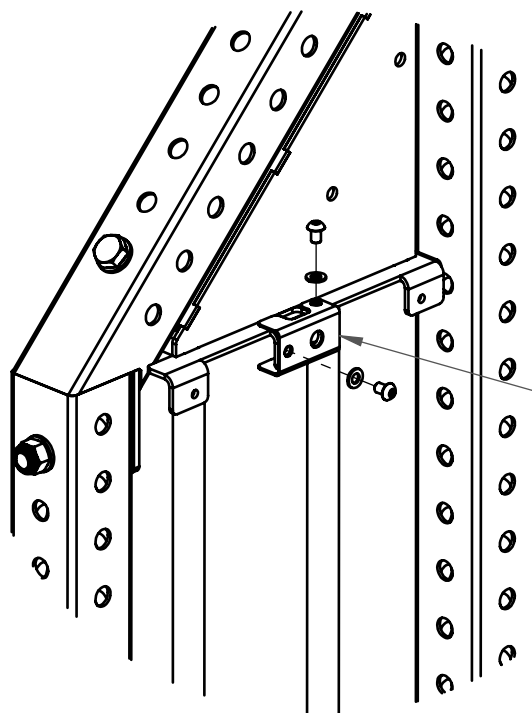

3085601 p6

THE WEIGHT INCREMENT CAN NOW BE SECURED
IN A TOP POSITION WITH HELP OF THE POP-PIN!

13.

1x



Single Wheel Kit

1x

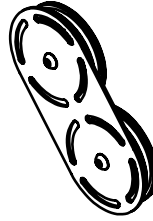

Double Wheel Kit

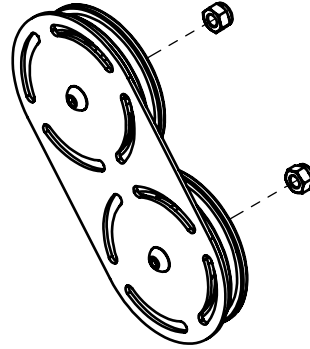
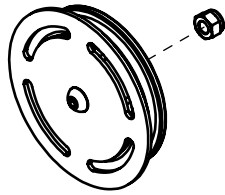

UNSCREW NUTS AND MOUNT BOTH WHEEL KITS!

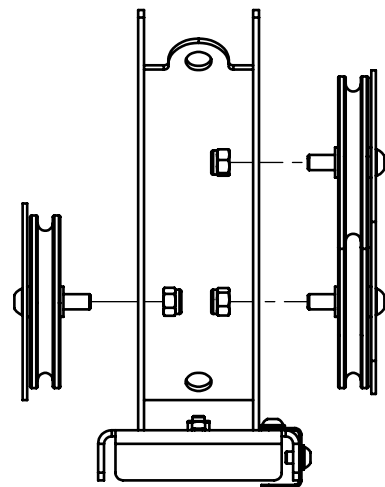
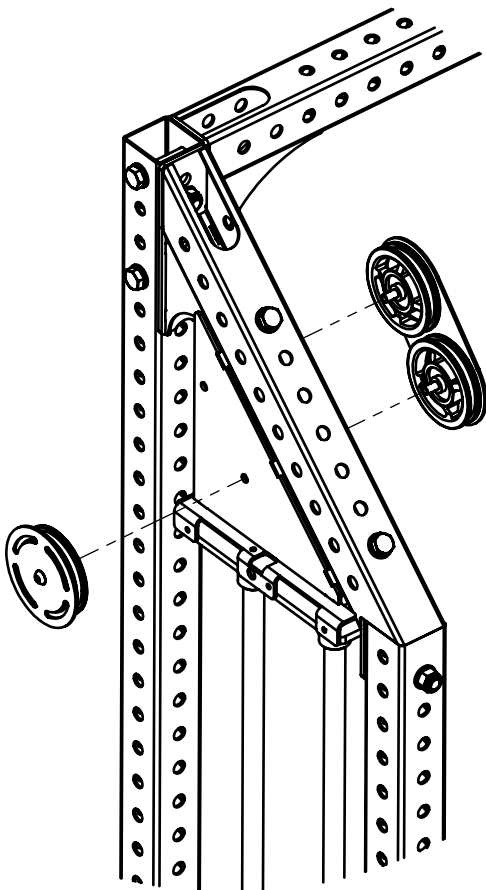

14.

1x



3085601 a9

MOUNT THE TOP WHEEL ONE SCREW AT THE TIME!
START WITH THE TOP ONE!

USE EXISTING SCREW WITHOUT
WASHER ON THIS SIDE!

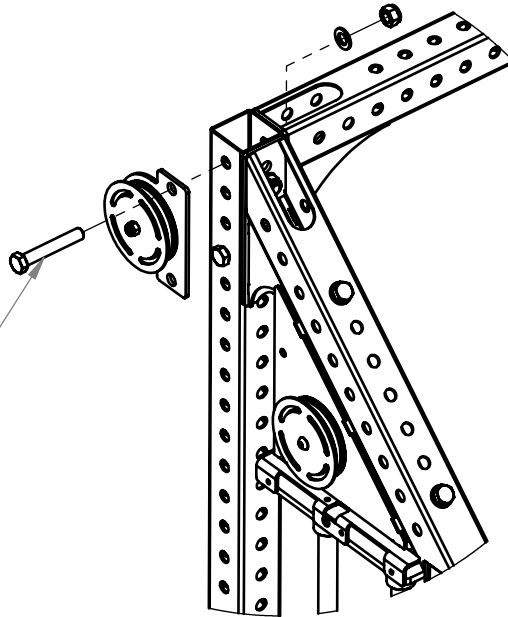

USE EXISTING SCREW WITHOUT
WASHER ON THIS SIDE!

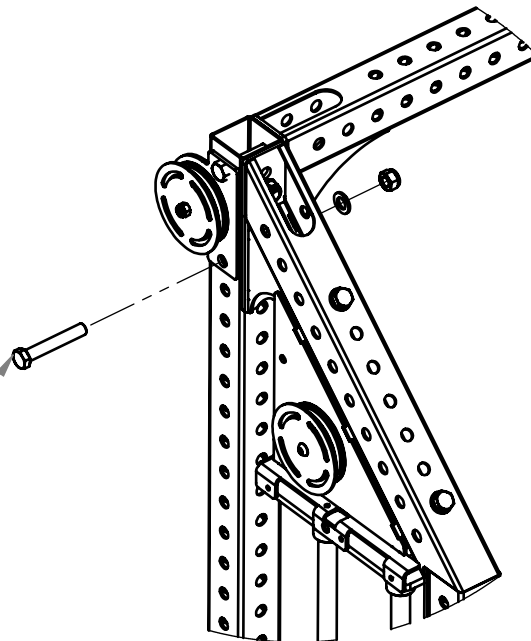

15.

1x

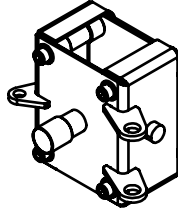

3085601 a3

REMOVE PLATE AND REASSEMBLE ON UPRIGHT!
BE CAREFUL NOT TO LET ANY PARTS FALL OUT!

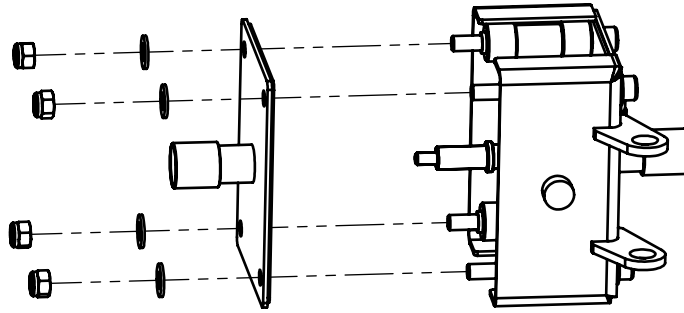

MAKE SURE THE SCREWS ARE NOT TOO TIGHT!
CARRIAGE SHOULD BE EASY TO ADJUST IN HEIGHT!

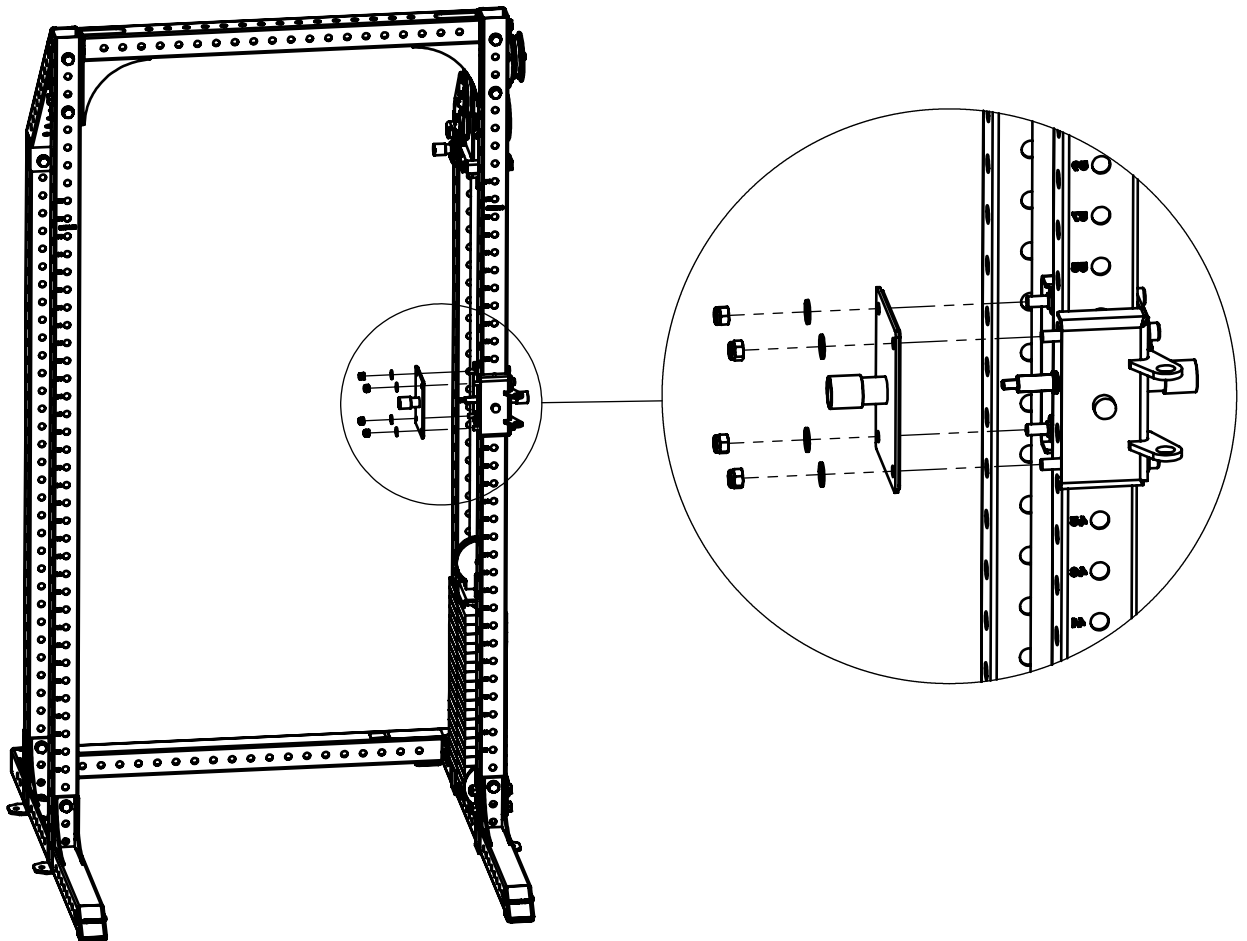

16.

1x



3085601 a6

2x



2001000

1x

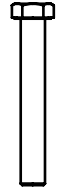

M16 x 110

2x



Washer M16

1x



Locking Nut M16

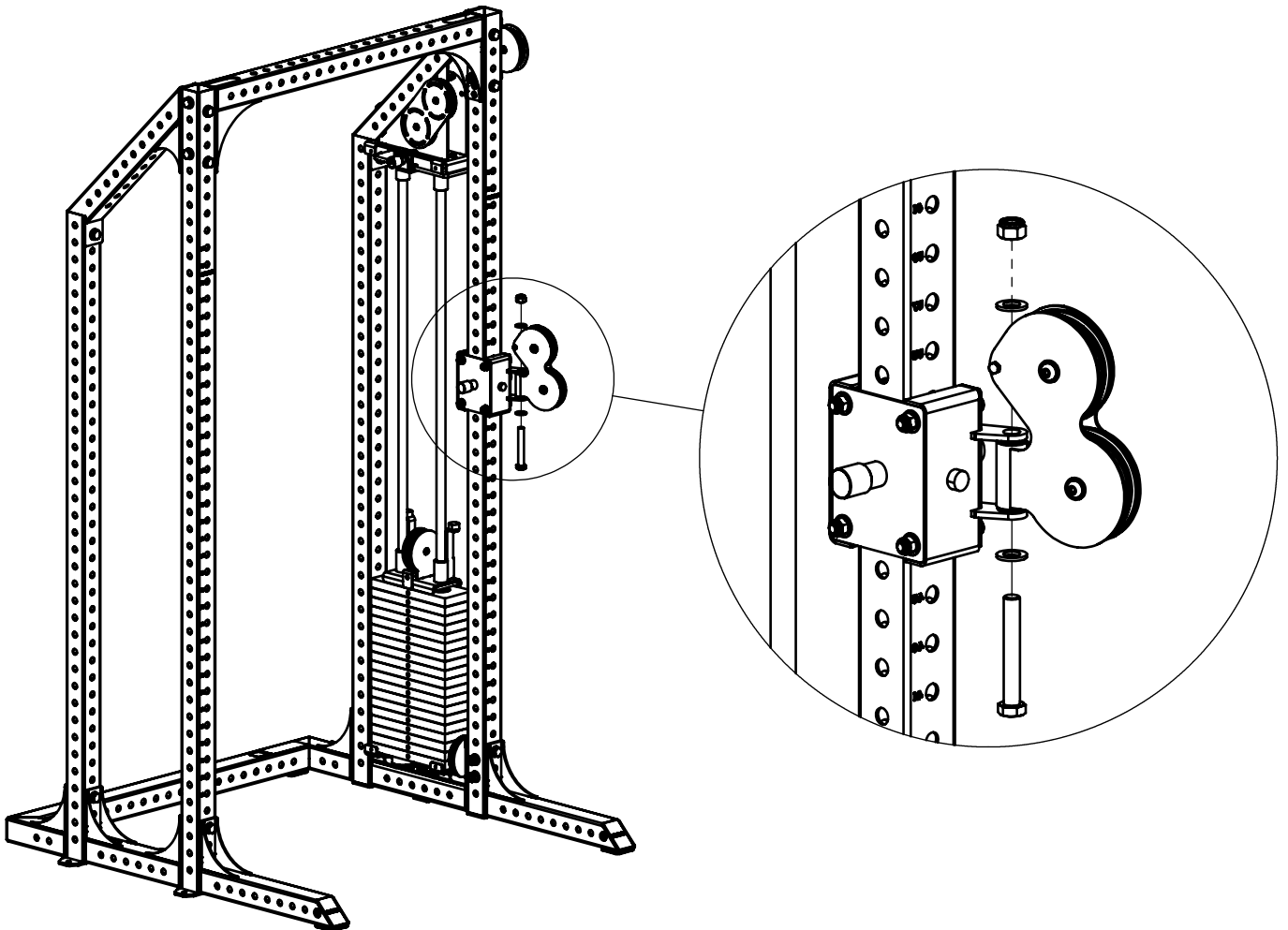
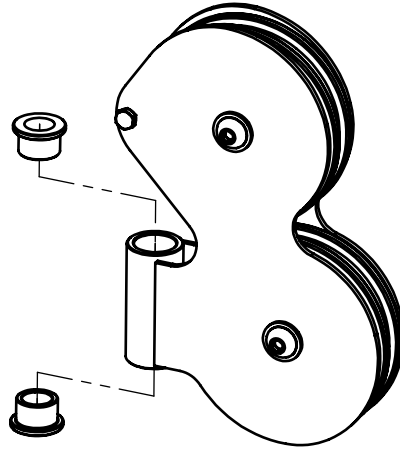

17.

1x



Hollow Screw

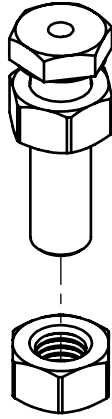

UNSCREW NUT AND MOUNT ON CARRIAGE!

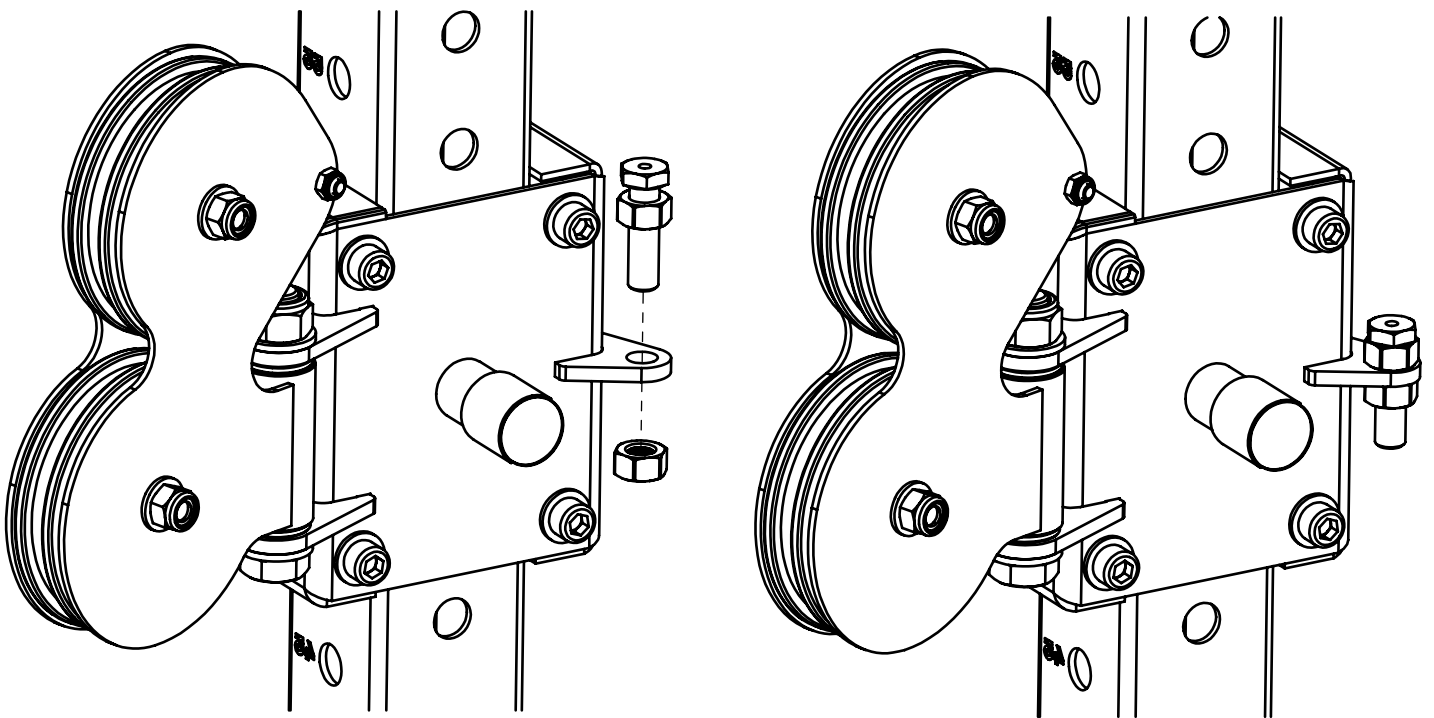

SCREW SHOULD BE AS FAR DOWN AS POSSIBLE!
TENSION IN THE CABLE CAN LATER BE ADJUSTED BY MOVING THE SCREW UPWARDS!

18a.

1x

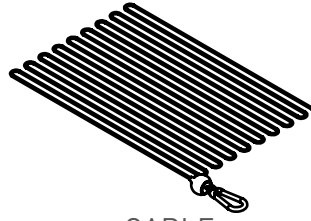

CABLE

Step 1

LET CABLE PASS INSIDE THIS SCREW!

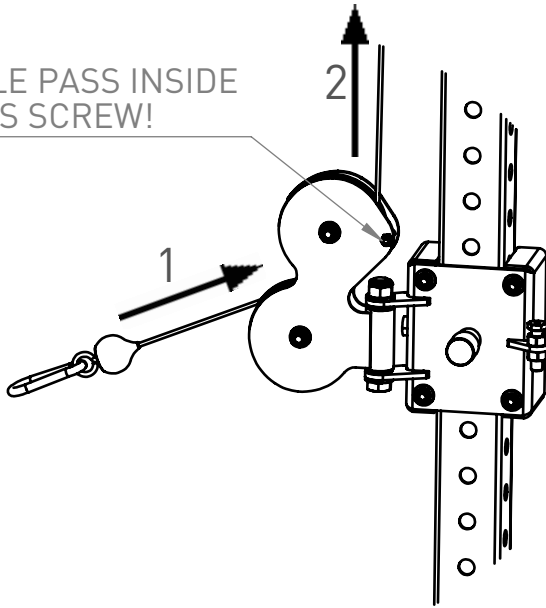

Step 2

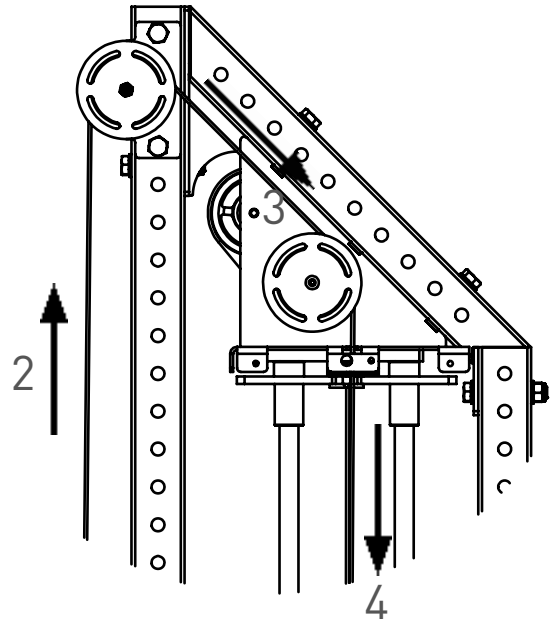

Step 3

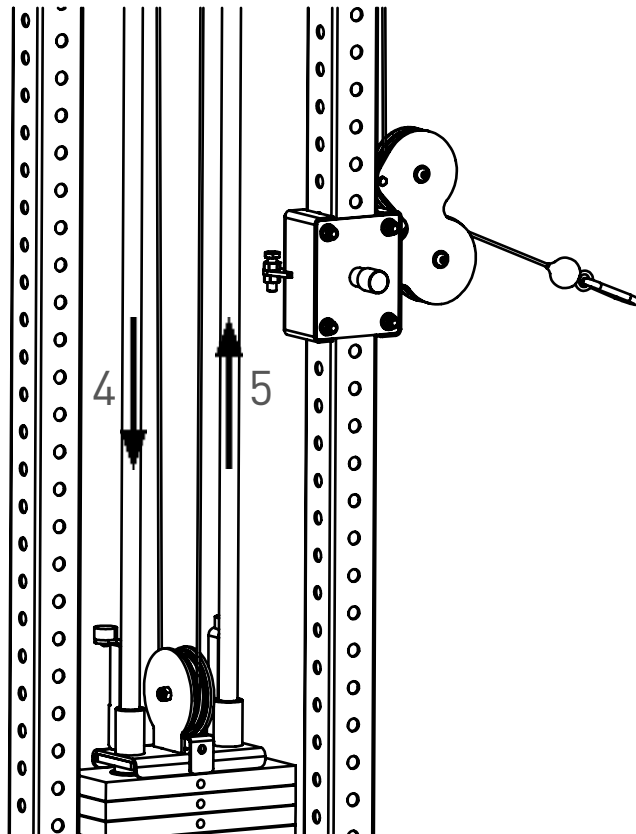

18b.

1x



2001808

Step 4

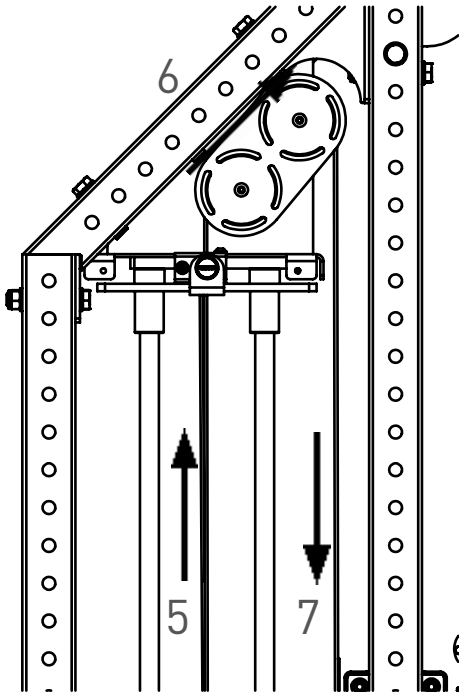

Step 5

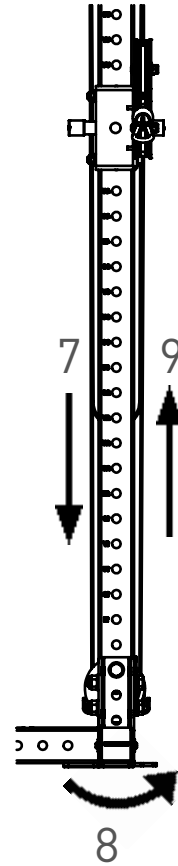

Step 6

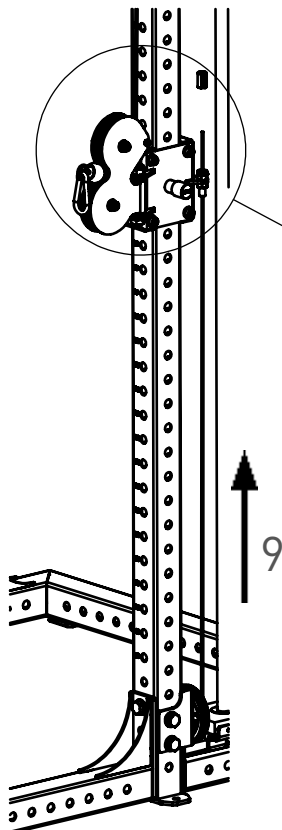

MAKE SURE THE CABLE IS TIGHT BY PULLING ITS END.
LET THE CABLE PASS THROUGH THE HOLLOW SCREW
BEFORE FIXING IT WITH THE CABLE END!
CUT OFF LEFTOVERS FROM CABLE!

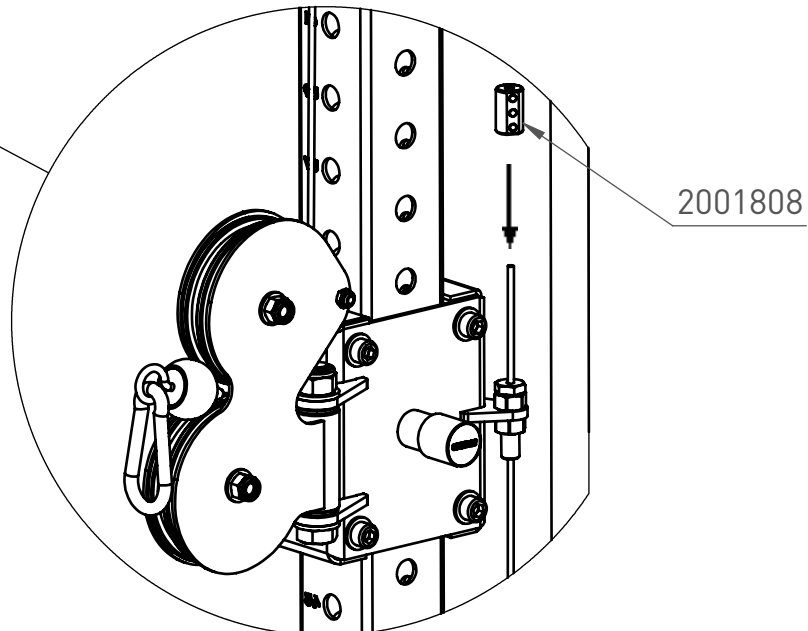

2001808

19.

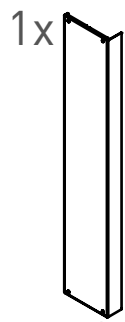

3085601 p25 / 3085709 p2



K6S M8 x 12



Washer M8

WIPE OFF BOTH RODS AGAIN WITH A CLEAN CLOTH
BEFORE MOUNTING COVER PLATE!

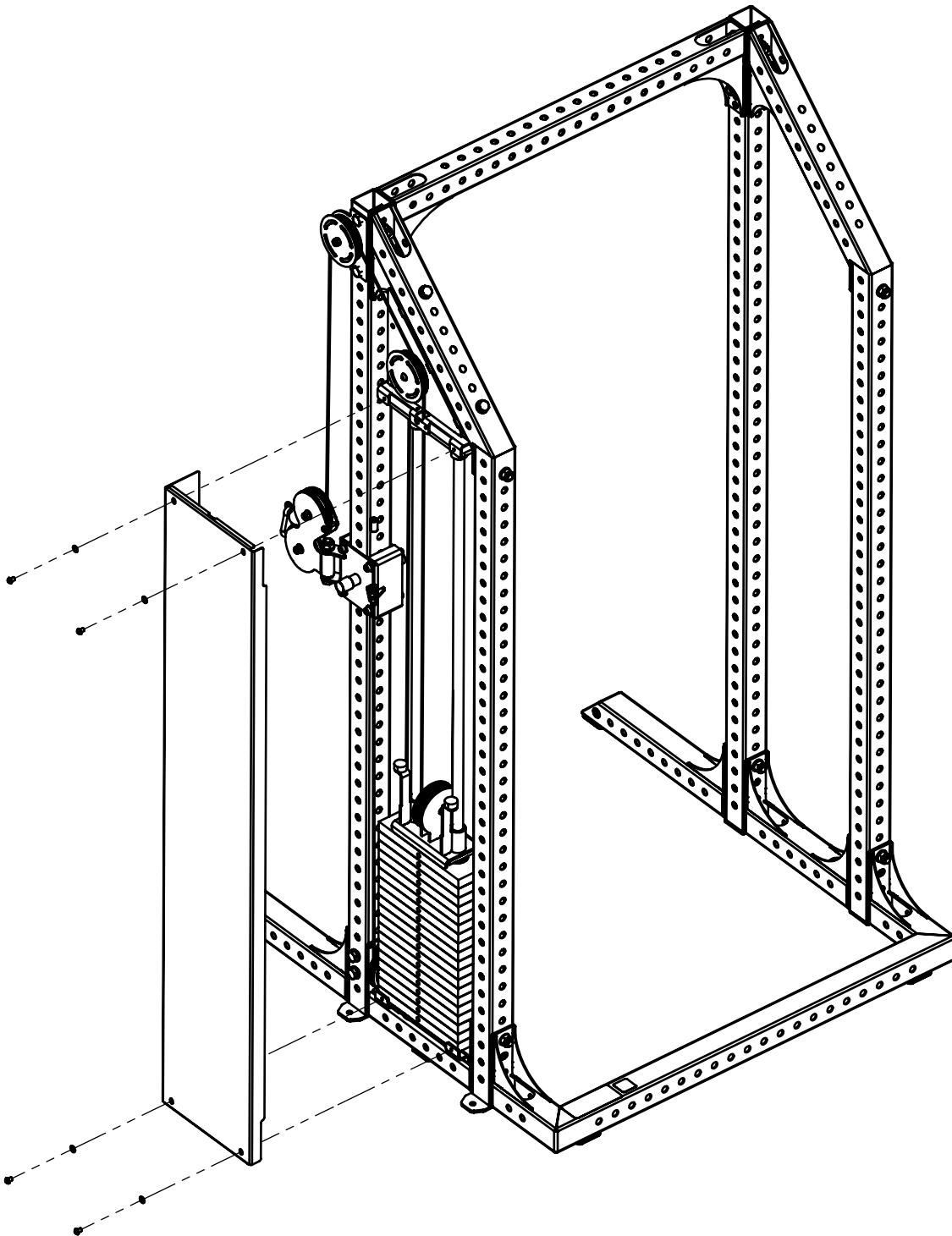

20.

1x

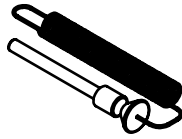

2001483

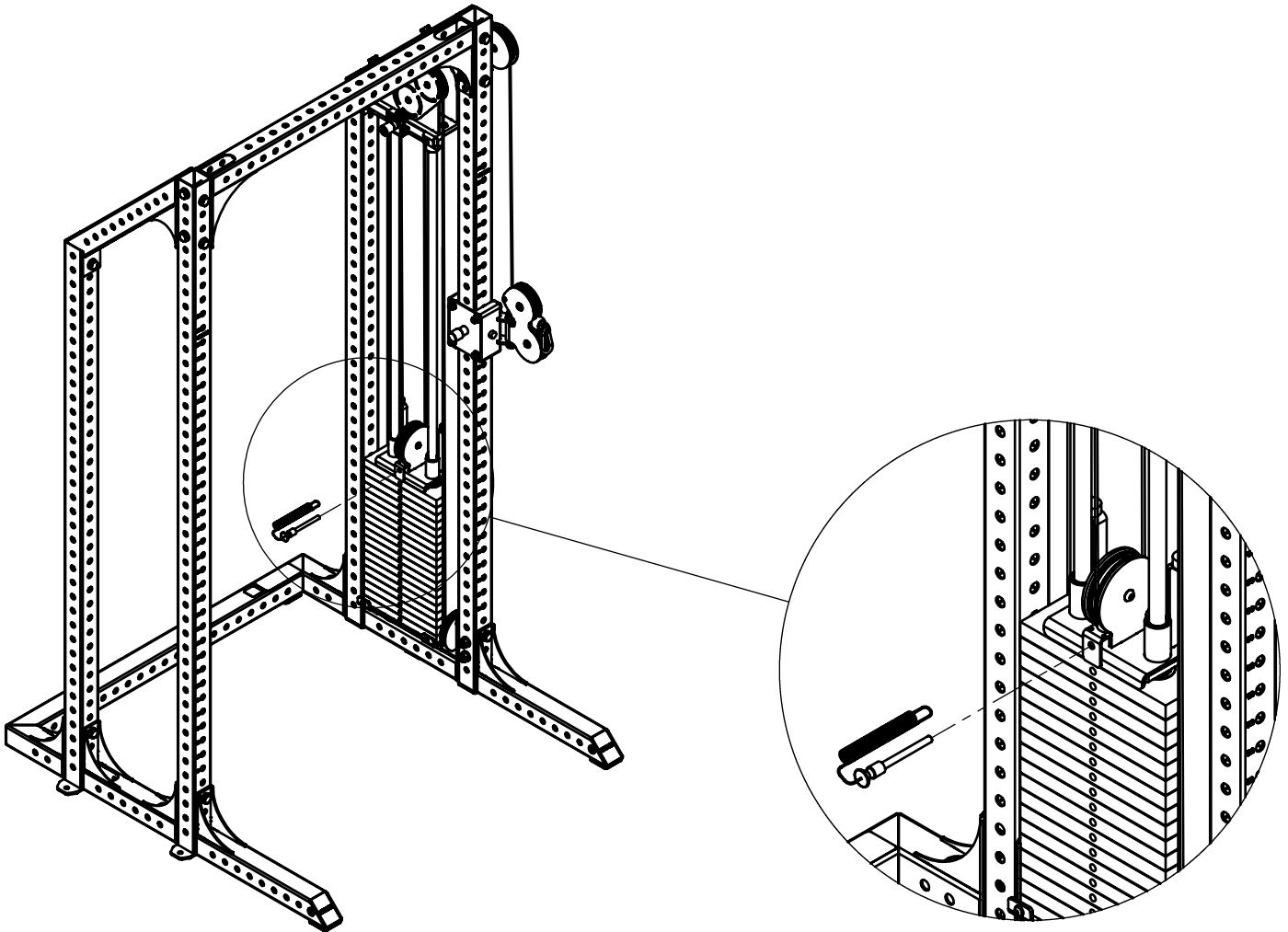

SECURE SELECTOR PIN BY THREADING THE METAL RING INTO THE LEFT HOLE!

21.

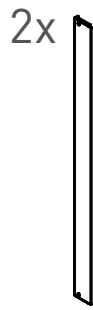

3085601 p11 / 3085709 p1

K6S M8 x 12

Washer M8

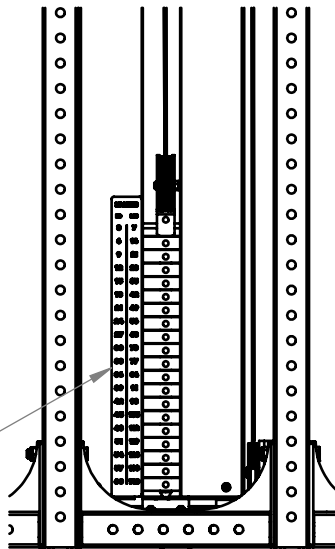
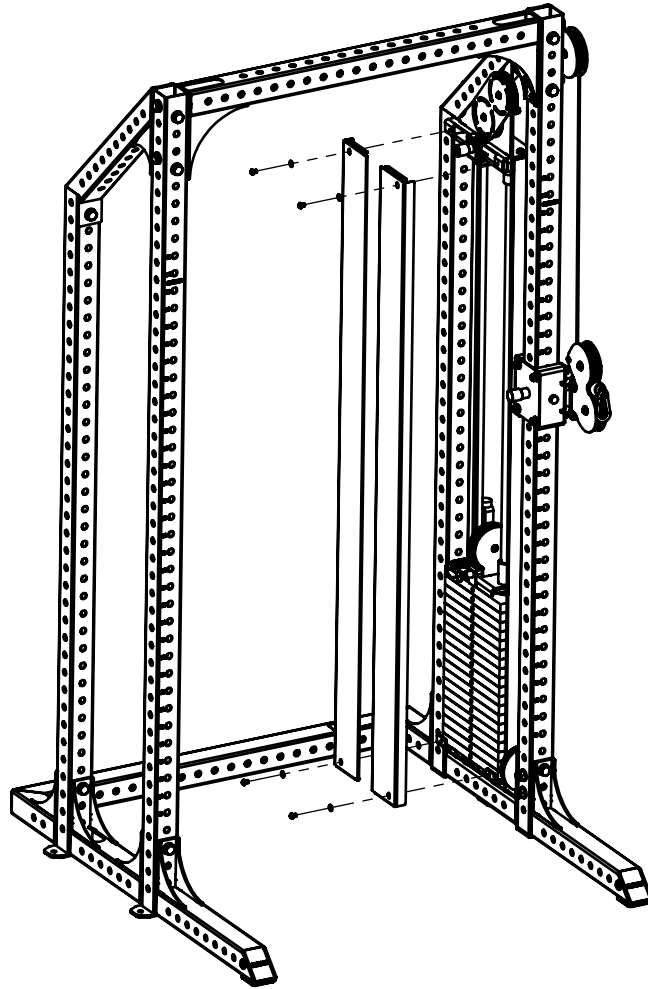

NUMBERS TO THE LEFT OF THE WEIGHT STACK!

THIS STEP ONLY APPLIES IF YOU HAVE STORAGE PINS!

22.

4x



3061757 p30

or

8x



3061757 p30

FOR ELEIKO PRESTERA STORAGE PINS, USE EXISTING RUBBER DAMPERS TOGETHER WITH FOUR NEW DAMPERS RECEIVED WITH ELEIKO PRESTERA CALBE ATTACHMENT! YOU WILL NOT NEED THE REMAINING FOUR DAMPERS!

4x

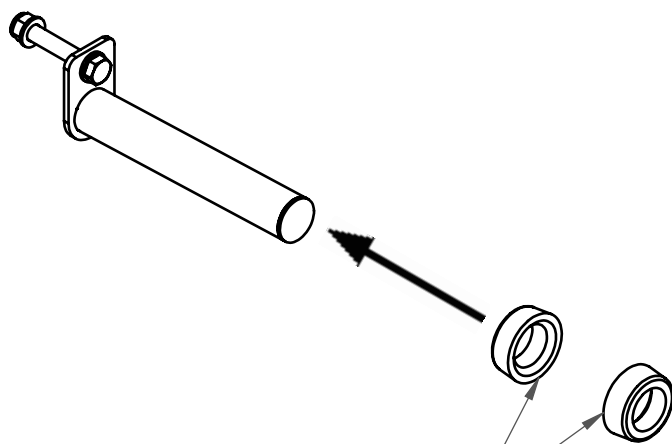

LARGE ENDS AGAINST EACH OTHER!

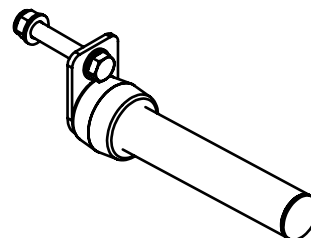

FOR ELEIKO PRESTERA CHROMED STORAGE PINS, USE ALL EIGHT DAMPERS RECEIVED WITH ELEIKO PRESTERA CALBE ATTACHMENT!

4x

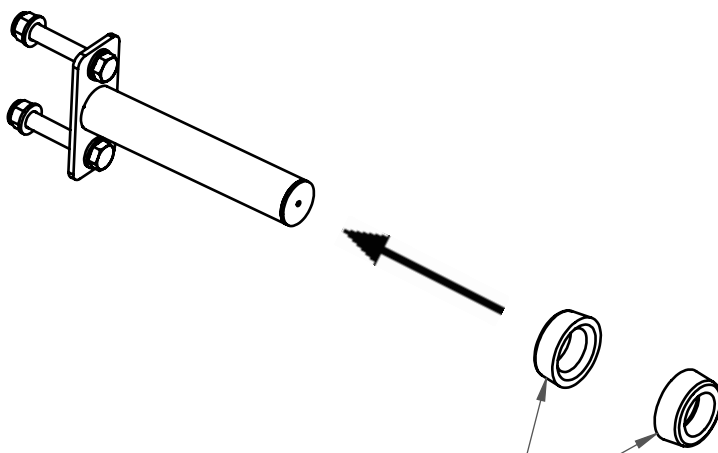

LARGE ENDS AGAINST EACH OTHER!

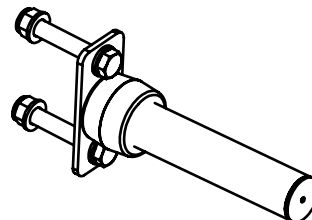

USER GUIDE

PURPOSE

Cable attachment that enables a variety of exercises in a Eleiko Prestera Rack.

GENERAL INSTRUCTIONS FOR USE

1. Use the selector pin to select training weight.
2. Adjust height on carriage by pulling the pop-pin.
3. Switch to different handles depending on exercise.
4. Release 1,5 kg / 3,5 lbs weight increment by pulling pop-pin.
5. Adjust tension in cable with help of the hollow screw. See step 17 on page 28 and 57.

PRODUCT SPECIFICATION

Max training weight

3085850 90 kg / 198 lbs

3085601 & 3085709 120 kg / 265 lbs

Dimensions (L x W x H)

3085601 & 3085850 669 x 188 x 2331 mm / 26 x 7 x 92"

3085709 669 x 188 x 2581 mm / 26 x 7 x 102"

Product weight:

3085601 185 kg / 408 lbs

3085709 189 kg / 417 lbs

3085850 155 kg / 342 lbs

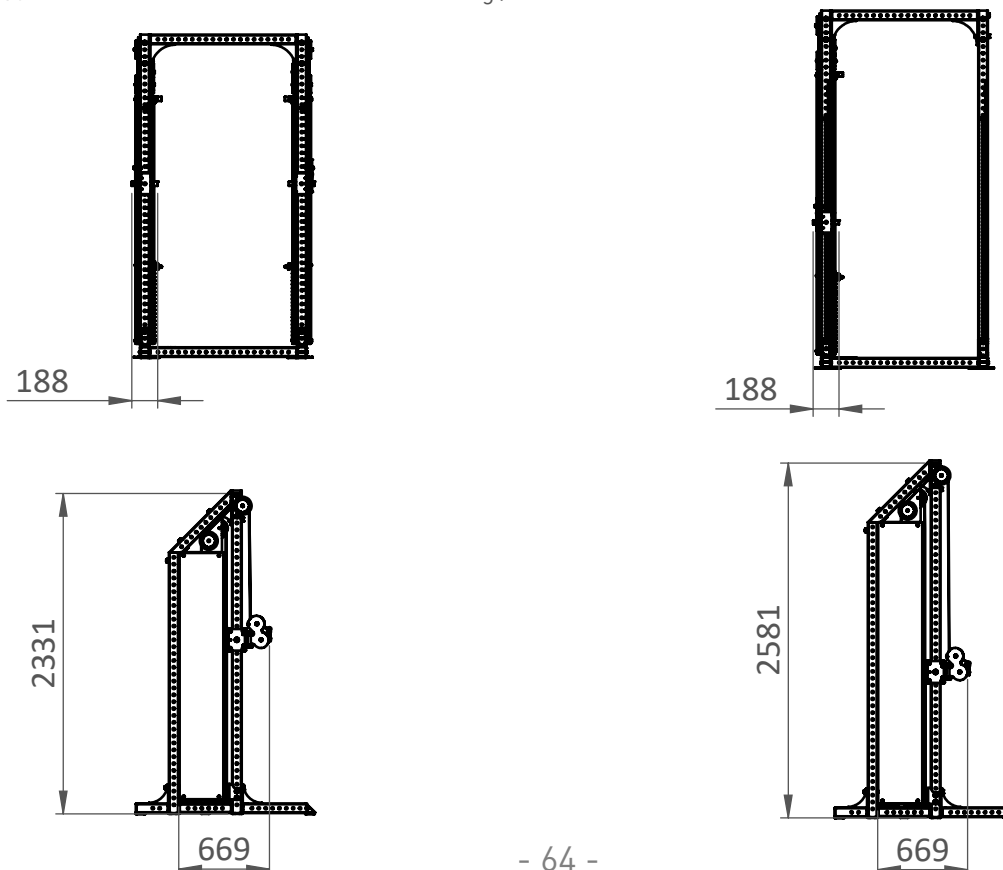

CARE AND MAINTENANCE

PREVENTIVE MAINTENANCE AND INSPECTIONS

NOTE: The safety level of the equipment can only be maintained if it is examined regularly for damage and wear.

Regularly:

- Clean surfaces on the frames and tubes from dust and dirt.
- Check that all bolts between parts, walls and floors are properly tightened, according to recommendations.
- Check equipment for sharp edges. Replace parts with sharp edges.

See also www.eleiko.com.

SPARE PARTS AND SERVICE

The following components are parts that are not listed in the list of components section. They may however need to be replaced eventually. The rest of the components can be found in the list of components section.

Plastic Protection

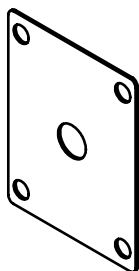

3085570 p6

Plastic Roller

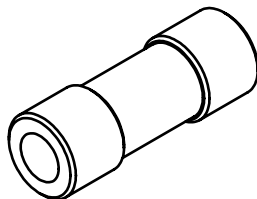

3085570 p38

Spring

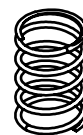

2001445

Locking Nut M10



2001624

Plunger Pin

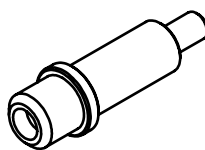

3085466 p17

Knurled Knob

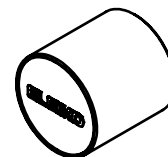

2001345

Contact Eleiko for spare parts and service:

Eleiko Group AB | Klastorpsvägen 18 | SE-302 62 HALMSTAD | Sweden
E-mail: info@eleiko.com | Phone: +46 35 17 70 70
www.eleiko.com

WARRANTY

All products manufactured by ELEIKO are warranted to the original purchaser to be free from defects in workmanship and / or materials under normal use or service as follows:

- 5 years on structural moving parts.
- 3 years on bearing, bushings and pulleys.
- 1 year on cable and accessories.

ELEIKO

Eleiko Group AB | Klastorpsvägen 18 | SE-302 62 HALMSTAD | Sweden
E-mail: info@eleiko.com | Phone: +46 35 17 70 70

www.eleiko.com