

ELEIKO PRESTERA POWER RACK

Art.no. 3085467, 3085550, 3085635, 3085723

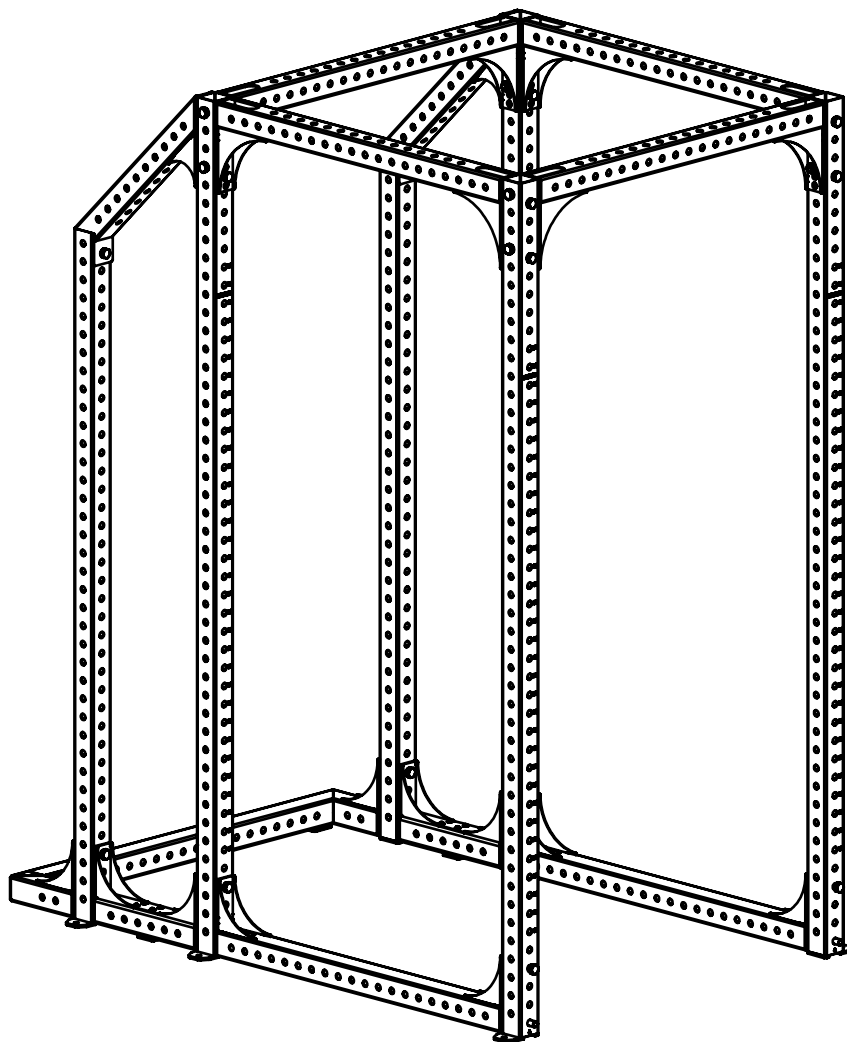

ELEIKO

CONTENTS

Read before installation and use	3
Safety instructions	3
Warning labels	4
Bolt to ground	5
List of components	6
Assembly instructions	9
Tools needed	9
User guide	30
Purpose	30
General instructions for use	30
Product specifications	30
Care and maintenance	31
Preventive maintenance and inspections	31
Spare parts and service	31
Warranty	31

READ BEFORE INSTALLATION AND USE

Install and use this equipment in a place where access and supervision are specifically controlled by the owner.

Be sure to install the equipment on a stable base and level the equipment properly. Eleiko recommends that all equipment is secured to floor and installed by a licensed contractor or an Eleiko installer.

This equipment is intended for indoor use only.

SAFETY INSTRUCTIONS

It is the responsibility of the purchaser of ELEIKO products to instruct all users and supervising personnel on proper usage of the equipment.

1. All included warnings (labels) and instructions **MUST** be read before the use of any Eleiko equipment. Only use the equipment as it is intended.
2. A user **MUST** get a medical examination and proper instructions before using any Eleiko equipment.
3. **DO NOT** let anyone, under any circumstances, use equipment that appears to be damaged. Do not try to repair any equipment before consulting an Eleiko technician.
4. **DO NOT** replace components of Eleiko equipment with other, none Eleiko, equipment (magnetic safety pin, frames, bars etc.). Do not improvise! If there are any doubts, consult an Eleiko representative prior to any intervention.
5. **DO NOT** overload the equipment and **DO NOT** try to exceed personal strength levels.
6. Children under the age of 14 must be supervised by an adult.
7. **DO NOT** remove any safety labels from the Eleiko equipment. Eleiko is not responsible if a label is removed. Replace damaged labels immediately.
8. Eleiko packaging for products can be made of wood. Be aware of splinters! You **MUST** use protective gloves and proper work wear.
9. Eleiko packaging material could be a risk when handling. Be aware of crushing! You **MUST** use work wear including protective gloves and hard shoes.
10. Eleiko products and packing material are heavy, You **MUST** use proper lifting techniques, work wear and hard shoes.

WARNING LABELS

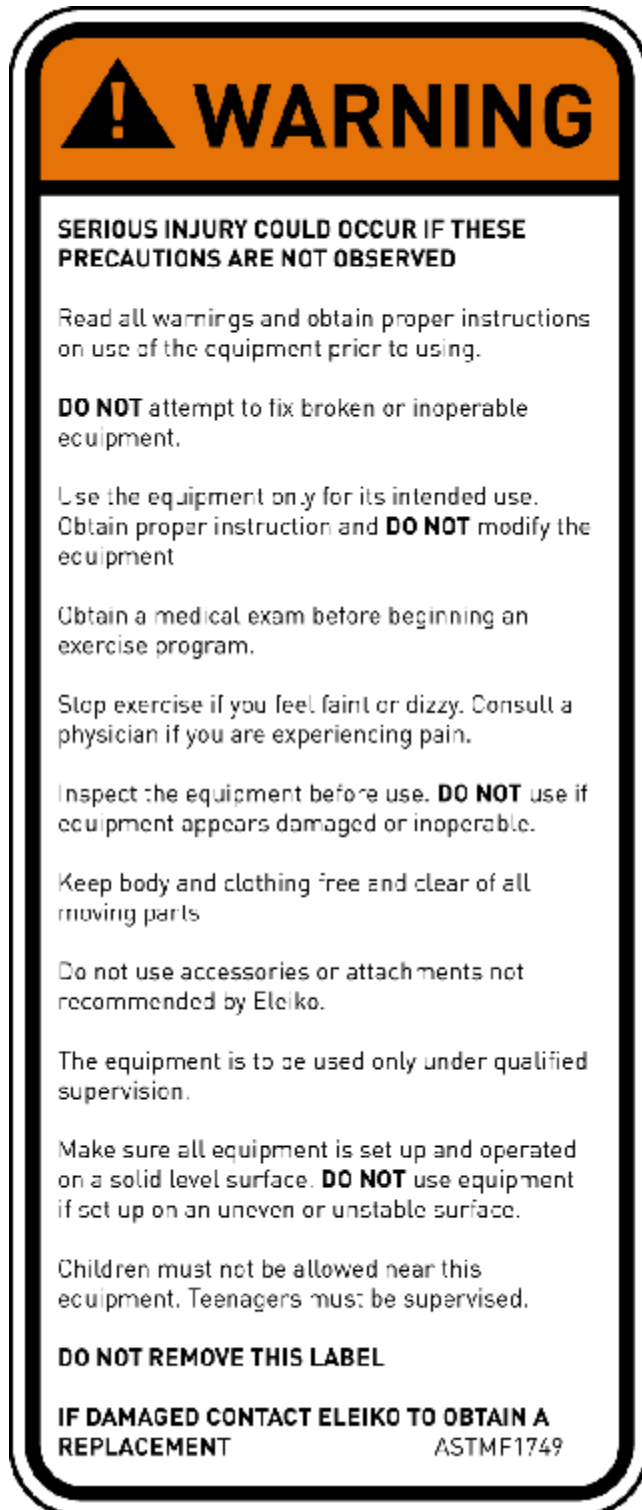

BOLT TO GROUND

This product needs to be bolted to the ground. Make sure the ground is solid and level. Consult a licensed contractor to choose the appropriate anchoring fasteners for your facility.

See last page of assembly instructions for the anchoring points positions.

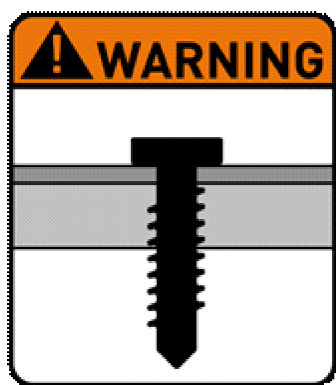

LIST OF COMPONENTS

ELEIKO PRESTERA POWER RACK

Art.no 3085467, 3085550

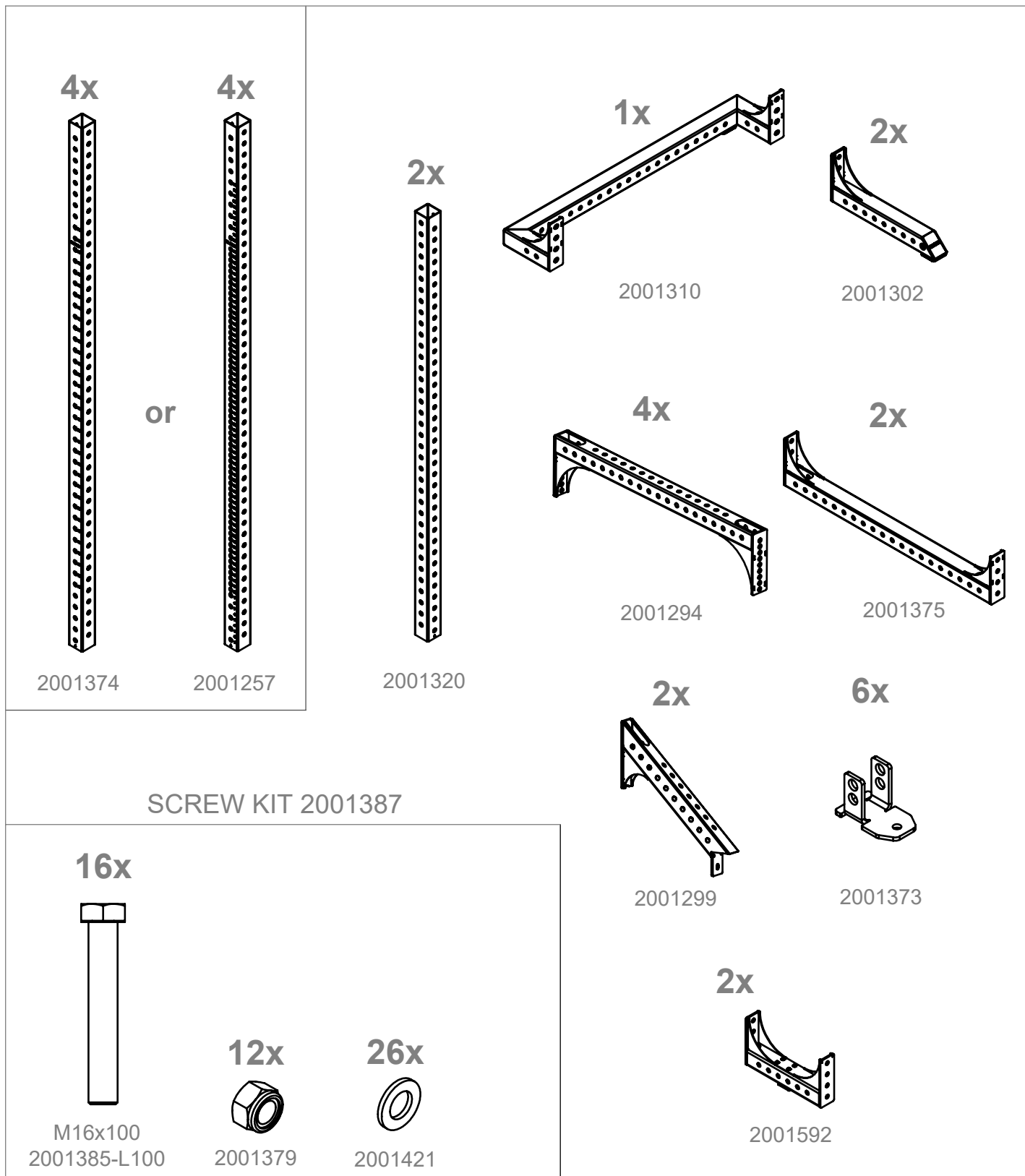

LIST OF COMPONENTS

ELEIKO PRESTERA POWER RACK - SHORT

Art.no 3085635

4x

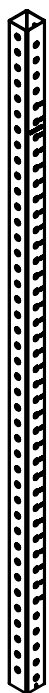

2001548

2x



2001549

1x

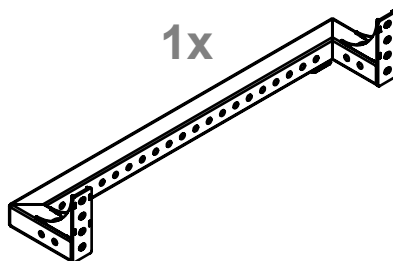

2001310

4x

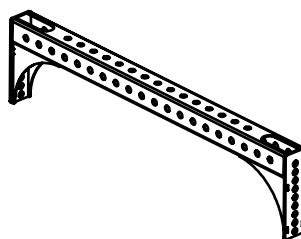

2001294

2x

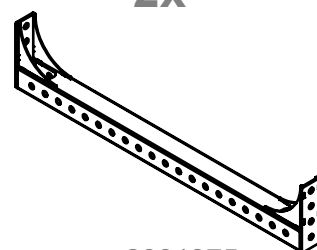

2001375

SCREW KIT 2001387

16x

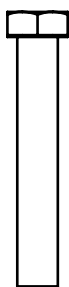

M16x100
2001385-L100

12x



2001379

26x



2001421

2x

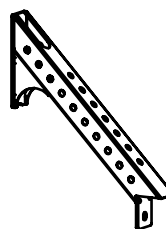

2001299

6x

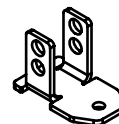

2001373

2x

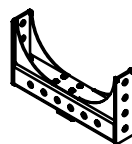

2001592

2x

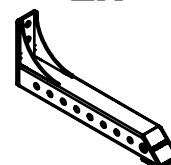

2001302

LIST OF COMPONENTS

ELEIKO PRESTERA POWER RACK - TALL

Art.no 3085723

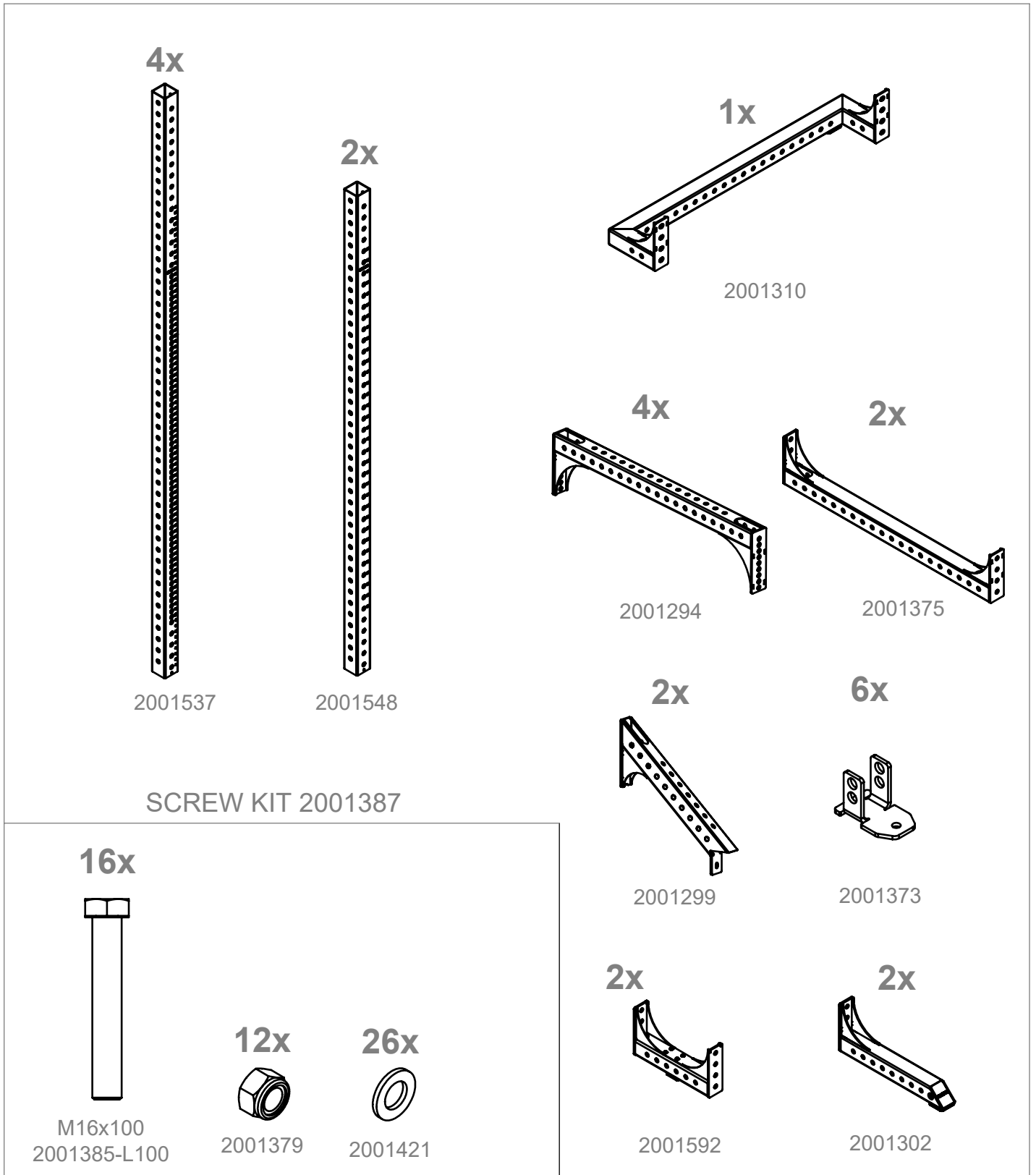

ASSEMBLY INSTRUCTIONS

Before assembly, make sure you have enough clearance on all sides of the equipment, not less than 0,6 meters. Take in account the accessibility to remove and replace bar and weights.

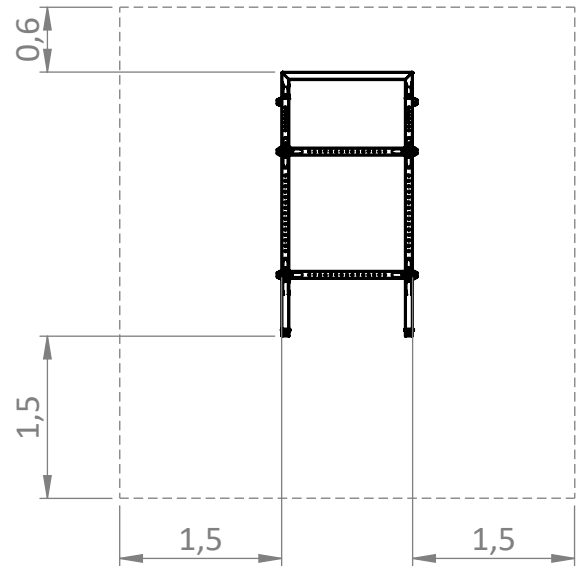

TOOLS NEEDED

You need the following tools to assemble the equipment.

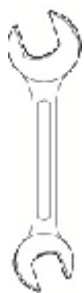

Wrench
24 mm



Socket Wrench
24 mm

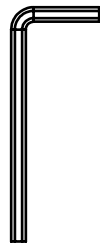

Allen Key Size 5

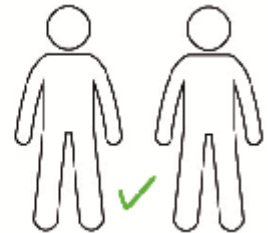

PREPARATION

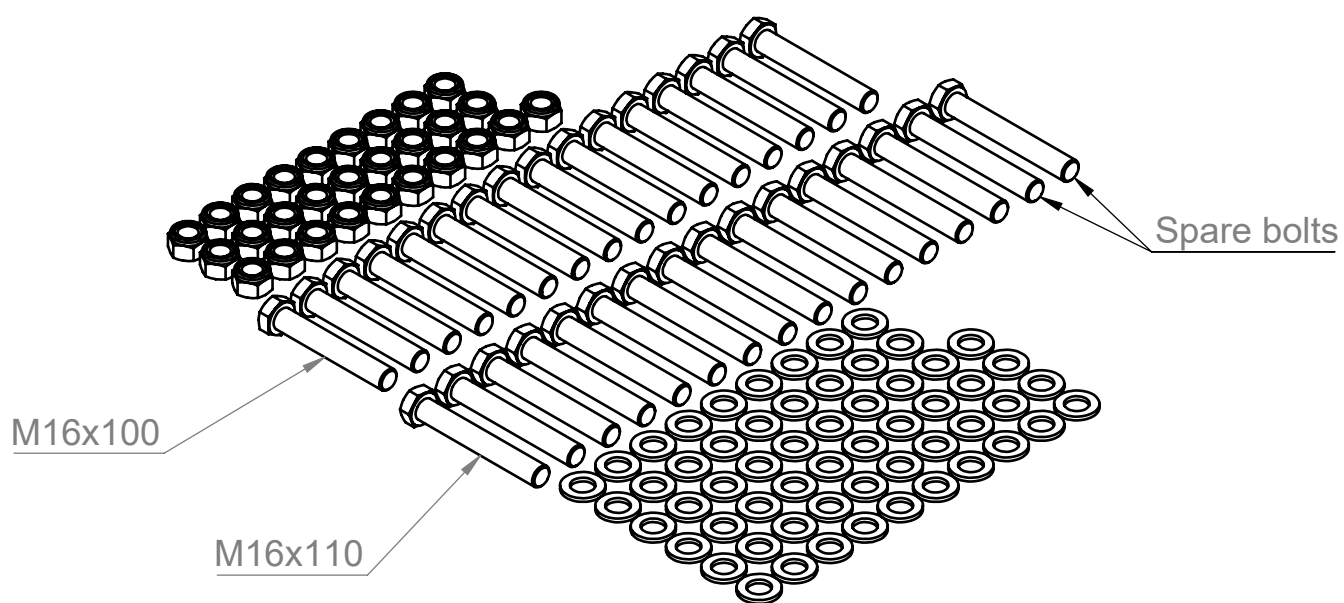

Note: Unbox 2001294 for additional bolts, locking nuts and washers

1.

1x

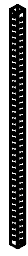

1x

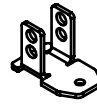

2001320 / 2001549 / 2001548

2001373

NOTE: USE THE SHORTER UPRIGHT!

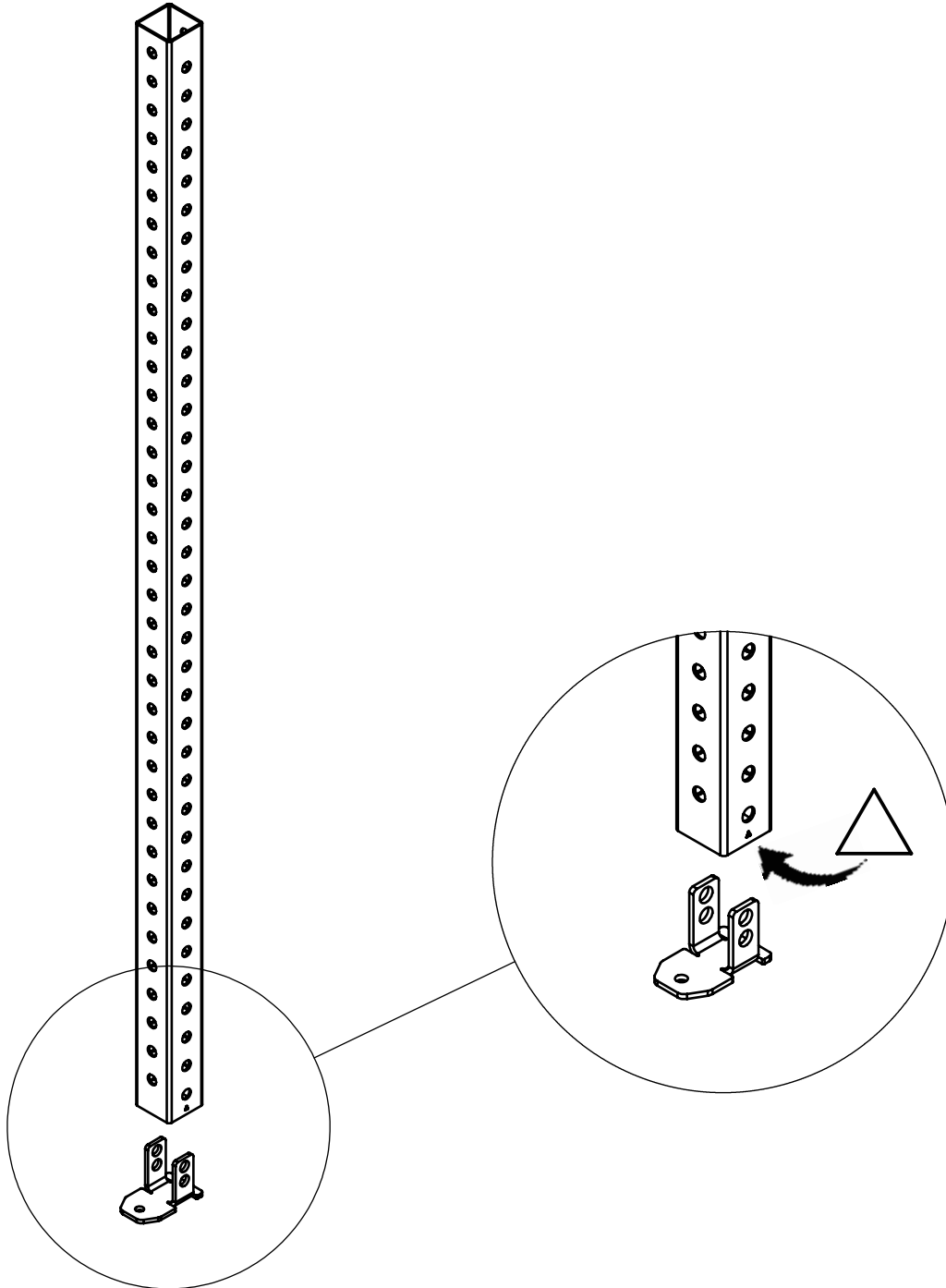

2a.

1x

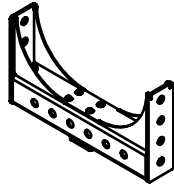

2001592

REMOVE COVER PLATES FROM FLOOR BEAMS!
SAVE ALL PARTS!

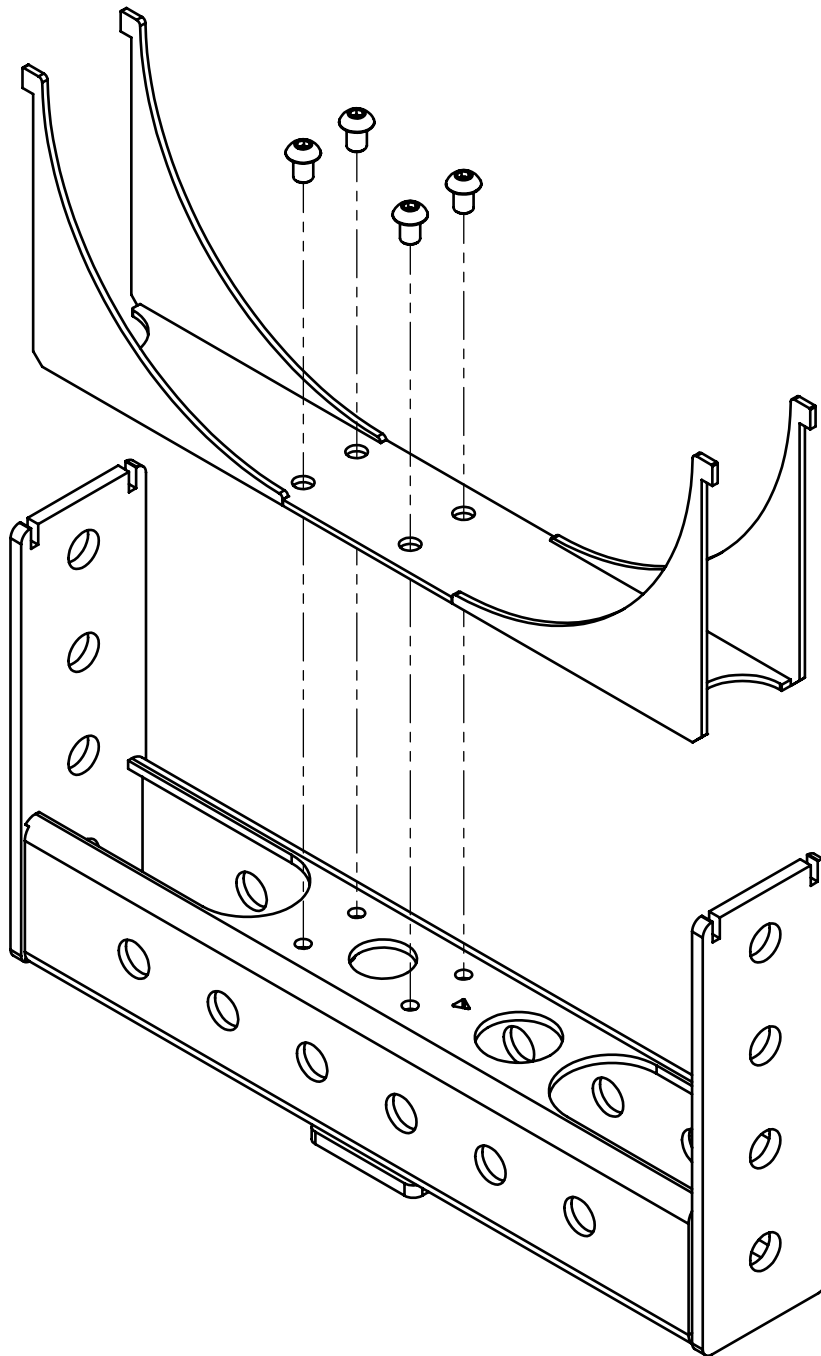

2b.

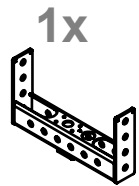

2001592

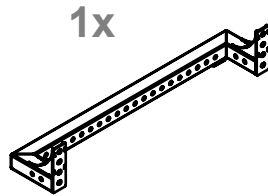

2001310

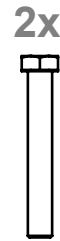

M16x110



2001379



2001421

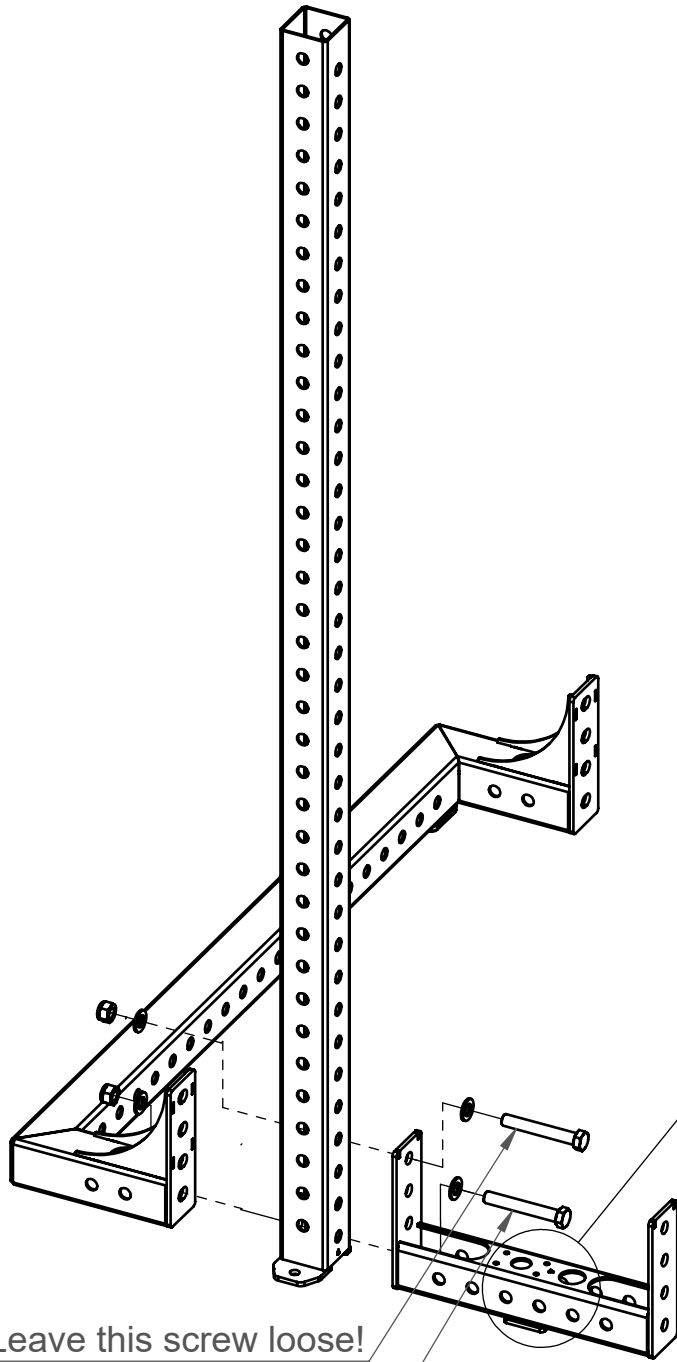

Leave this screw loose!

Tighten this screw!

TRIANGULAR CUT OUT SHOULD POINT TOWARDS THE FRONT OF THE RACK!

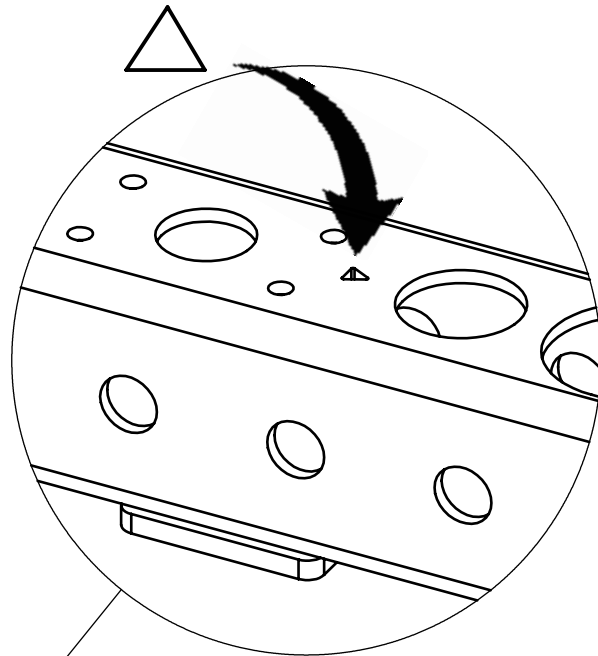

3.

1x



1x

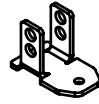

2001257 / 2001374 / 2001548 / 2001537

2001373

NOTE: USE THE TALLER UPRIGHT!

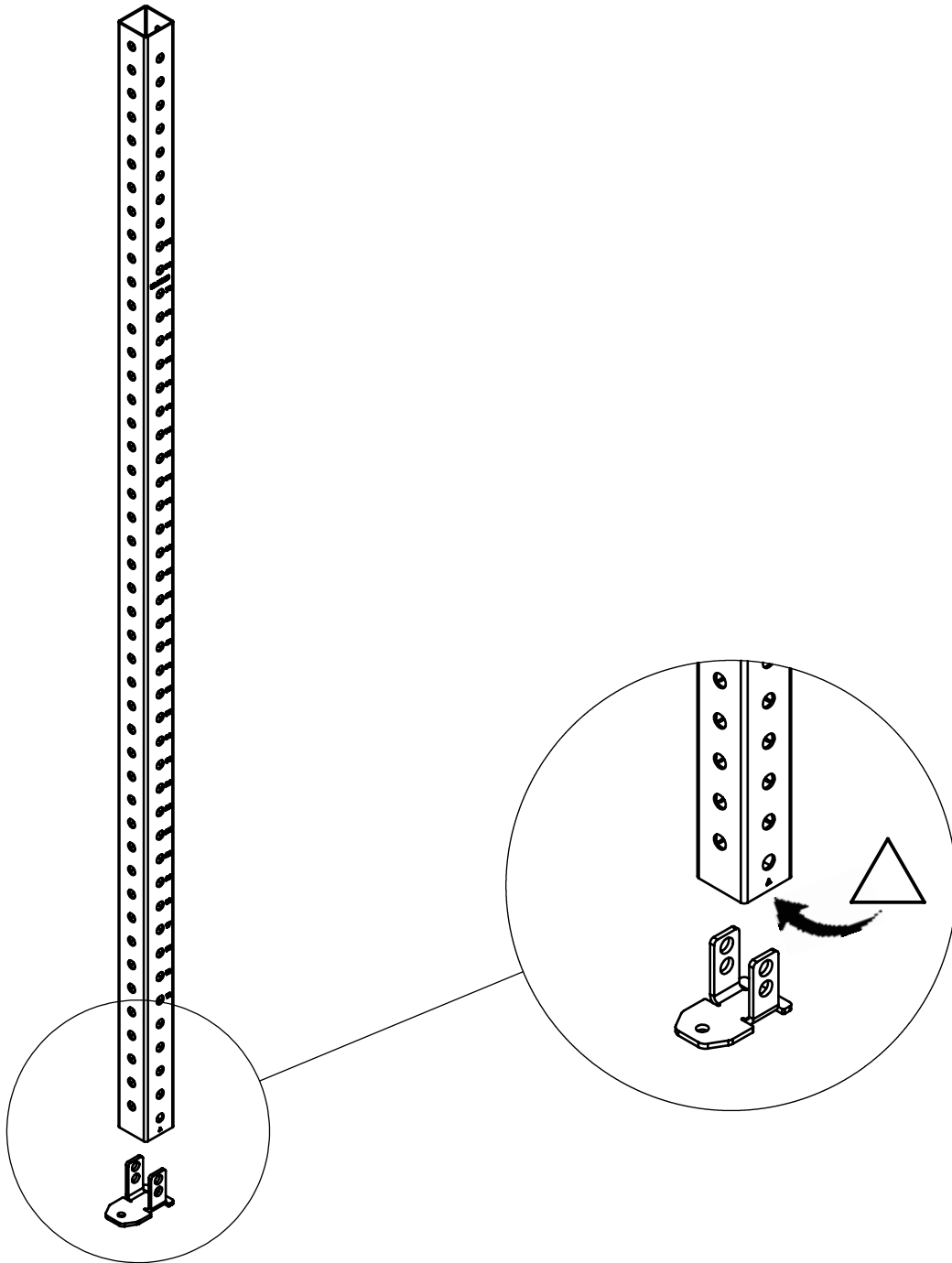

4a.

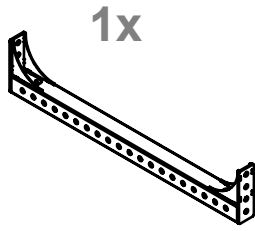

1x

2001375

2x



M16x110

4x



2001421

2x



2001379

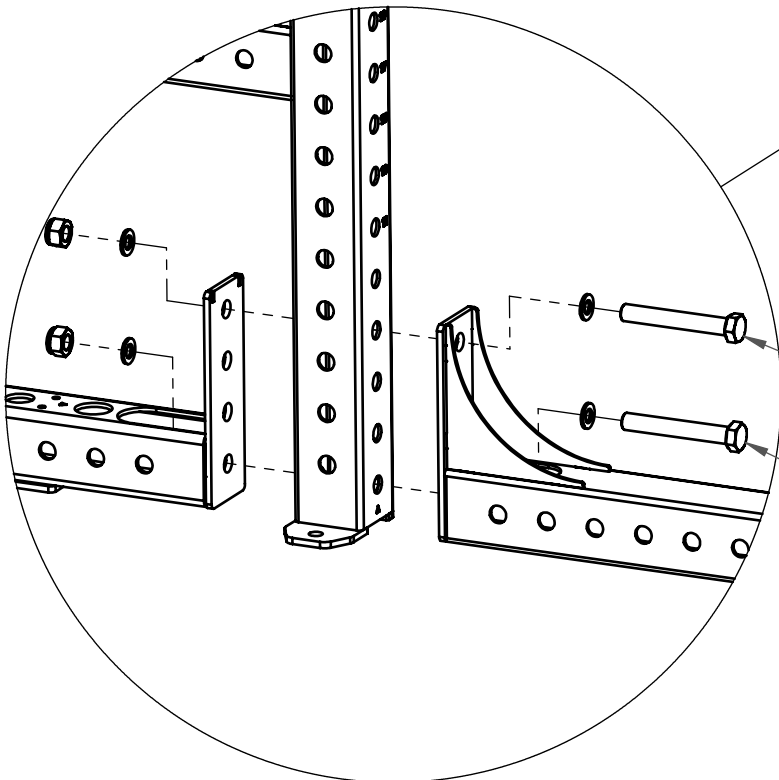
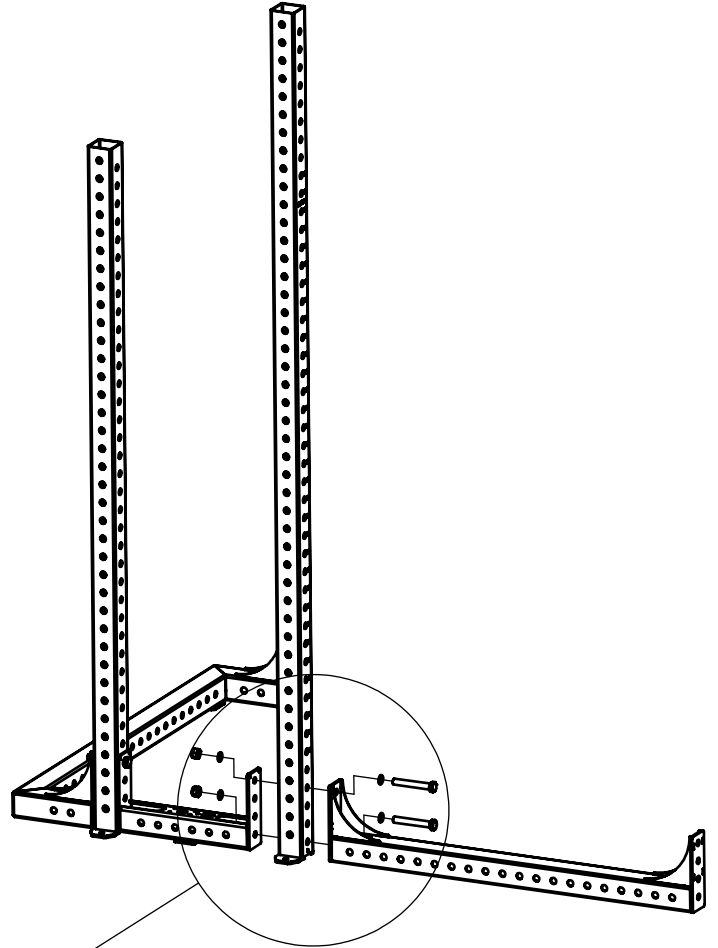

Leave this screw loose!

Tighten this screw!

4b.

PUT BACK COVER PLATE ON FLOOR BEAM!
USE PARTS FROM STEP 2a!

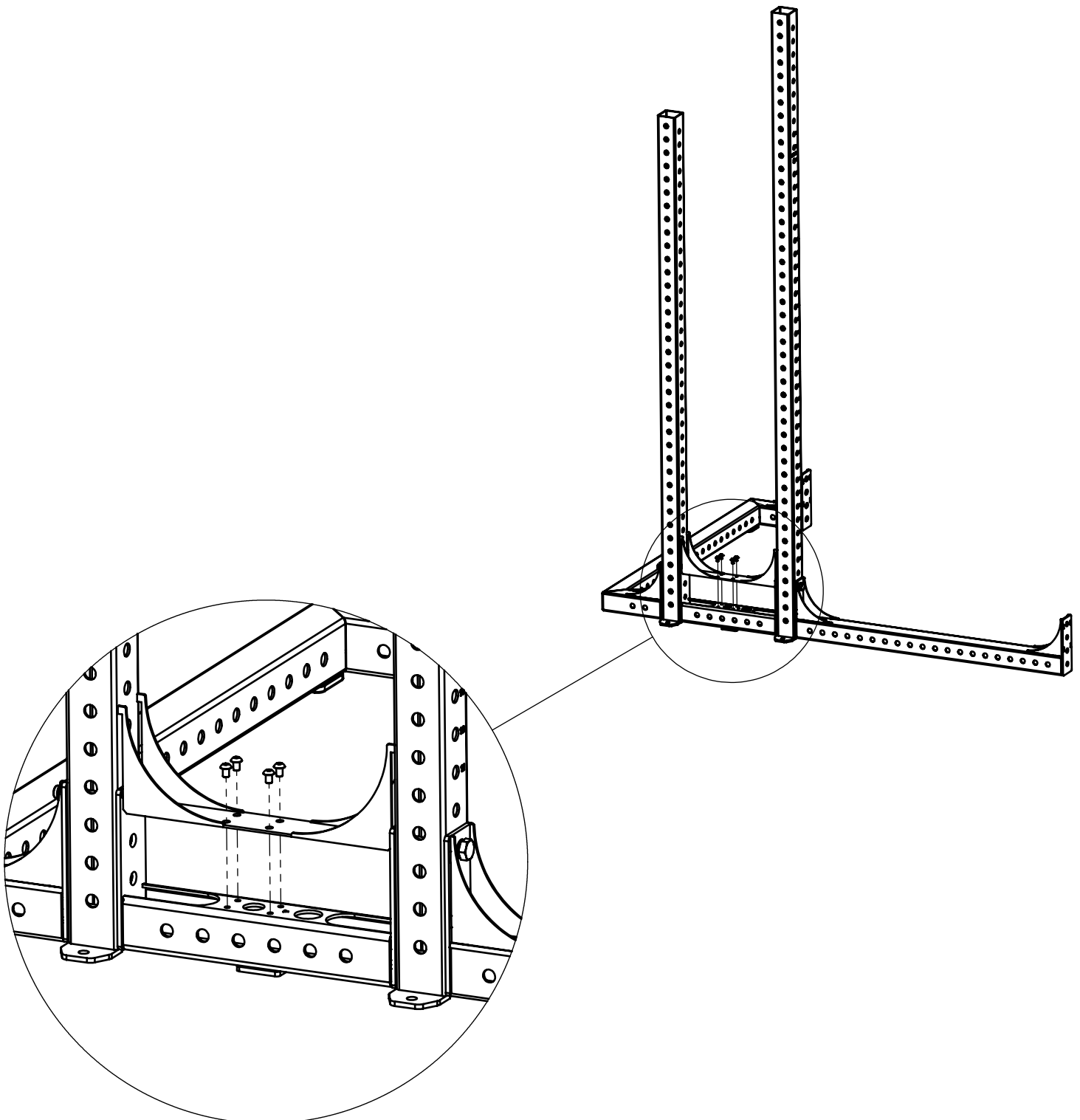

5.

1x



1x

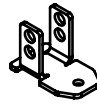

2001320 / 2001549 / 2001548

2001373

NOTE: USE THE SHORTER UPRIGHT!

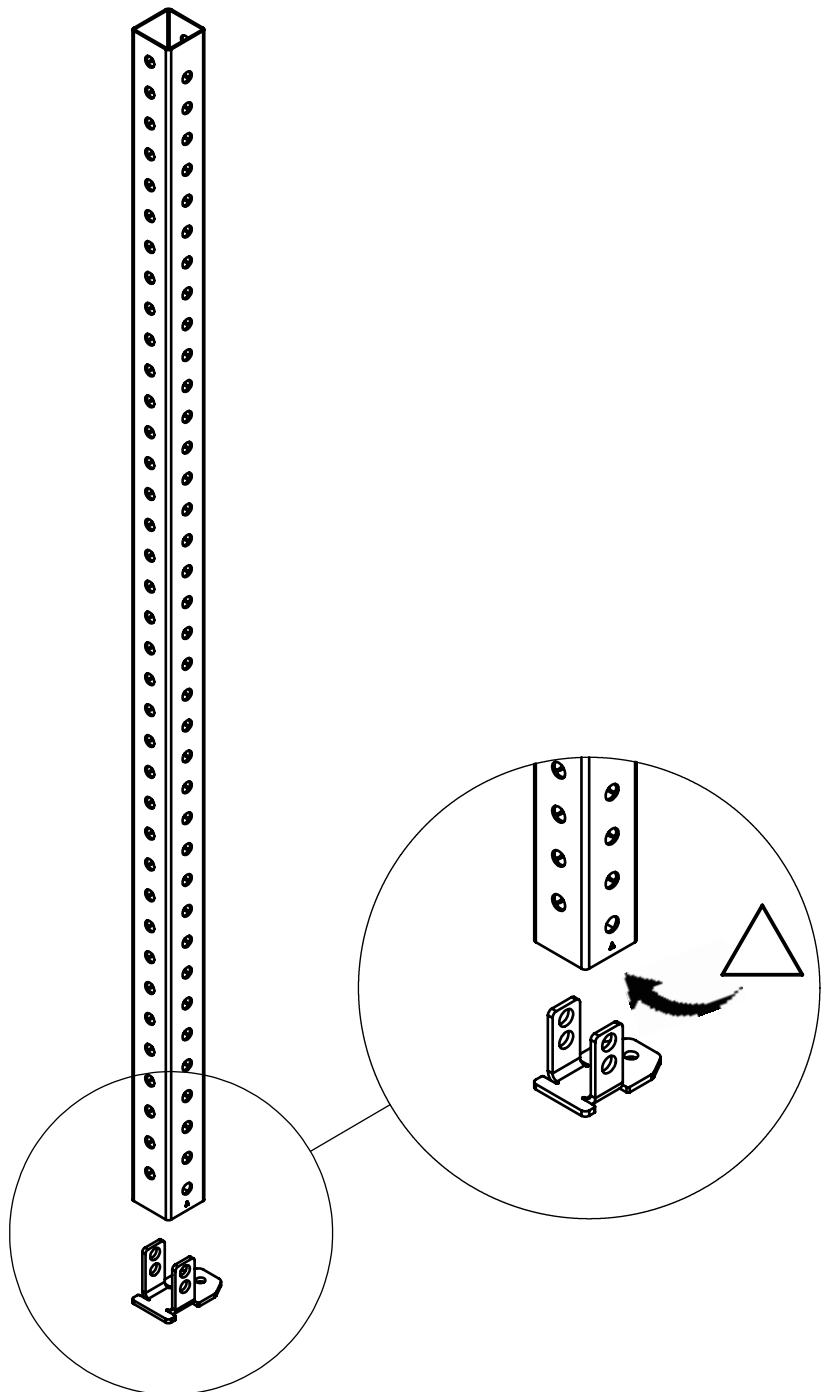

6a.

1x

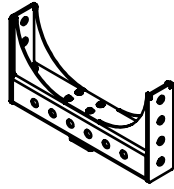

2001592

REMOVE COVER PLATES FROM FLOOR BEAMS!
SAVE ALL PARTS!

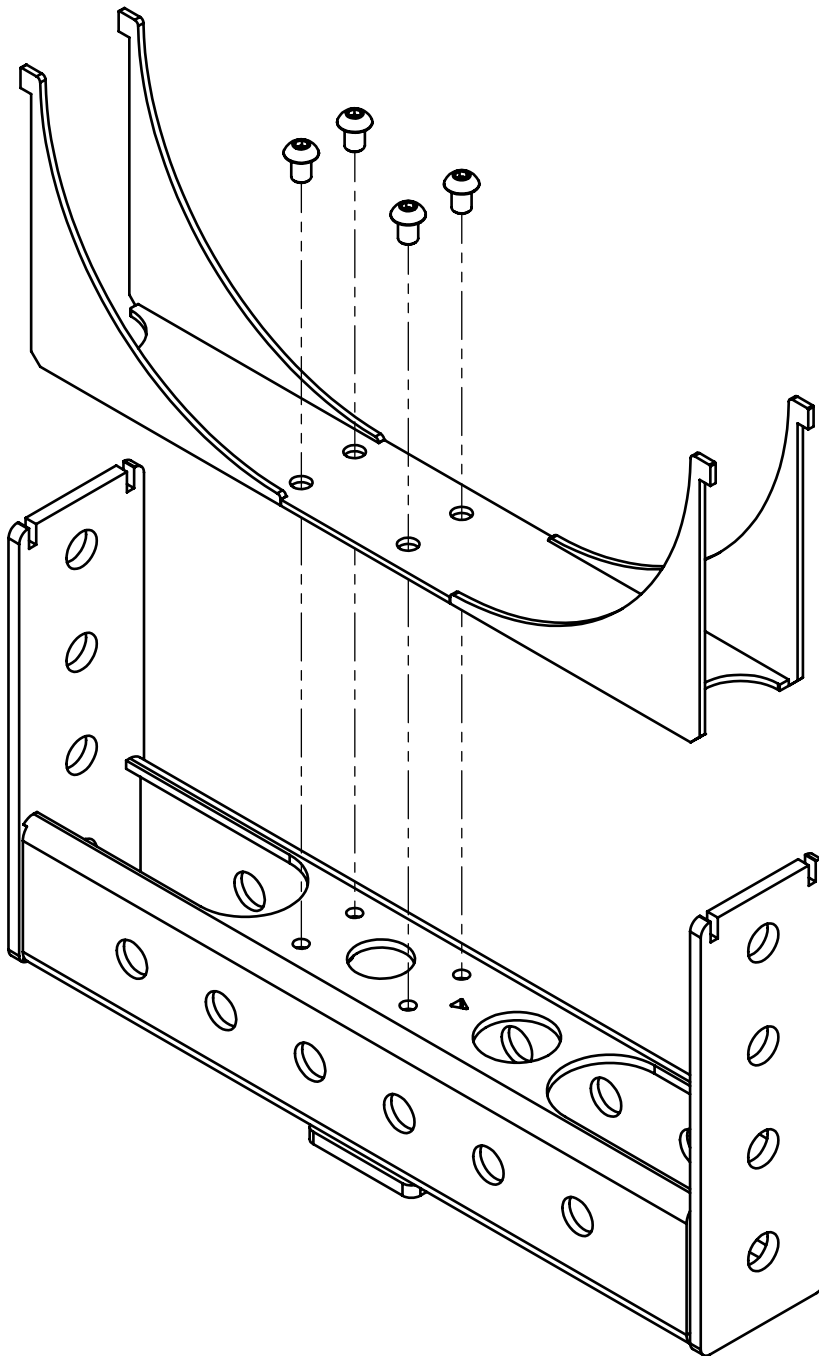

6b.

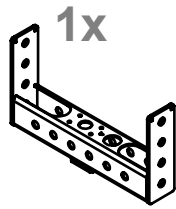

2001592

2x



M16x110

4x



2001421

2x



2001379

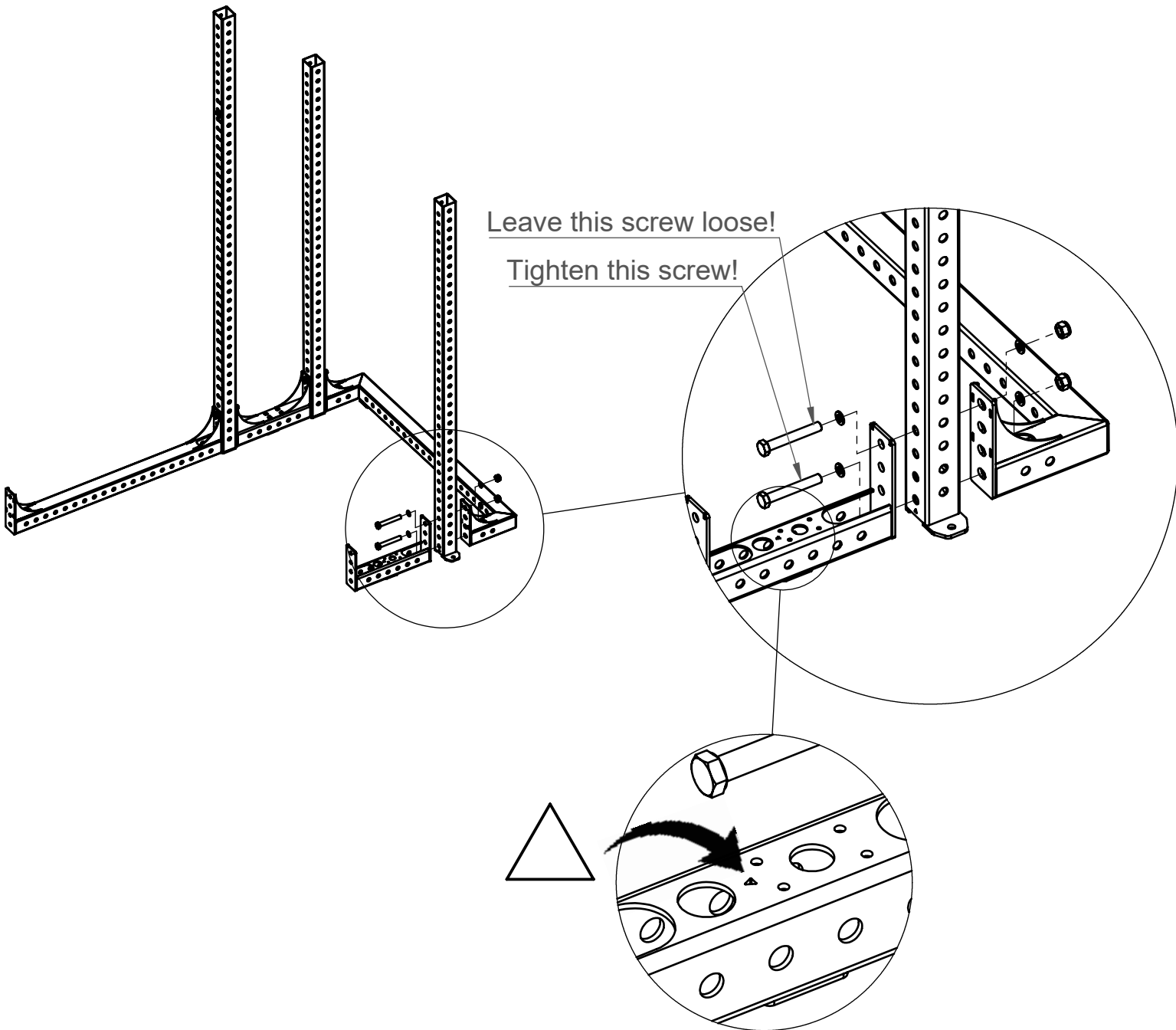

TRIANGULAR CUT OUT SHOULD POINT TOWARDS THE FRONT OF THE RACK!

7.

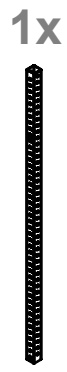

1x

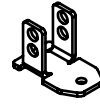

2001257 / 2001374 / 2001548 / 2001537

2001373

NOTE: USE THE TALLER UPRIGHT!

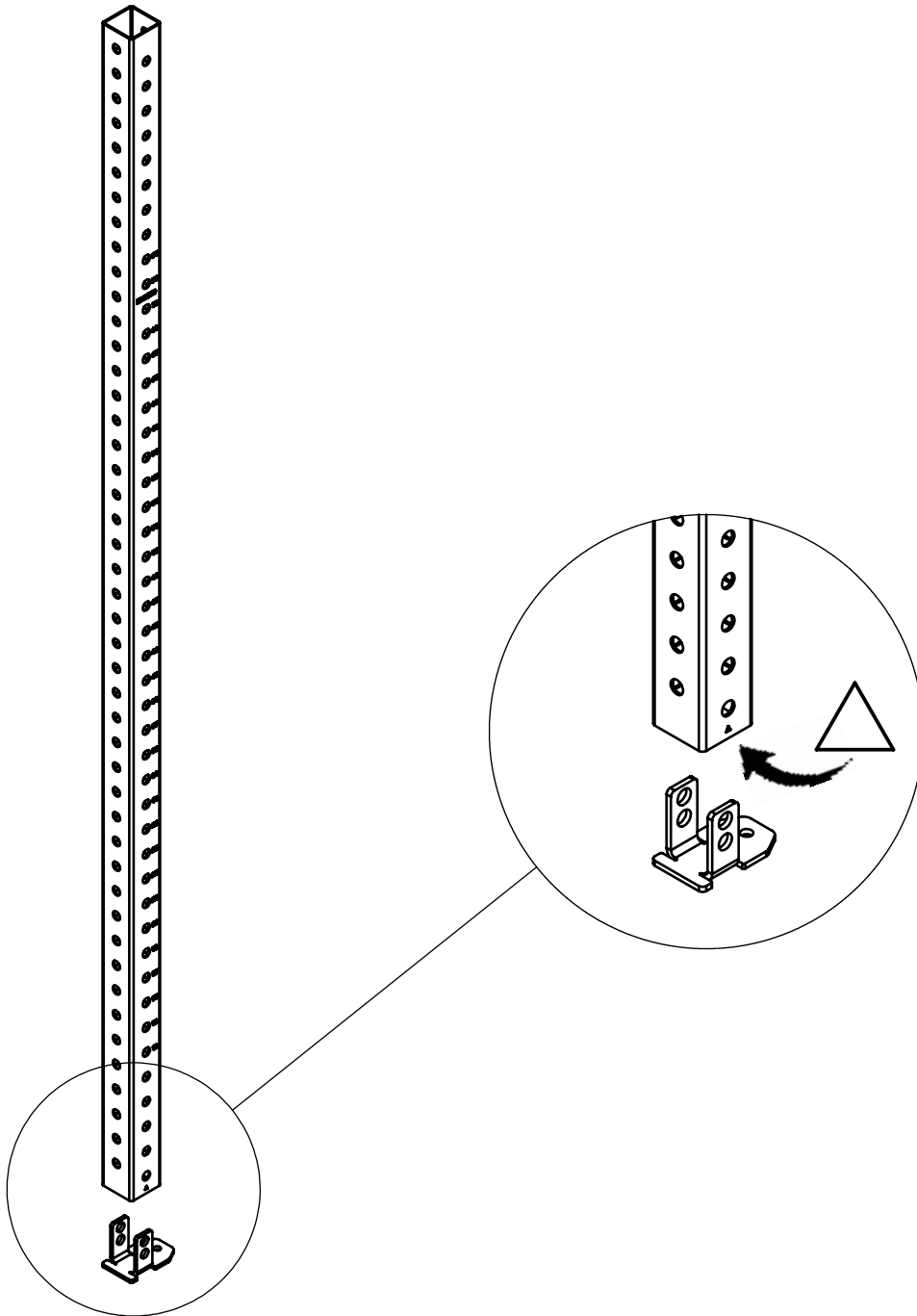

8a.

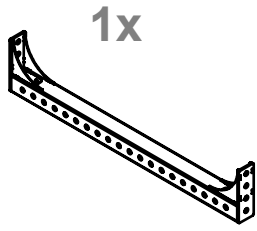

1x

2001375

2x

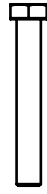

M16x110

4x



2001421

2x



2001379

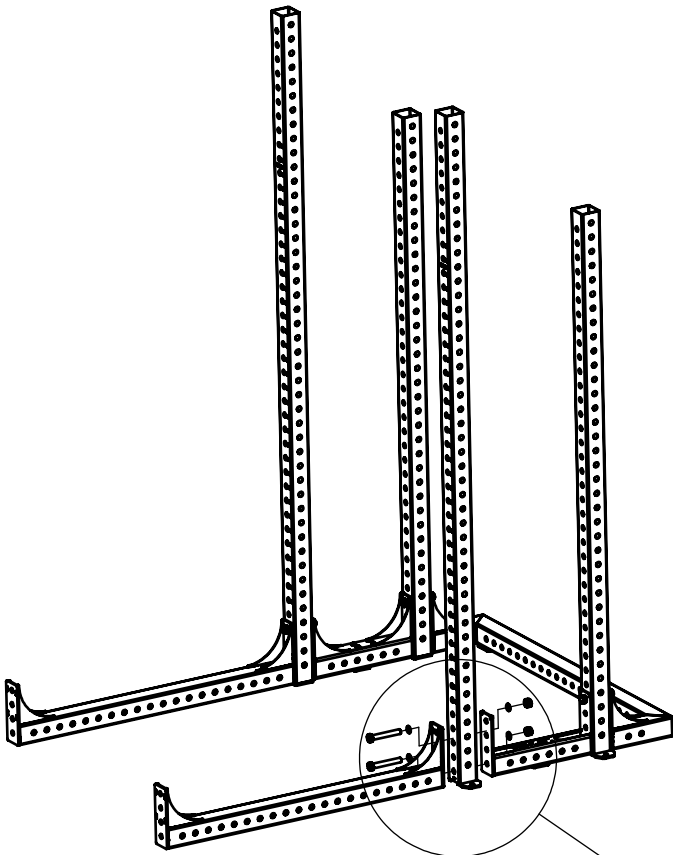

Leave this screw loose!

Tighten this screw!

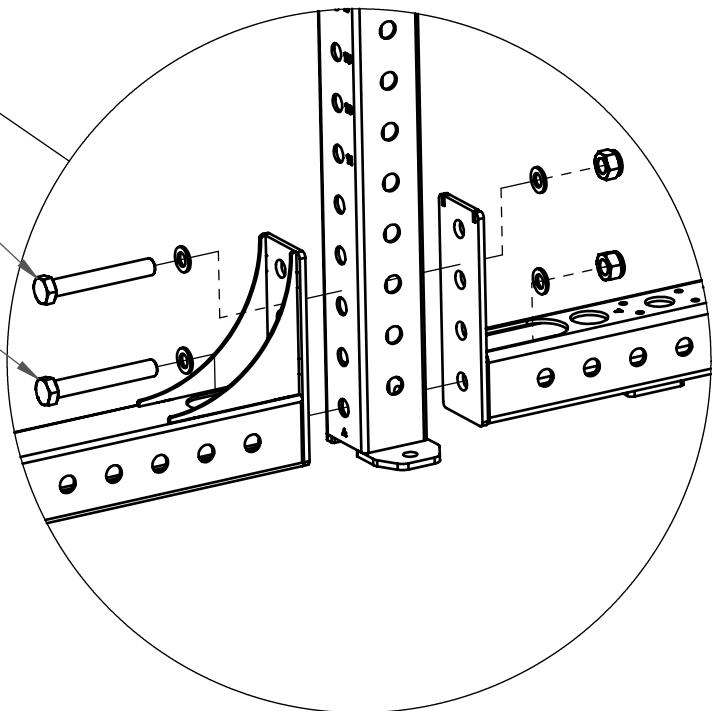

8b.

PUT BACK COVER PLATE ON FLOOR BEAM!
USE PARTS FROM STEP 6a!

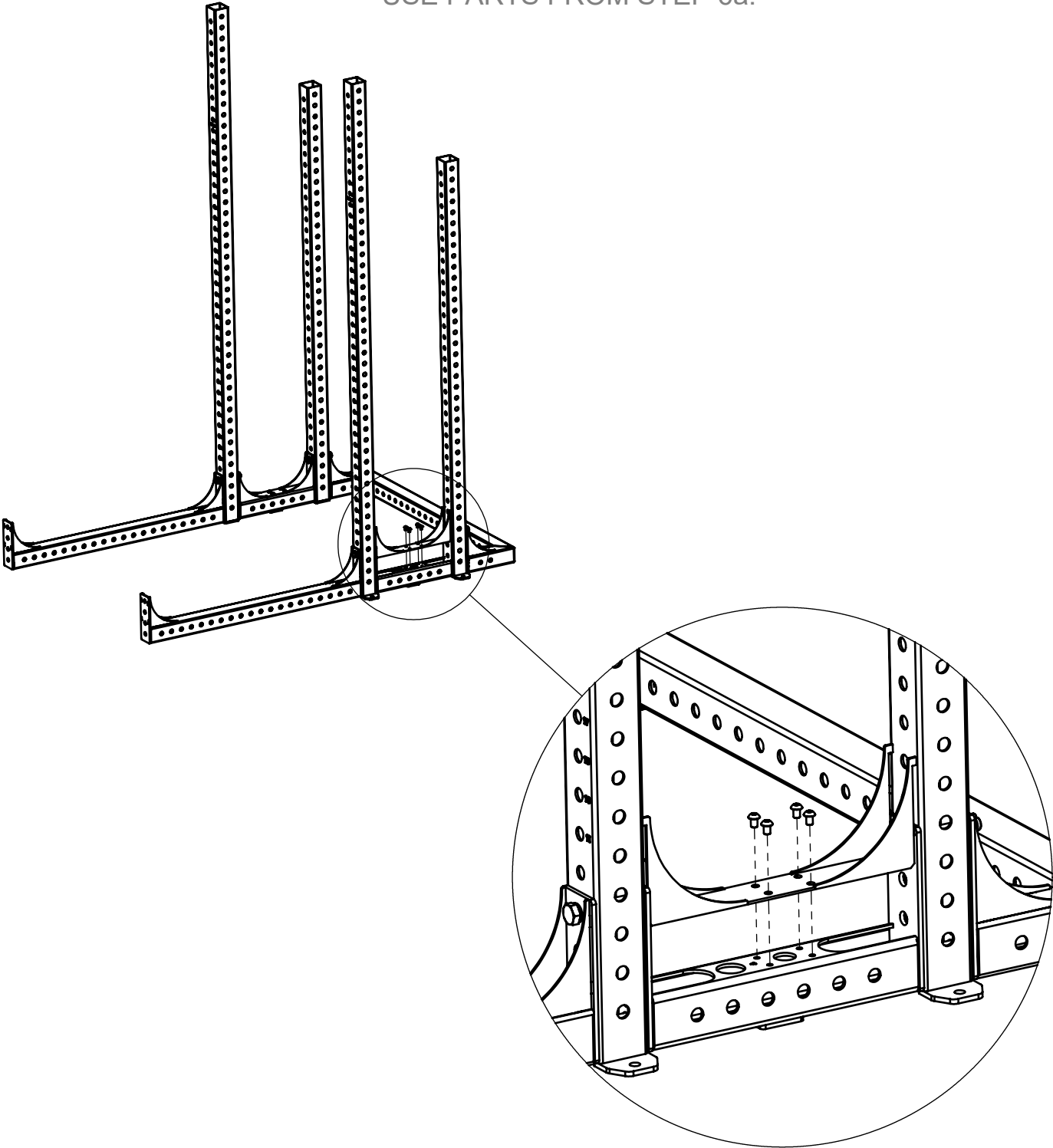

9.

2x



2x

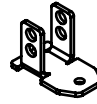

2001257 / 2001374 / 2001548 / 2001537

2001373

NOTE: USE THE TALLER UPRIGHTS!

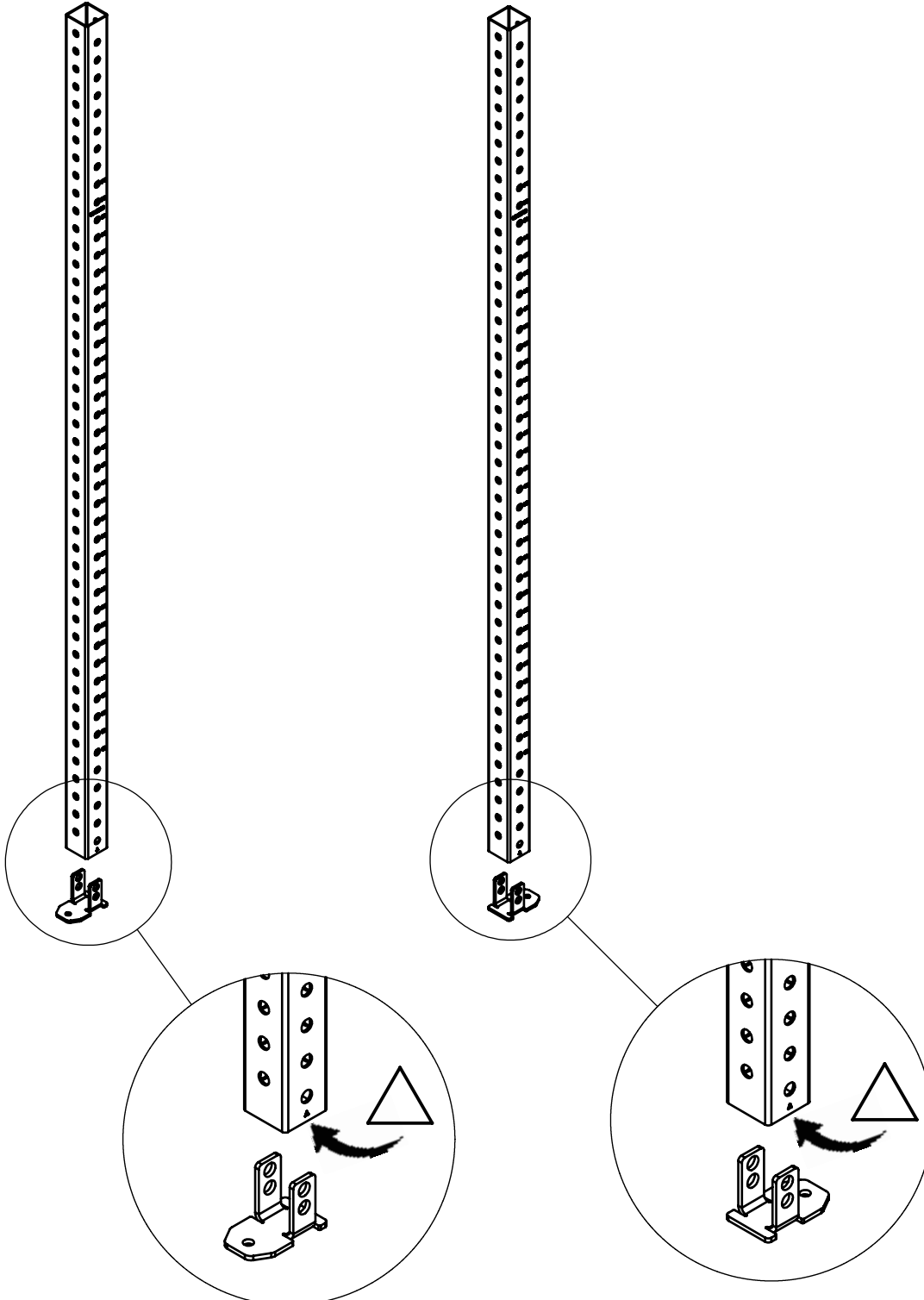

10.

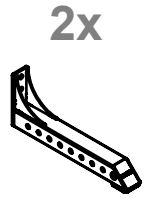

2001302

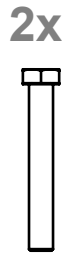

M16x110

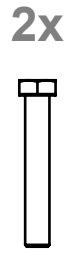

M16x100



2001421



2001379

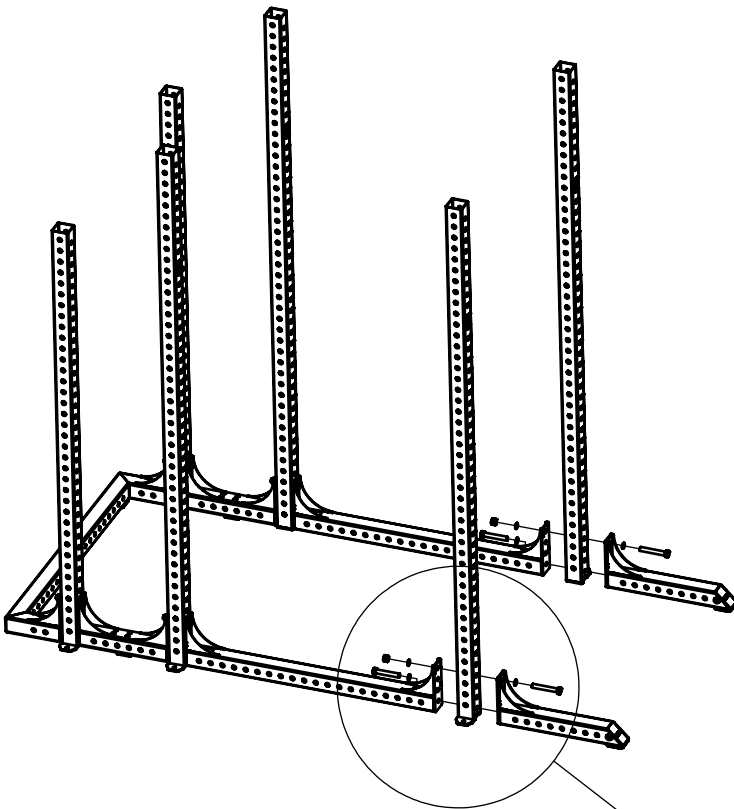

LOOSE SCREWS!

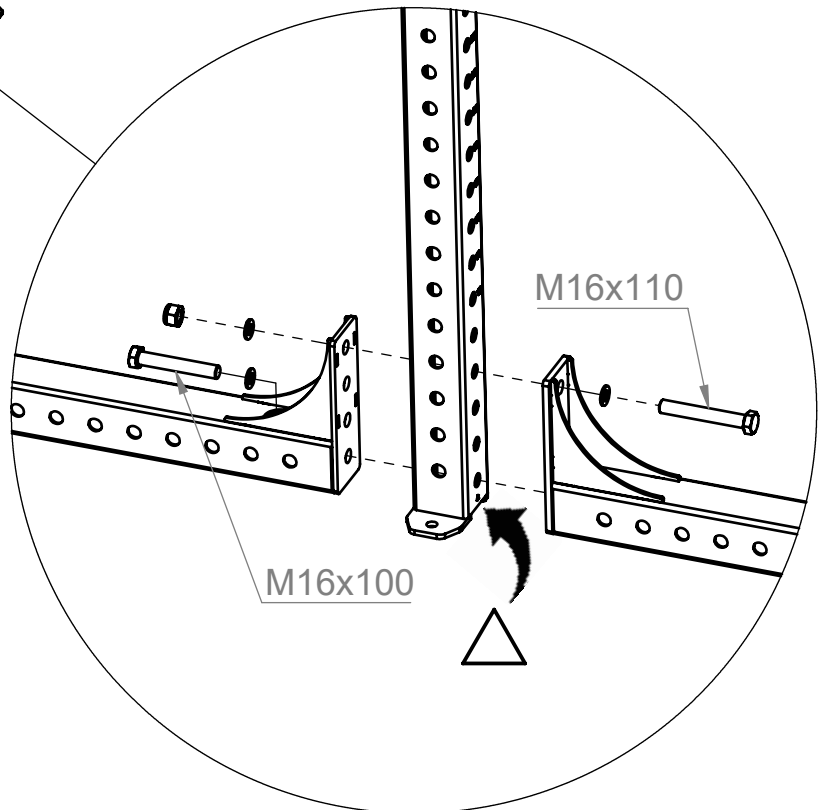

10b.

If purchased J-cups or Safety arms on sled, assemble them now.

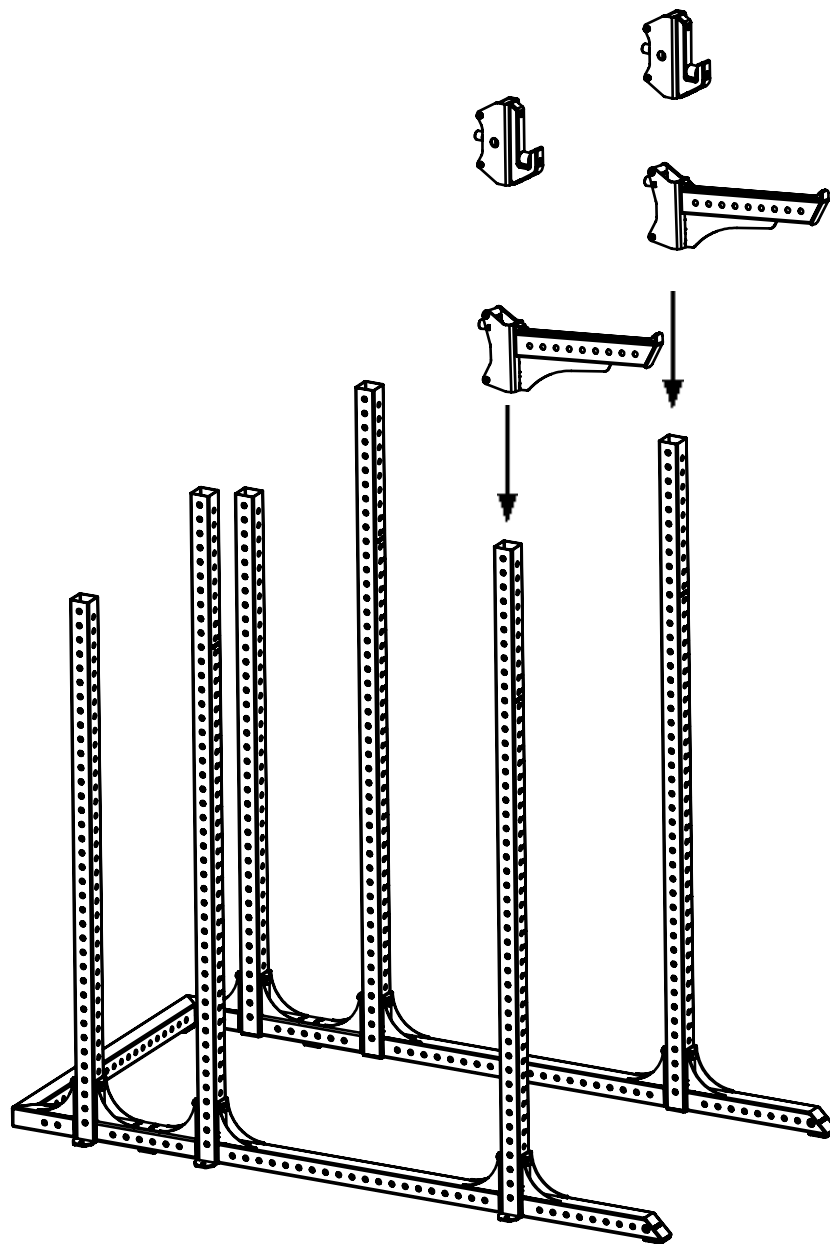

11a.

If purchased Eleiko Pretera Muscle Up Bar (Rack only), assemble it now. See manual 3085623-M.

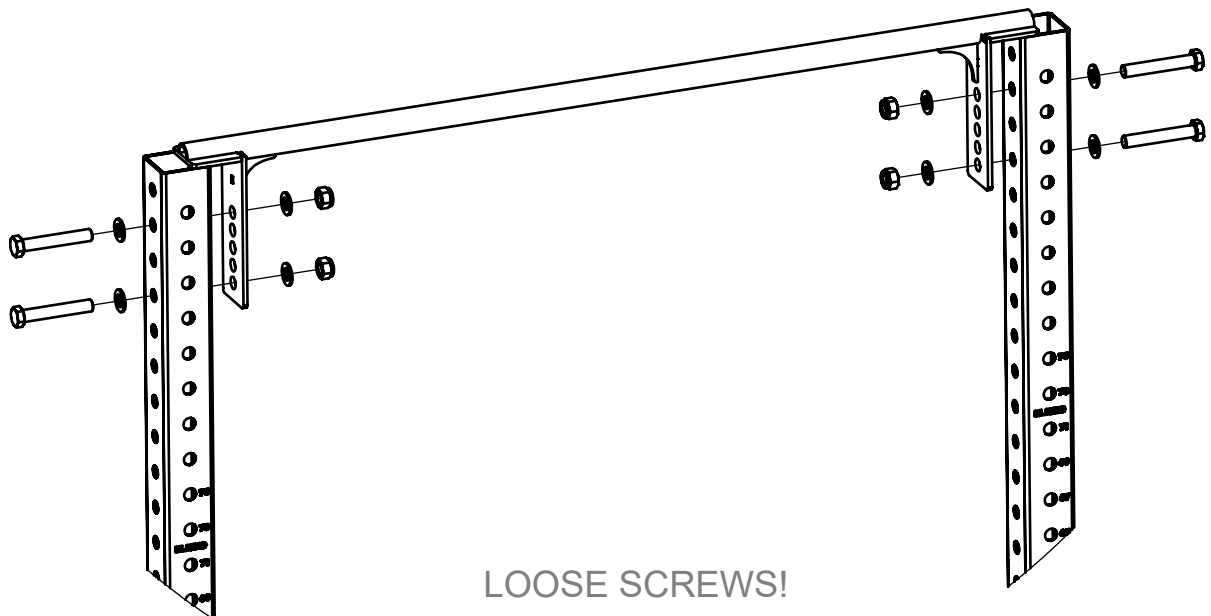
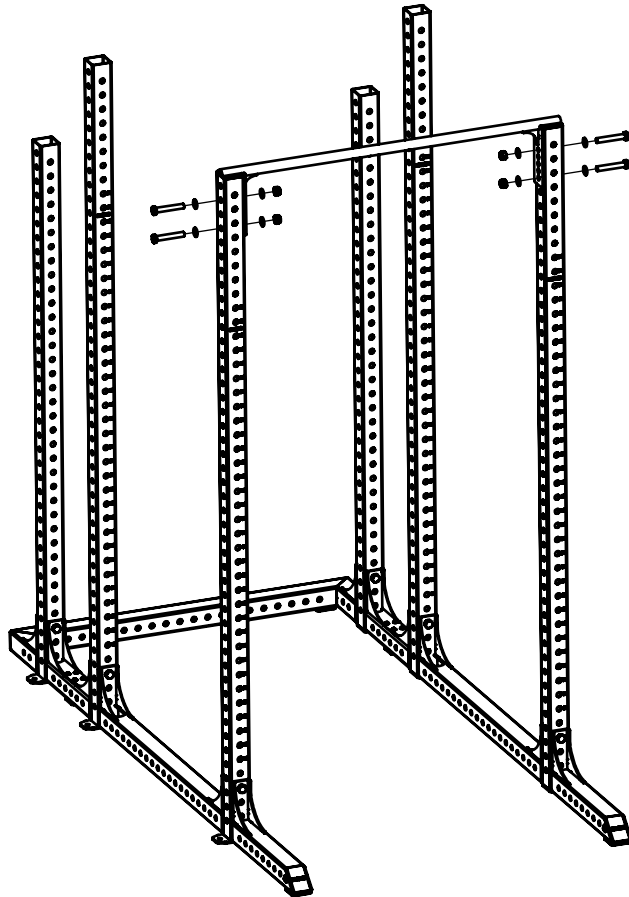

LOOSE SCREWS!

11b.

2x

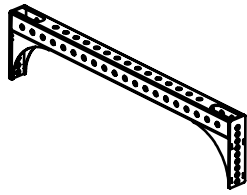

2001294

8x

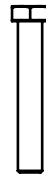

M16x100

16x



2001421

8x



2001379

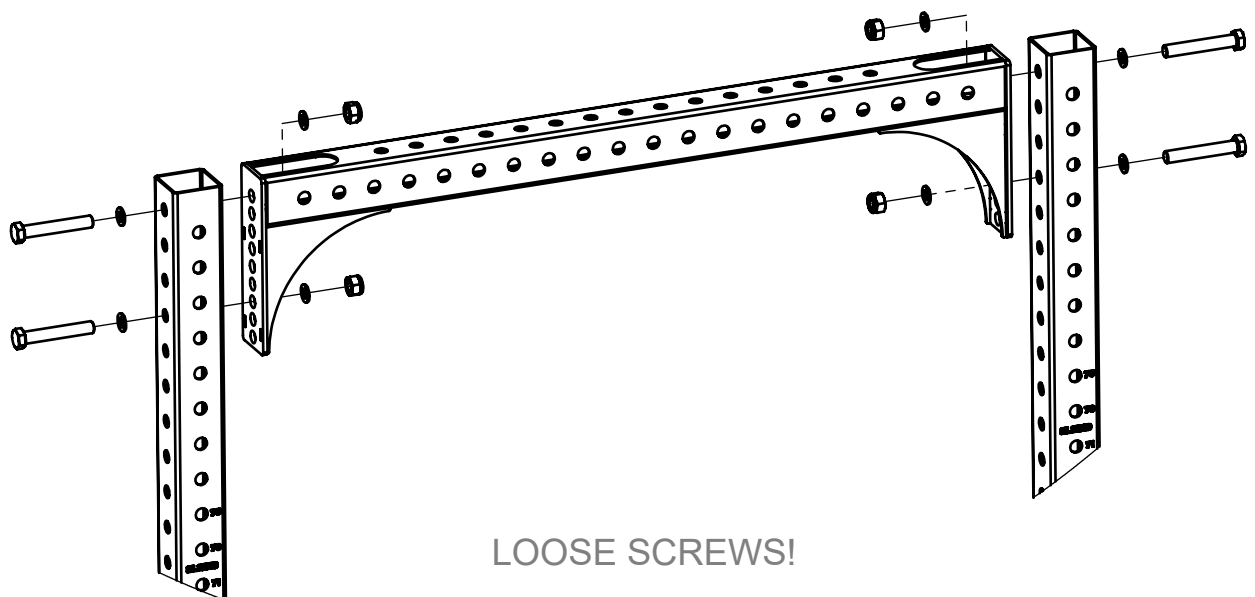
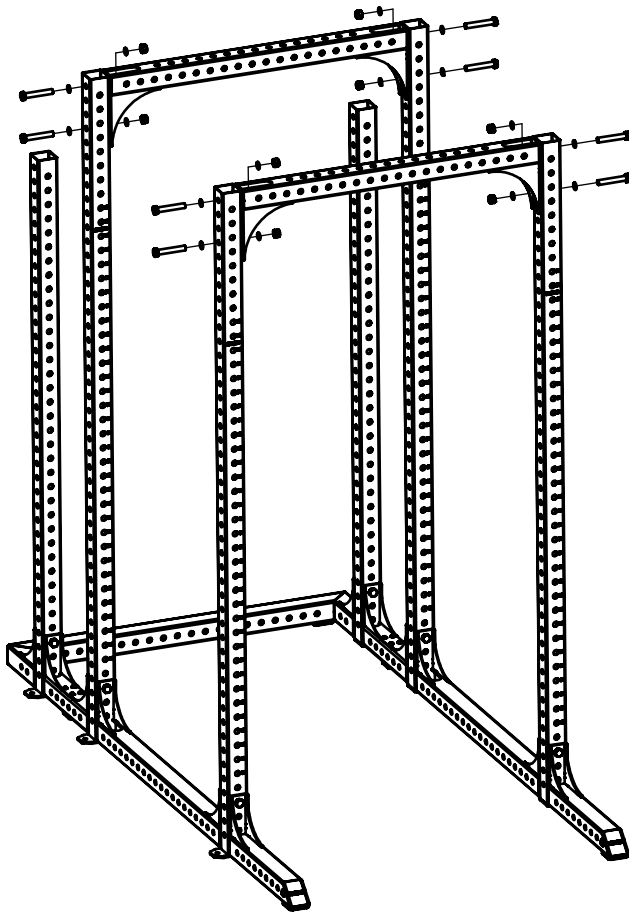

LOOSE SCREWS!

12.

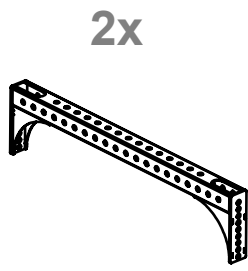

2x

2001294

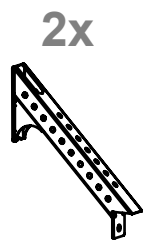

2x

2001299

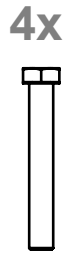

4x

M16x110

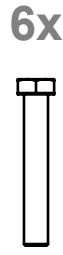

6x

M16x100

20x



2001421

10x



2001379

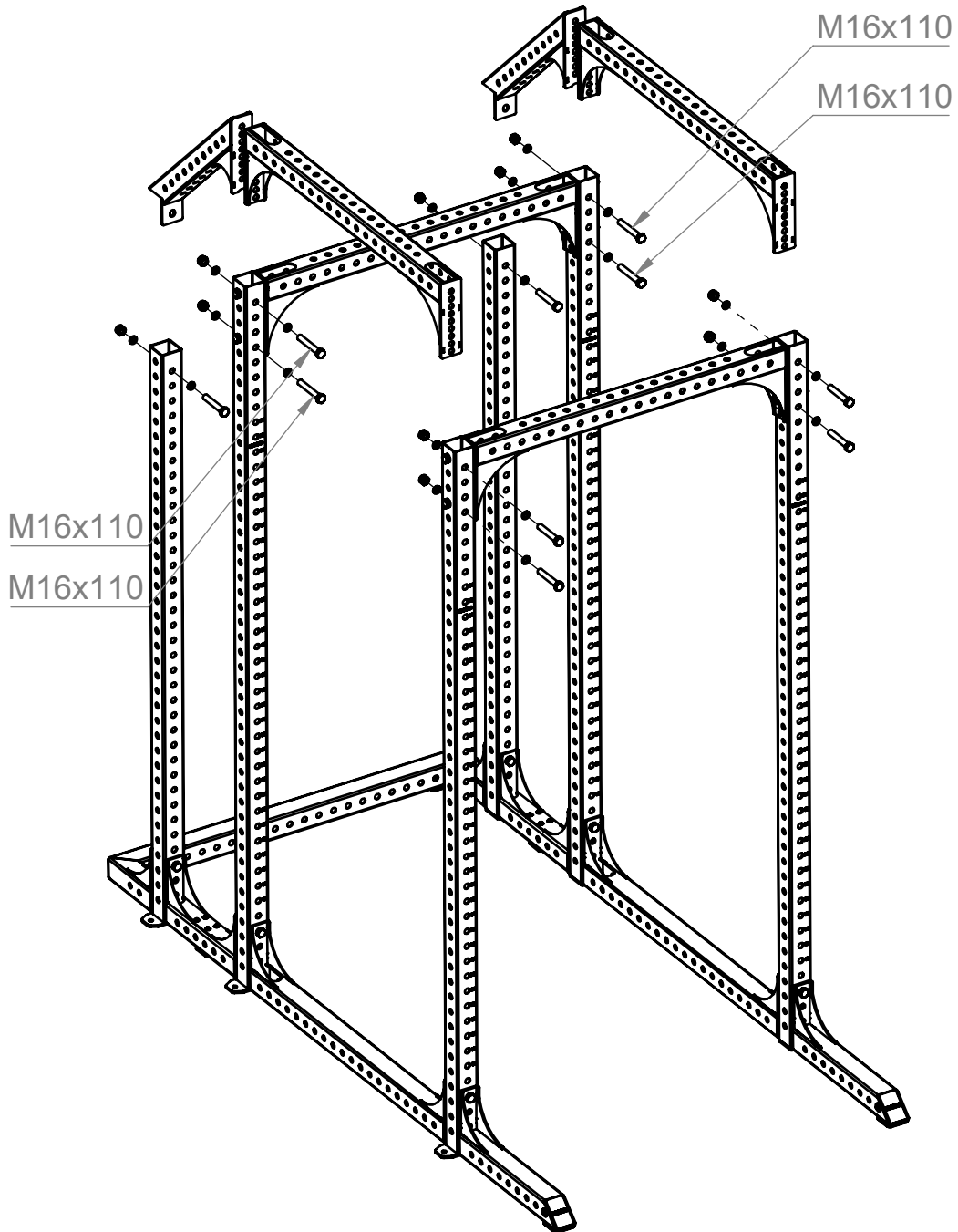

LOOSE SCREWS!

13.

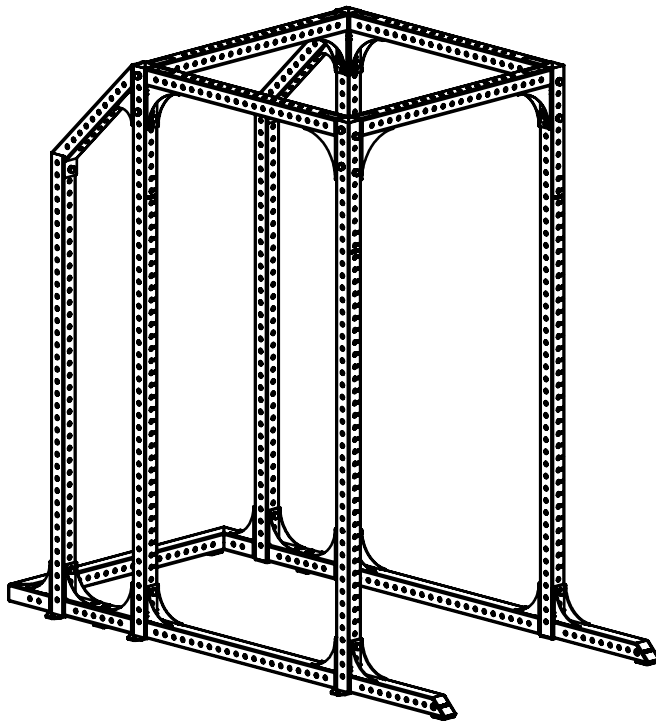

TIGHTEN ALL SCREWS!
START WITH THE ONES AT THE TOP!

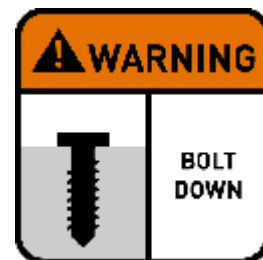
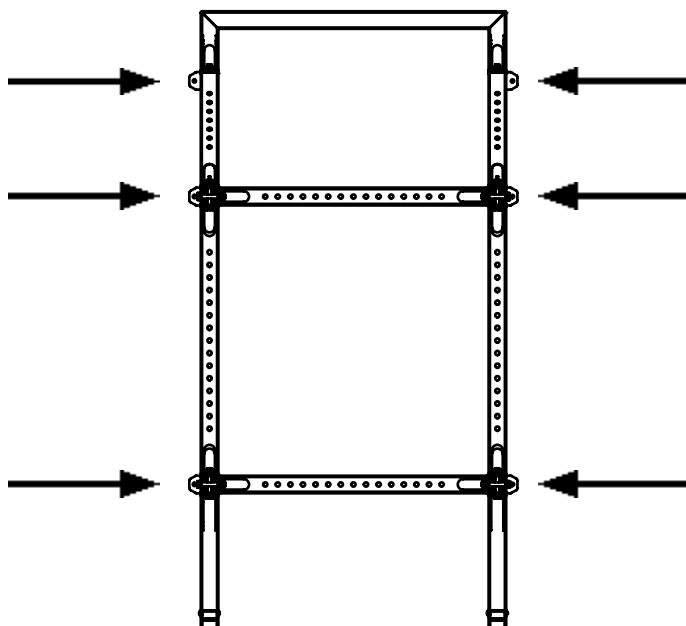

USER GUIDE

PURPOSE

Multi-purpose rack for squats, presses and pull ups. Possibility to add attachments for specific exercises.

GENERAL INSTRUCTIONS FOR USE

1. Add attachment for the selected exercise.
2. Follow instructions for that specific attachment.

PRODUCT SPECIFICATION

Max training weight 500 kg / 1102 lbs

Product weight:

3085635 163 kg / 359 lbs

3085467 & 3085550 171 kg / 377 lbs

3085723 178 kg / 392 lbs

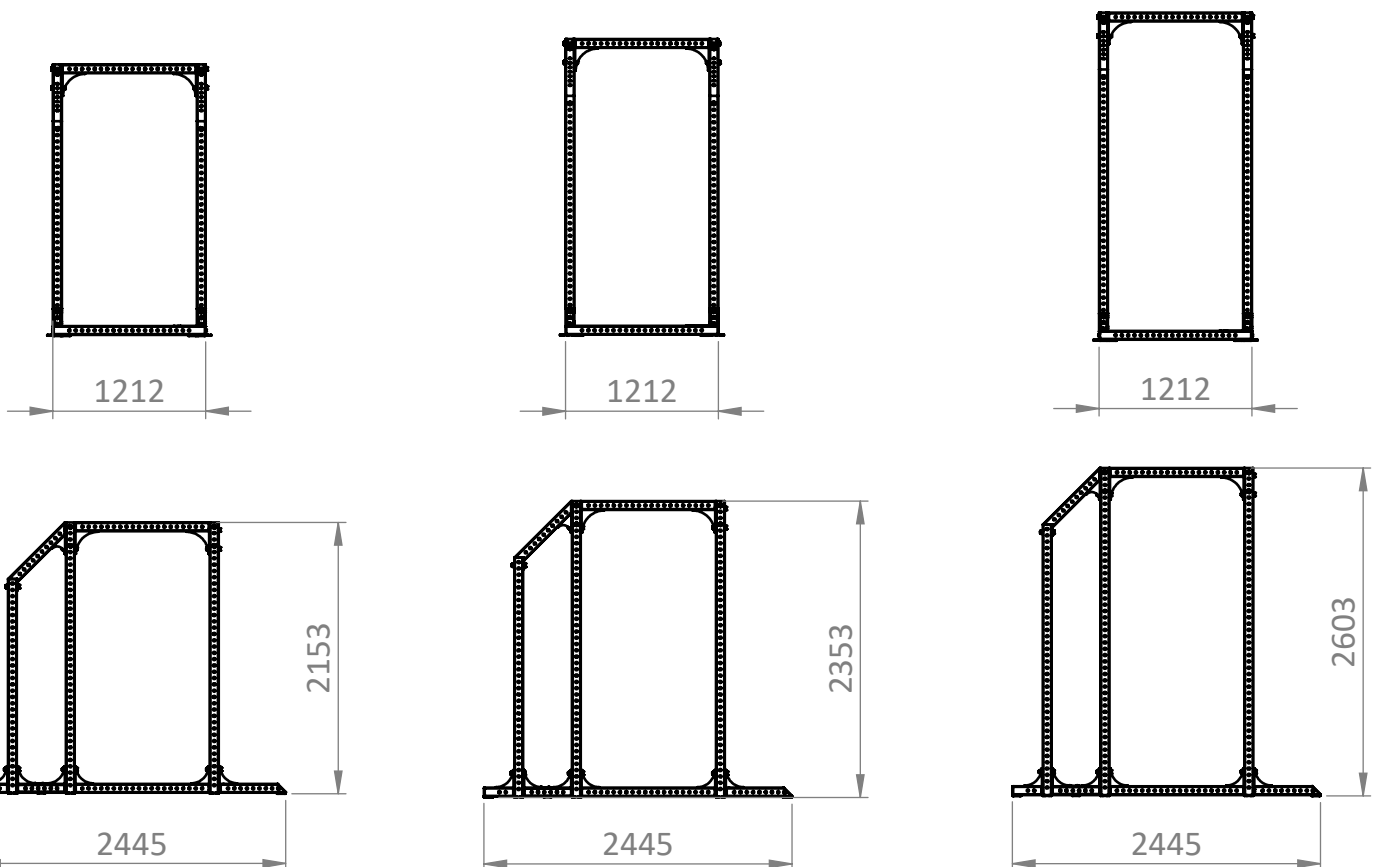

CARE AND MAINTENANCE

PREVENTIVE MAINTENANCE AND INSPECTIONS

NOTE: The safety level of the equipment can only be maintained if it is examined regularly for damage and wear.

Regularly:

- Clean surfaces on the frames and tubes from dust and dirt.
- Check that all bolts between parts, walls and floors are properly tightened, according to recommendations.
- Check equipment for sharp edges. Replace parts with sharp edges.

See also www.eleiko.com.

SPARE PARTS AND SERVICE

Contact Eleiko for spare parts and service:

Eleiko Group AB | Klastorpsvägen 18 | SE-302 62 HALMSTAD | Sweden

E-mail: info@eleiko.com | Phone: +46 35 17 70 70

WARRANTY

All products manufactured by ELEIKO are warranted to the original purchaser to be free from defects in workmanship and / or materials under normal use or service as follows:

- 10 years on structural frame welds (NOT on moving parts)

Normal wear and tear do not fall under the 10-year warranty.

ELEIKO

Eleiko Group AB | Klastorpsvägen 18 | SE-302 62 HALMSTAD | Sweden
E-mail: info@eleiko.com | Phone: +46 35 17 70 70

www.eleiko.com